

**ca  
ma  
le  
da  
da**

un'idea di  
Mario Bellini

dieci, cento  
modi di vivere

**B&B**  
ITALIA

# Index

Camaleonda	p. 1	Gli Scacchi	p. 51
Mario Bellini biography	p. 2	Technical drawings	p. 61
The history	p. 3	Camaleonda value proposition	p. 62
Inspirations and textile trends 2021/2022	p. 7	Delivery terms	p. 63
The present	p. 20	Marketing tools	p. 64
Compositions	p. 22	Marketing and communication plan	p. 65
The future	p. 40		
Abaco	p. 44		
Endless compositions	p. 45		

# Camaleonda

design Mario Bellini

The system designed in 1970,  
makes its comeback 50 years later,  
speaking a contemporary language,  
between structural solutions and  
sustainable choices.

Il sistema disegnato nel 1970, ritorna dopo 50 anni  
e parla un linguaggio contemporaneo,  
tra nuove soluzioni strutturali e scelte sostenibili.

# Mario Bellini

Mario Bellini is an architect and designer internationally renowned.

He received the Golden Compass Award eight times and 25 of his works are in the permanent design collection of the New York MoMA, which dedicated to him a personal retrospective in 1987).

He has designed countless art, design and architecture exhibitions over the years, both in Italy and abroad: among the latest those at Palazzo Reale with Giotto's masterpieces (2016) and - at the Milanese Museo del '900 - the one dedicated to Margherita Sarfatti (2018-2019). In 2015 the Milan Triennale awarded him the Gold Medal for his career in architecture. Since 1991 he is Royal Honorary Designer of RDI.

Since the 1980's Mario Bellini dedicated himself almost entirely to architecture. Projects currently underway are the New Polytechnic School of Genoa (2006-2020), a vast hotel and residential development on Virgin Gorda Island in the British Virgin Island (2018-2020). He also has various projects at the design stage.

Mario Bellini è un architetto e designer noto in tutto il mondo.

Ha ricevuto il Premio Compasso d'Oro otto volte e 25 delle sue opere sono nella collezione permanente del MoMA di New York, che gli ha dedicato una retrospettiva nel 1987.

Ha progettato numerose mostre d'arte e di architettura sia in Italia, sia all'estero, tra le ultime quelle a Palazzo Reale con i capolavori di Giotto (2016) e al Museo del '900 dedicata a Margherita Sarfatti (2018-2019). Nel 2015 la Triennale di Milano gli ha assegnato la Medaglia d'oro alla carriera per l'Architettura.

Dal 1980, si dedica prevalentemente all'architettura. I progetti attualmente in corso sono la Nuova Scuola Politecnica di Genova (2006-2020), una vasta struttura alberghiera e residenziale a Virgin Gorda Island nelle British Virgin islands (2018-2020) e la nuova sede della RAI a Milano (2018-2020).

Diversi anche i progetti in fase di studio.

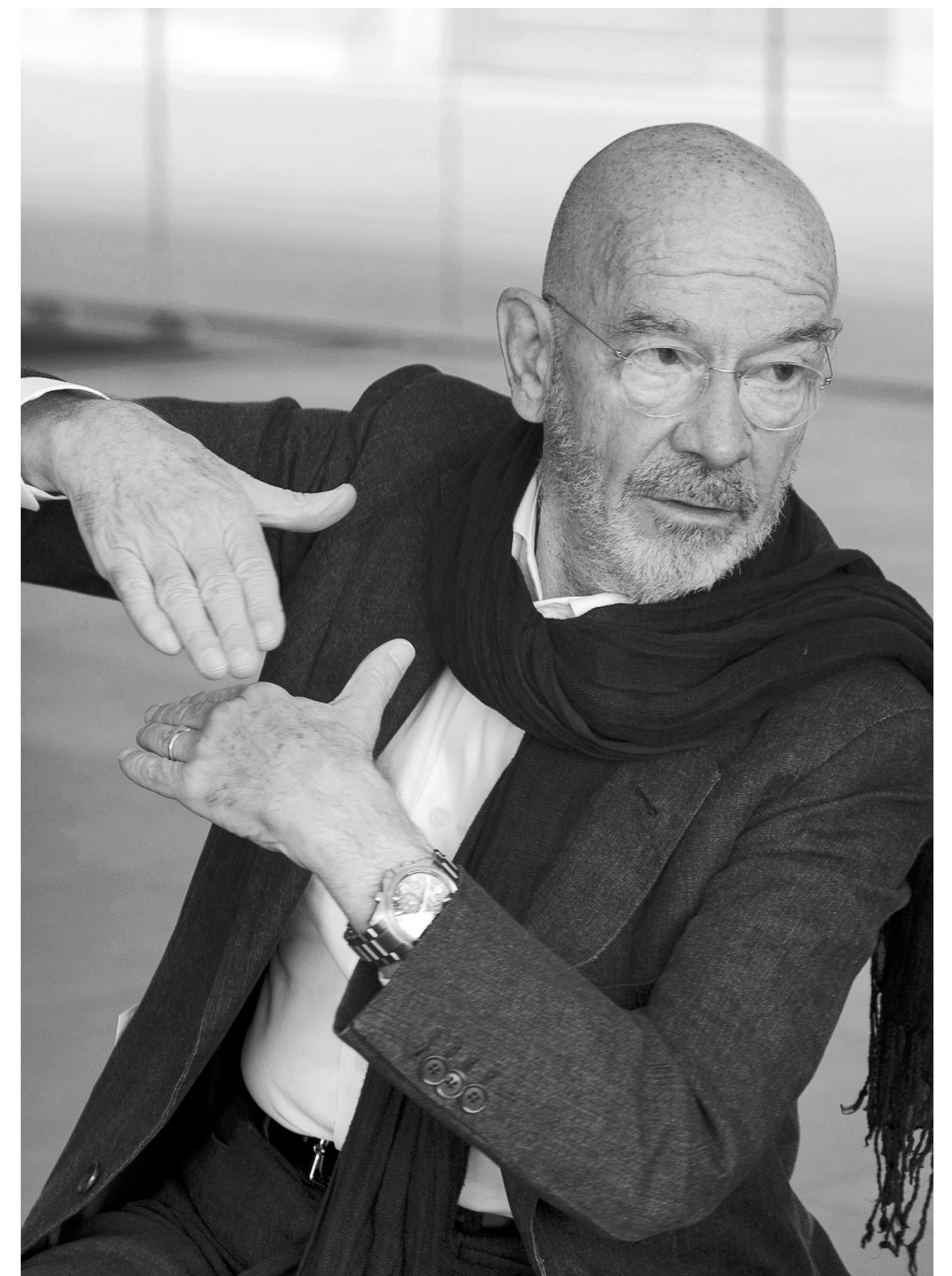

# The history:

## 50 years that have not gone by

Presented to the public in 1970, Camaleonda has passed through 5 decades of design history as a true icon. Designed by Mario Bellini, this modular sofa has defined the aesthetics of an entire era of interior design, thanks to its great success both in terms of the public and critics. It is constantly featured in most international design museums and in the film-sets that have defined the collective imagination. An object that is loved by design aficionados, antique dealers and interior decorators alike is finally back in production after a careful design process that involved the close collaboration between the B&B Italia's Research & Development Centre and Mario Bellini.

Mario Bellini's work is characterized by bringing together design and architecture

and Camaleonda testifies to his unique ability to move confidently between diverse design languages, between macro and micro, geometry and curves, artificial and natural materials. As Bellini himself says, Camaleonda was created to fill a void: "At the beginning of the 1970s, upholstered furniture for the home had stagnated into the tired traditional stereotypes and radical-provocative elitist forays into the future that, although stimulating, rarely challenged the relationship between the evolution of new patterns of behaviour in the home and the types of furniture available on the market at the time."

With Camaleonda we find ourselves in the presence of a sofa intended as an architectural element, capable of

transforming the landscape of the interior space that it inhabits. A landscape that is neither immobile nor permanent, as its chameleon-like nature involves change and transformation. A promise that is clear from the name itself, as Bellini recalls: "Camaleonda is a name that I invented in 1970 by mixing two words: the first is the name of an extraordinary animal, the chameleon (camaleonte in Italian), that can adapt to the environment around it and the word 'onda', wave, that indicates the curve of the sea and the desert. Both these words describe the shape and function of this sofa."

Camaleonda continues to live on thanks to an identity that has become an evergreen iconic vintage, current for each generation precisely because of its timeless qualities.

# La storia:

## 50 anni che non sono passati

Presentato al pubblico nel 1970, Camaleonda ha attraversato 5 decenni di storia del design da assoluto protagonista.

Disegnato da Mario Bellini, questo divano modulare ha definito l'estetica dell'interior design di un'epoca grazie al suo grande successo di pubblico e critica.

La sua presenza è una costante nei maggiori musei di design internazionali e sui set di film che hanno definito l'immaginario collettivo. Un oggetto amato da appassionati di design, antiquari e interior decorator, finalmente entra di nuovo in produzione, dopo un attento lavoro di progettazione che ha visto lavorare a stretto contatto il Centro Ricerche & Sviluppo di B&B Italia e Mario Bellini.

Il lavoro di Mario Bellini si caratterizza per la sintesi tra design e architettura e con Camaleonda conferma una capacità unica

di muoversi con dimestichezza tra linguaggi di progettazione differenti, tra macro e micro, tra geometria e imbottiture, materiali artificiali e naturali.

Come racconta Bellini stesso, Camaleonda nasce per colmare un vuoto: "Alla soglia degli anni '70 gli arredi domestici imbottiti ancora stagnavano per lo più tra stanche varianti delle tipologie storiche ed elitarie fughe in avanti radical-provocatorie, che – sebbene stimolanti – risultavano difficilmente capaci di rimettere in discussione il rapporto tra l'evoluzione dei nuovi comportamenti nello spazio domestico e le tipologie di arredi allora disponibili sul mercato."

Con Camaleonda ci troviamo al cospetto di un divano concepito quasi come elemento architettonico, capace di trasformare lo skyline degli interni che lo ospitano.

Un paesaggio che non si rivela immobile e permanente, perché la sua natura camaleontica prevede il cambiamento e la trasformazione. Una promessa che parte dal nome stesso, come ricorda Bellini: "Camaleonda è un neologismo che ho inventato io nel 1970 incrociando due parole: il nome di quell'animale straordinario che è il camaleonte capace di adattarsi all'ambiente in cui si trova e la parola onda che indica le curve del mare e del deserto. Entrambe queste parole descrivono la forma e la funzione di questa seduta."

Camaleonda continua a vivere attraverso un'identità che diventa un vintage perenne, un attuale per ogni generazione proprio per le sue qualità atemporali.

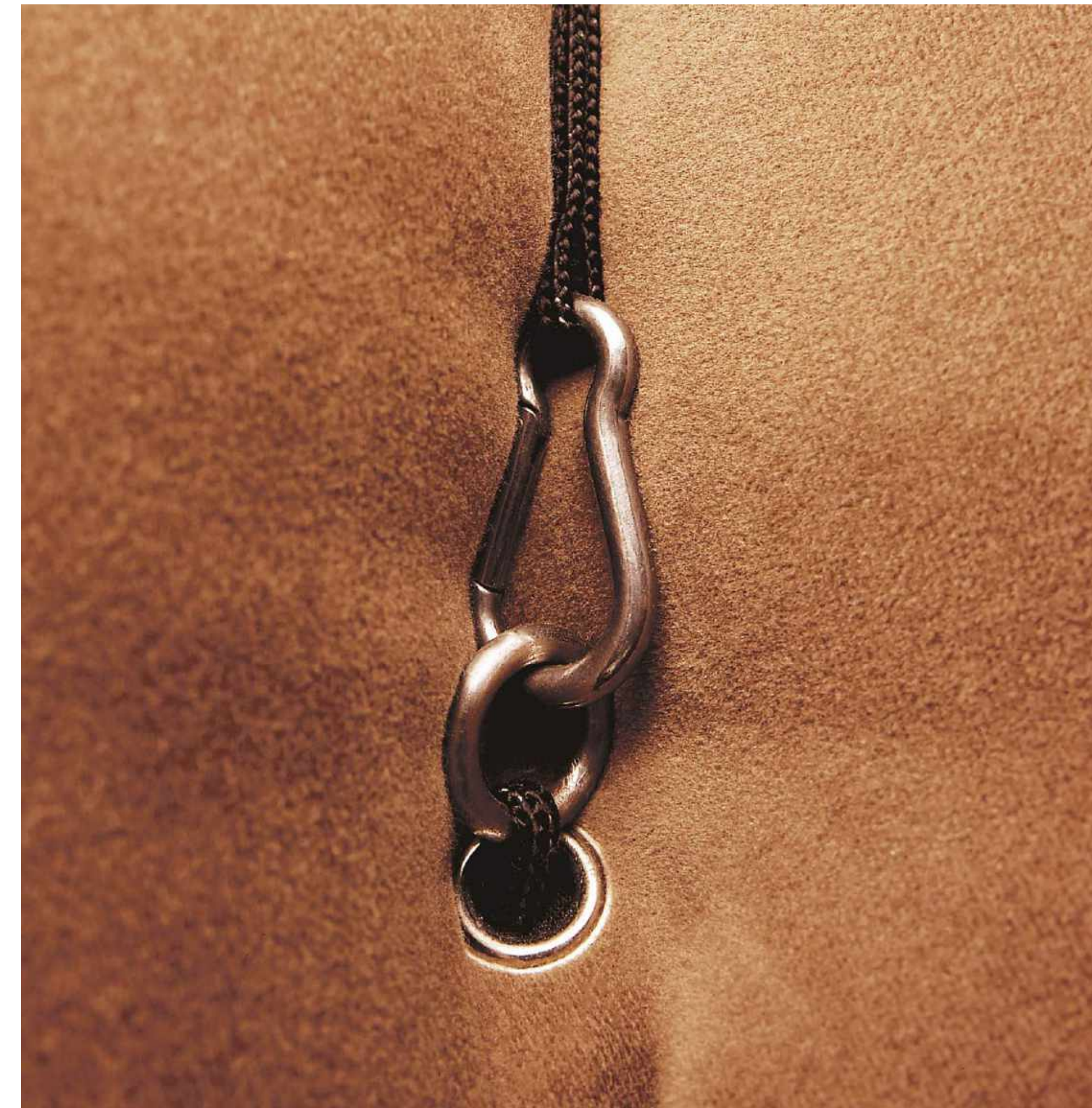

Camaleonda 1972





# Inspirations and textile trends 2021/2022

**Uncertainty has become the new normal and consumers are searching for textures and colours that brings comfort, joy and optimism. B&B Italia has sourced inspirations from its past and from the future to dress Camaleonda for its big come back.**

**Velvets and chenille aspects - which strongly characterized the Camaleonda at its birth in 1970 - are our source of inspiration for this 2020 relaunch.**

**More than ever it is time for sustainable solutions and for this reason Enia, the new corduroy chenille fabric, is made from recycled PET.**

**B&B Italia is presenting Camaleonda in 5 key colours, considering both professional colour trend reports for 2021/22 and the actual need**

**for safe (olive green, abyss blue, ivory white) and for mood boosting choices (curry orange, bougainvillea pink).**

**The following textile and colour inspirations are the result of all these aspects.**

**They should inspire choices without limiting them and be a suggestion for the relaunch of the Camaleonda.**

L'incertezza è diventata la nostra nuova normalità e i consumatori sono alla ricerca di trame e colori che offrano comfort, gioia e ottimismo. B&B Italia ha tratto ispirazione dal suo passato e dal futuro per vestire Camaleonda per il suo grande ritorno: velluti e ciniglie - che hanno caratterizzato fortemente Camaleonda alla sua nascita nel

1970 - sono la fonte d'ispirazione per questo rilancio 2020. Oggi più che mai necessitiamo di soluzioni sostenibili e per questo motivo il nuovo tessuto Enia, una ciniglia a coste, è realizzato in PET riciclato.

B&B Italia ha identificato 5 colori chiave, basandosi su previsioni di trend tessili per il 2021/22 ma anche sulla necessità attuale di colori che rassicurino (olive green, abyss blue, ivory white) e siano portatori di buon umore (mandarin orange, bougainvillea pink).

Le seguenti ispirazioni tessili e cromatiche sono il risultato di tutti questi aspetti. Mirano ad ispirare le scelte senza limitarle, regalando dei suggerimenti per il rilancio del Camaleonda.



Ivory white



Bougainvillea pink



Olive green



Abyss blue



Curry orange

# Enia - new B&B Italia fabric



Enia 103



Enia 777



Enia 400



Enia 800



Enia 571

**B&B Italia is presenting Camaleonda in 5 key colours, considering both professional colour trend reports for 2021/22 and the actual need for safe (olive green, abyss blue, ivory white) and for mood boosting choices (curry orange, bougainvillea pink).**

B&B Italia ha identificato 5 colori chiave, basandosi su previsioni di trend tessili per il 2021/22 ma anche sulla necessità attuale di colori che rassicurino (olive green, abyss blue, ivory white) e siano portatori di buon umore (mandarin orange, bougainvillea pink).

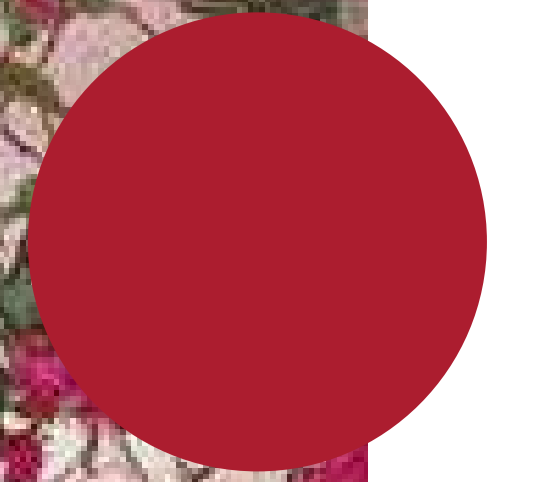
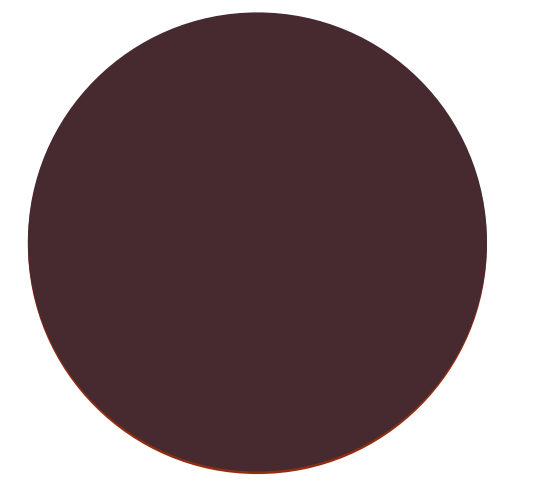
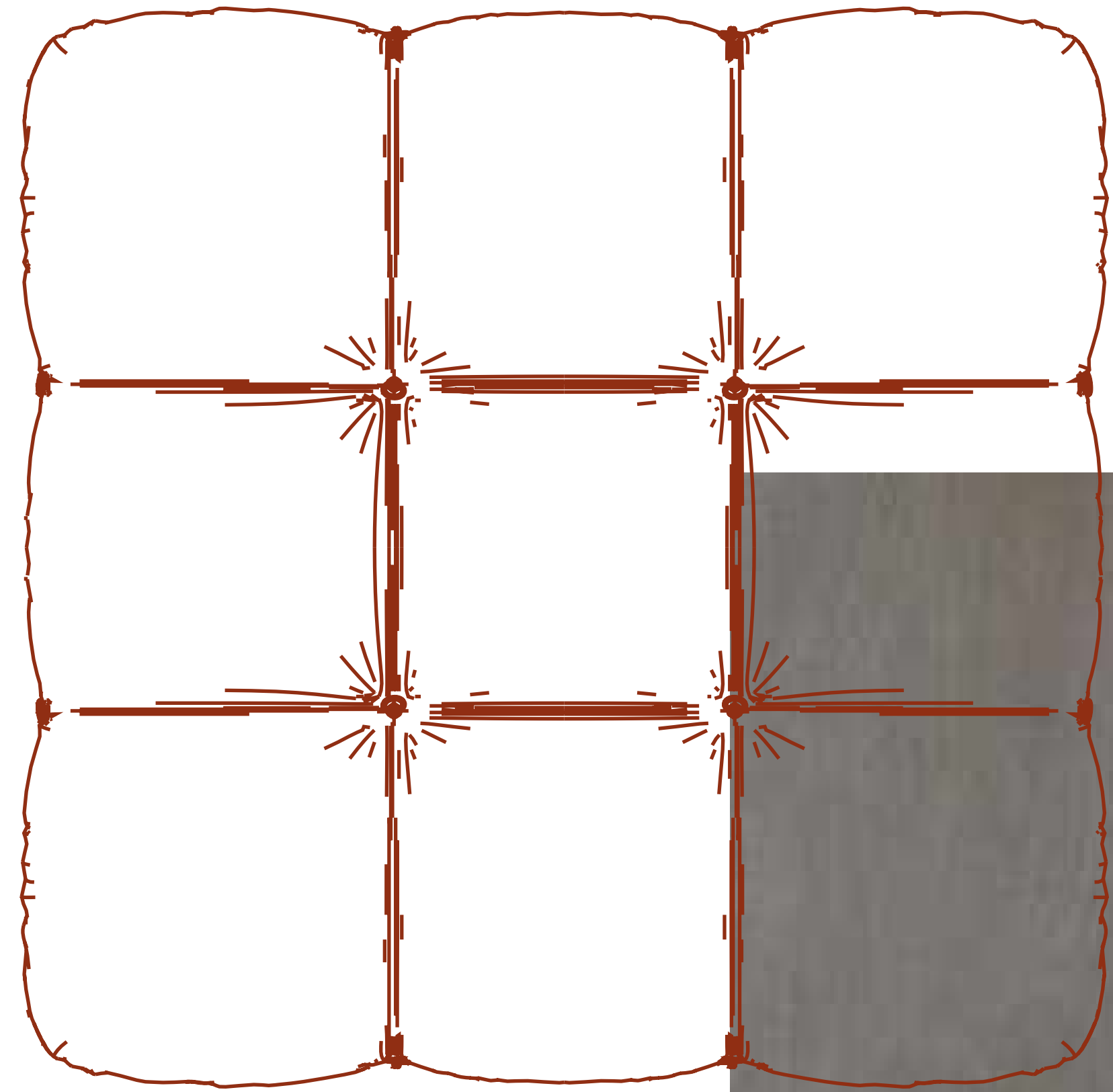

# Bougainvillea pink



# Bougainvillea pink - B&B Italia fabrics

Dedicated fabric\_Tessuto dedicato



Enia 777

Leather\_Pelle



Koto 750

Fabric\_Tessuto



Ego 750



Serra 680



Sirio 755



Sirio 790

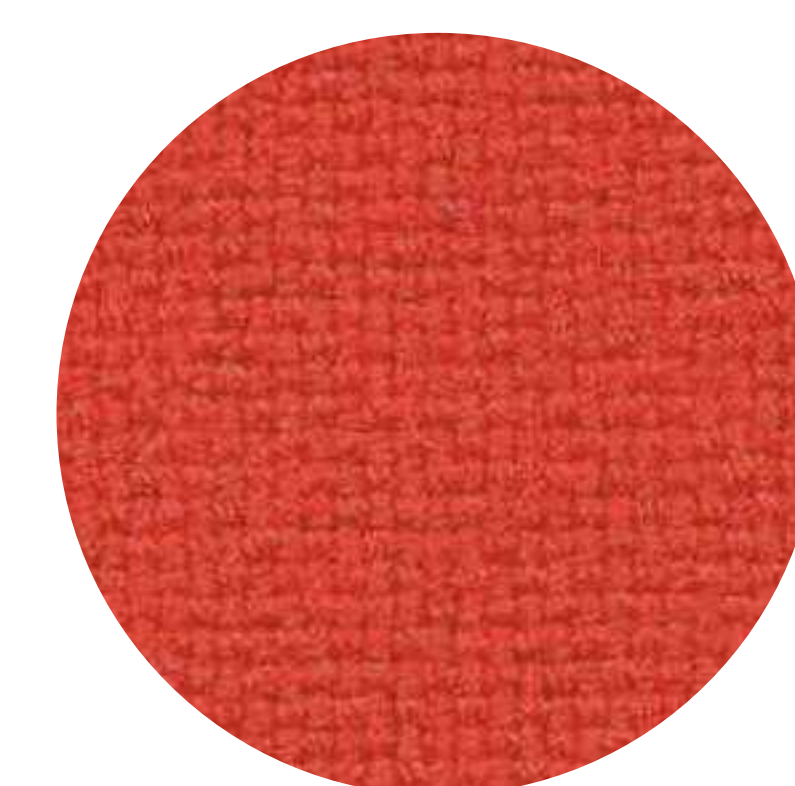

Sidro 700

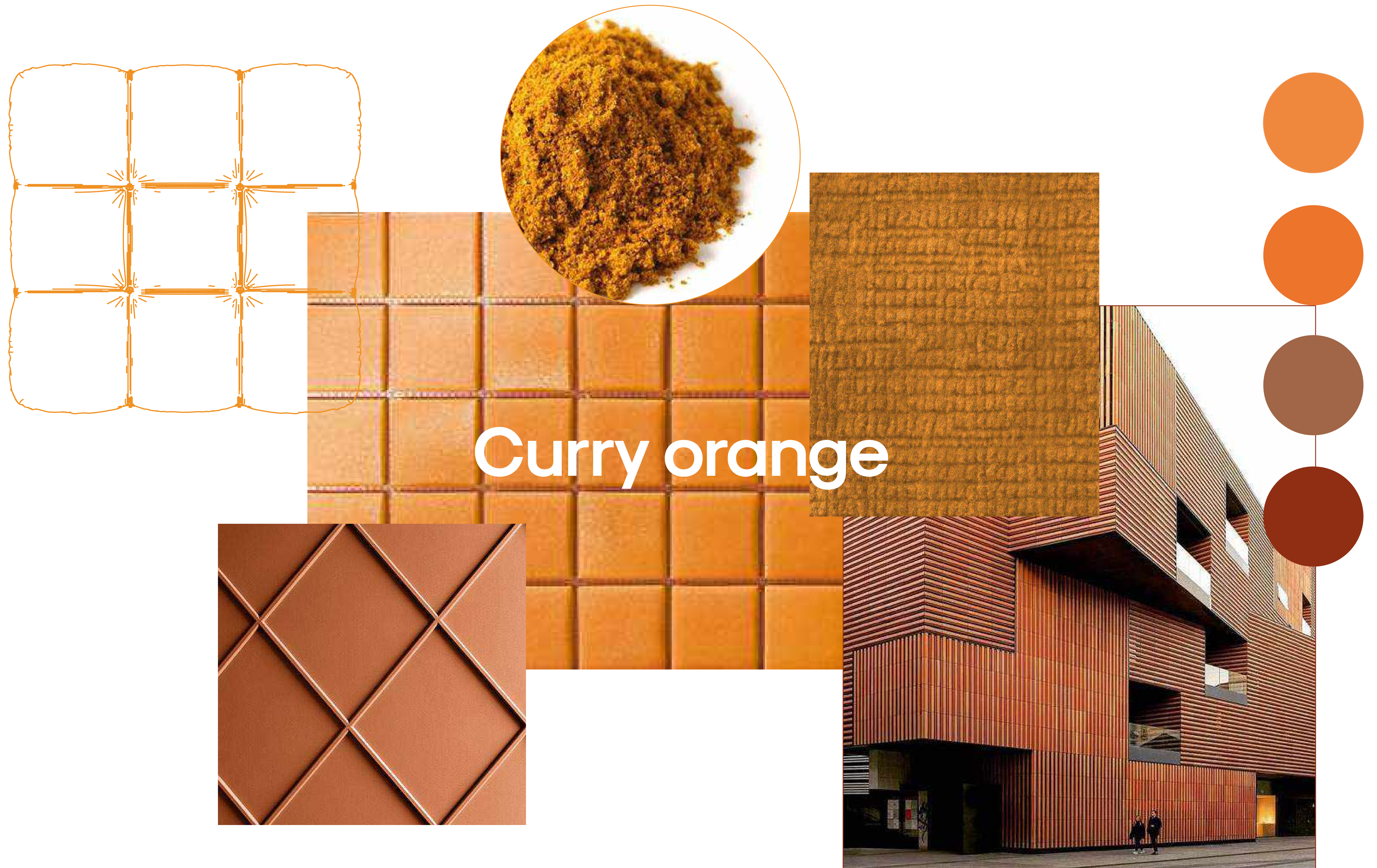

# Curry orange - B&B Italia fabrics

Dedicated fabric\_Tessuto dedicato



Enia 571

Leather\_Pelle

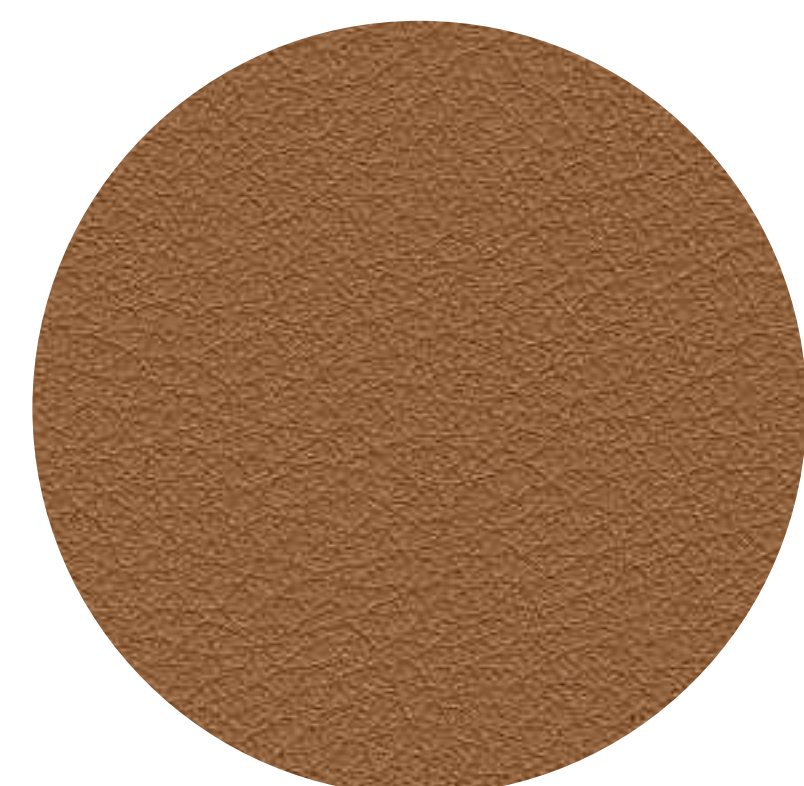

Kasia 310

Fabric\_Tessuto

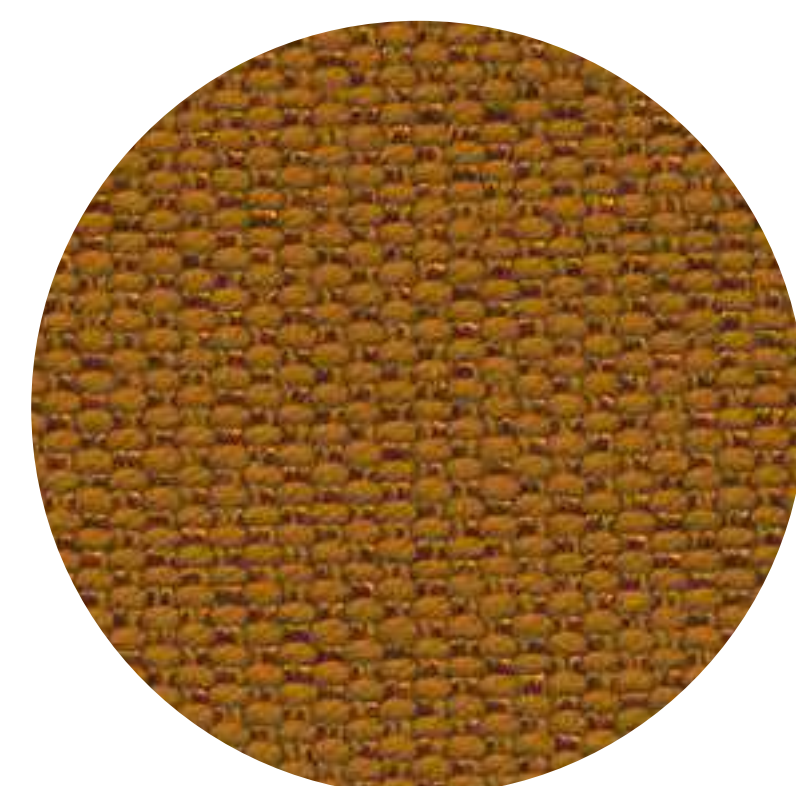

Este 450

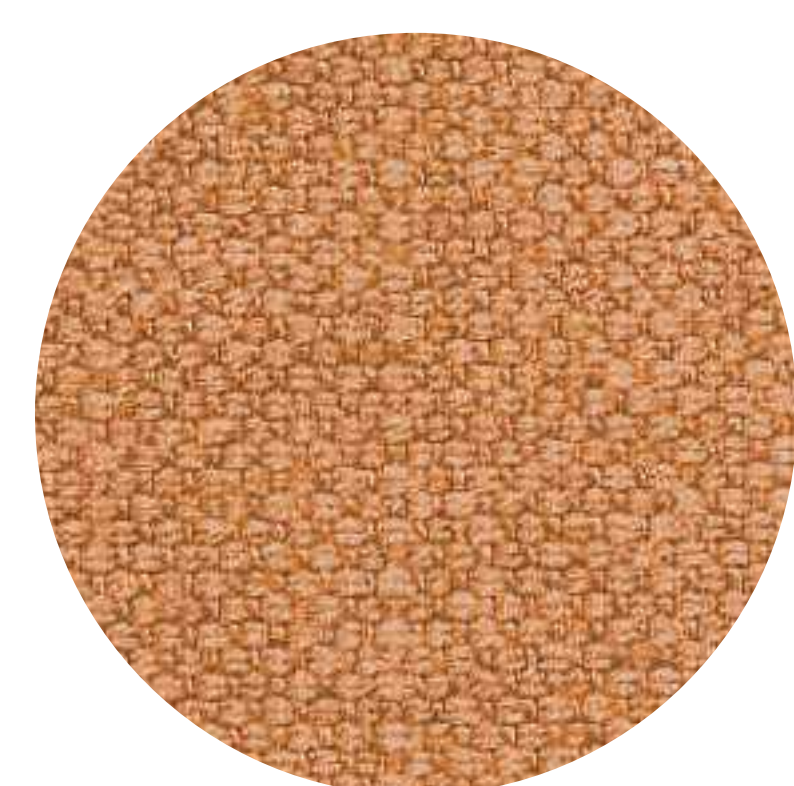

Asolo 450



Licata 333



Elmas 570



Elmas 797

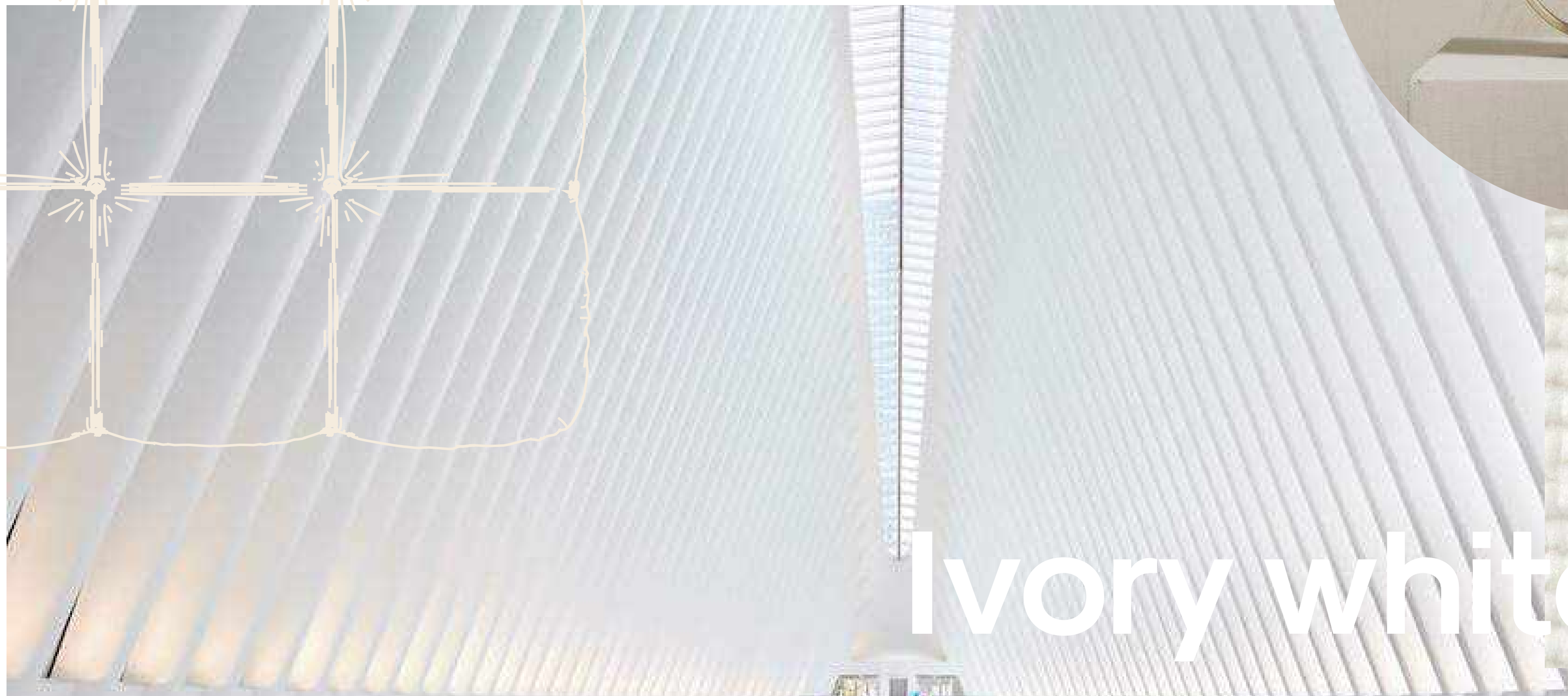
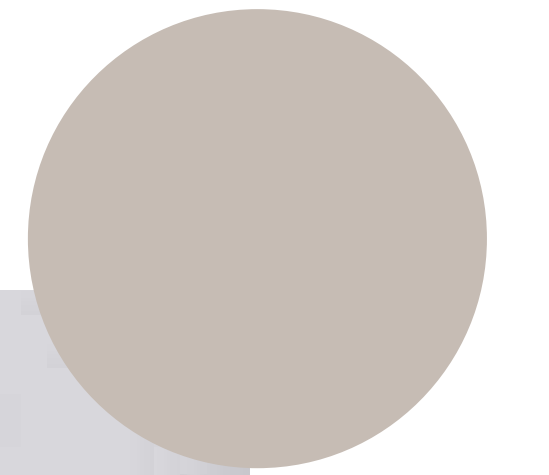
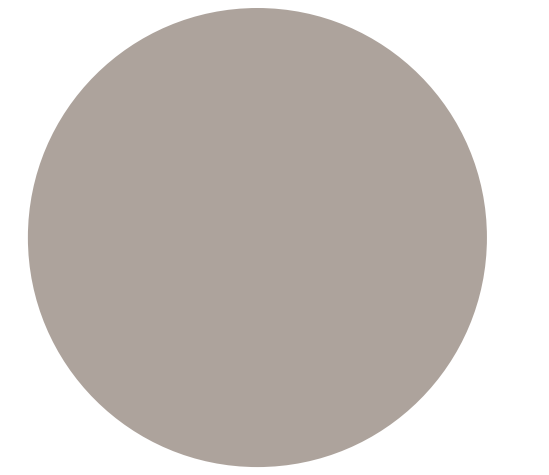
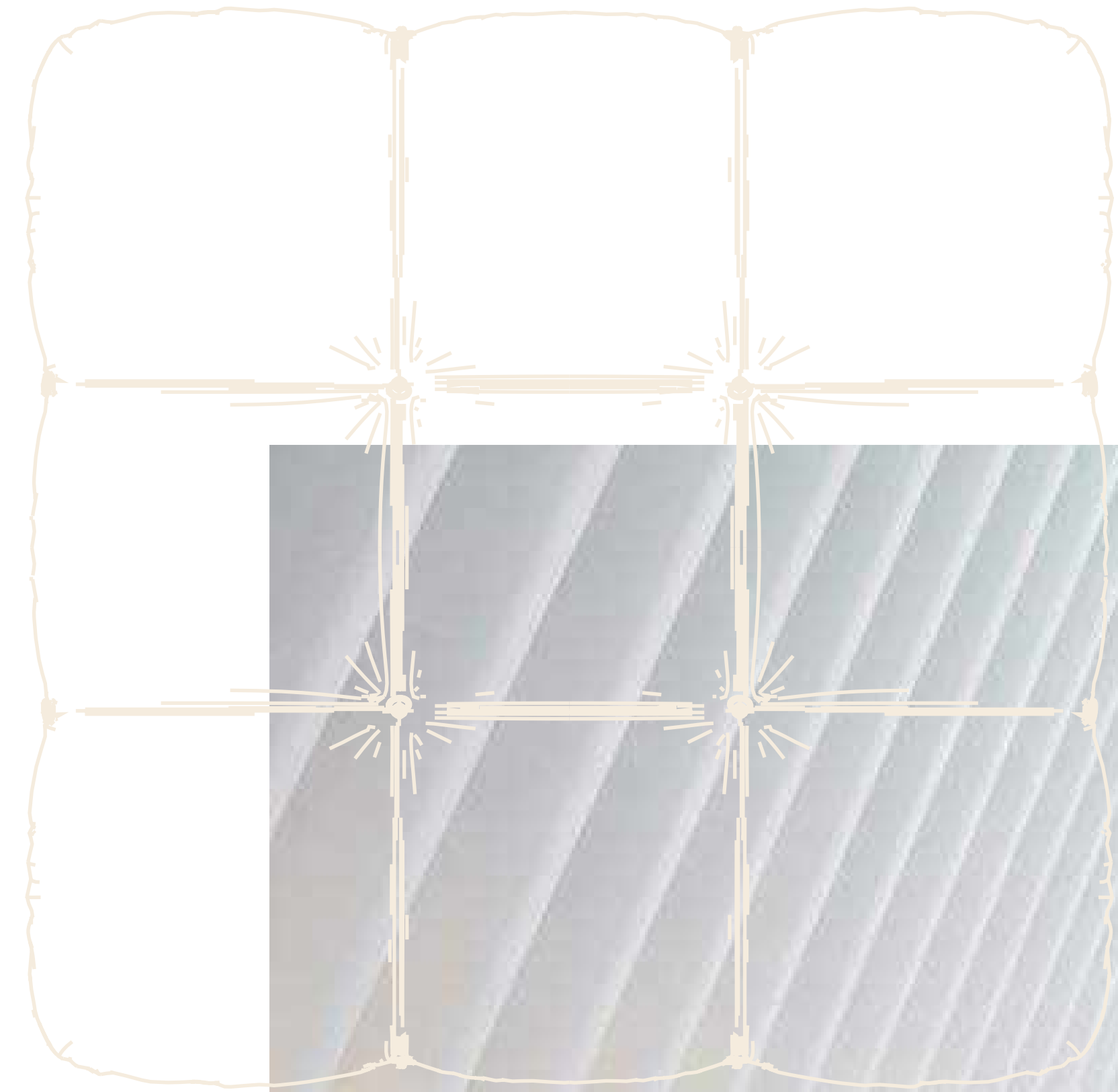

Ivory white





# Ivory white - B&B Italia fabrics

Dedicated fabric\_Tessuto dedicato



Enia 103

Leather\_Pelle



Gamma 101

Fabric\_Tessuto



Ego 100



Sarabi 100



Lari 103



Lodi 100



Milo 200

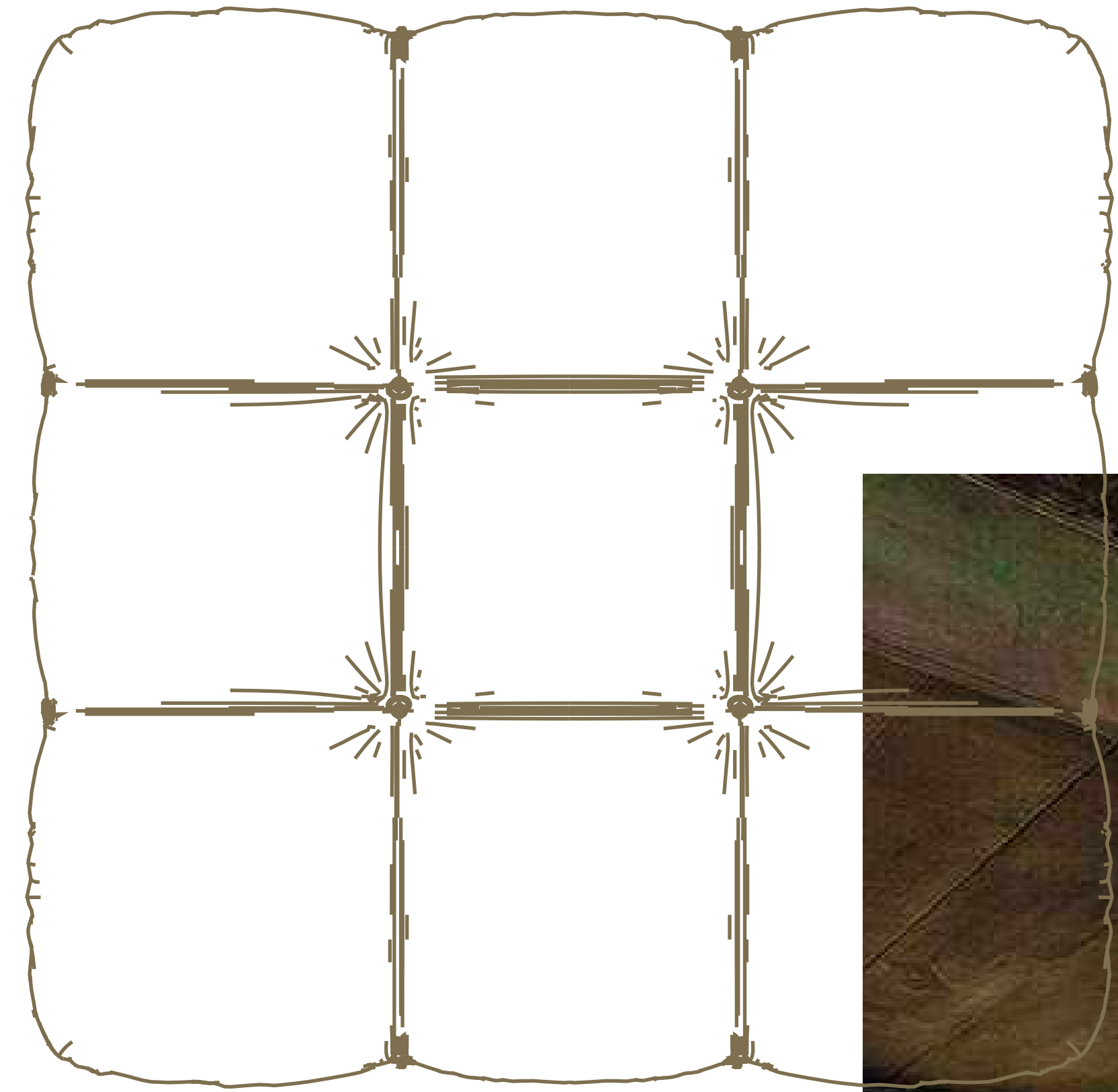

# Olive green



# Olive green - B&B Italia fabrics

Dedicated fabric\_Tessuto dedicato



Enia 400

Leather\_Pelle

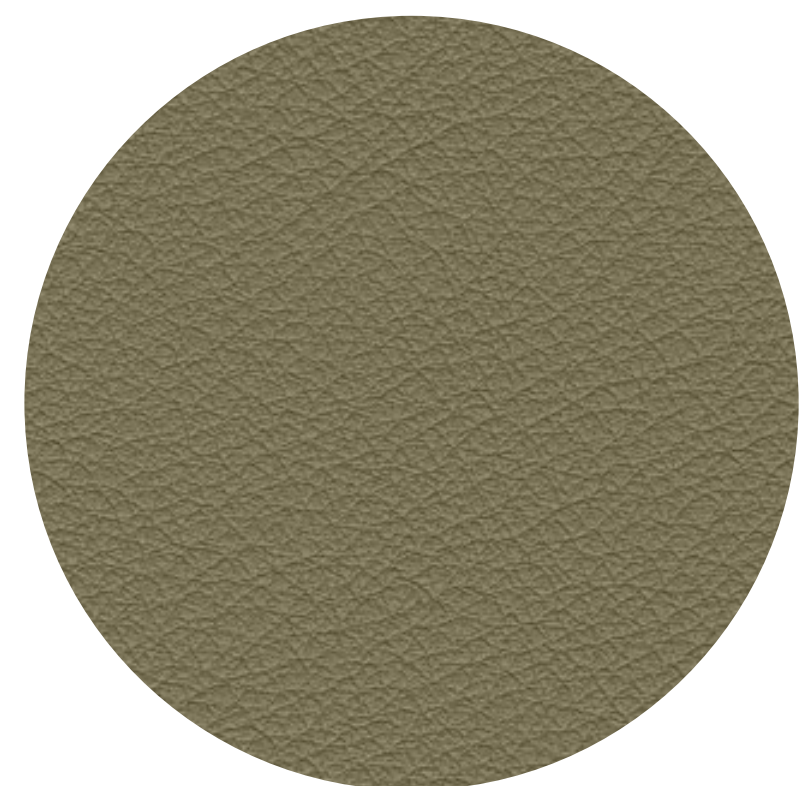

Kasia 401

Fabric\_Tessuto



Esopo 435



Licata 410



Licata 470

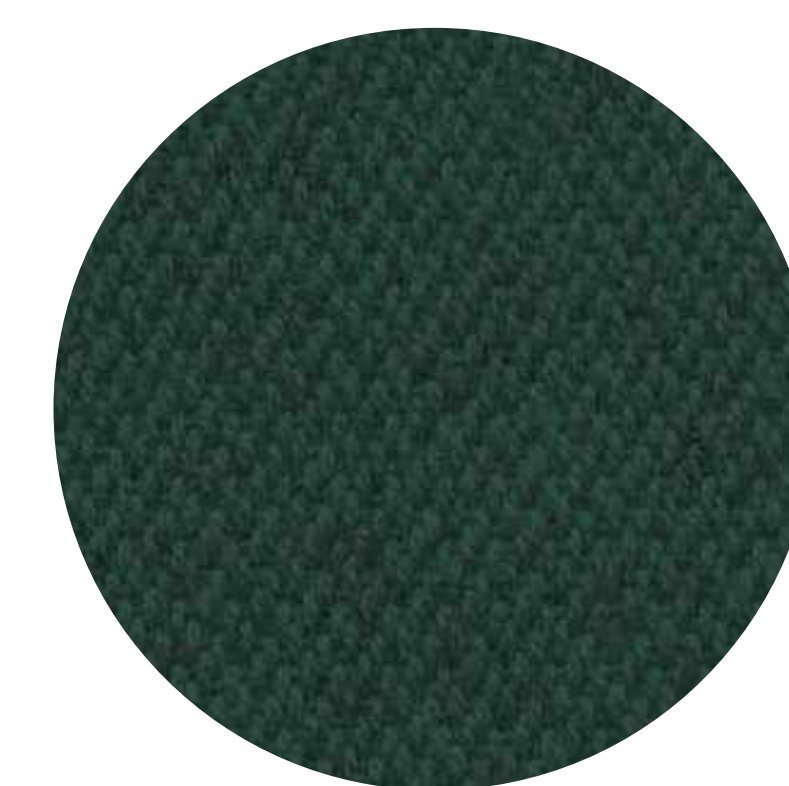

Adria 470

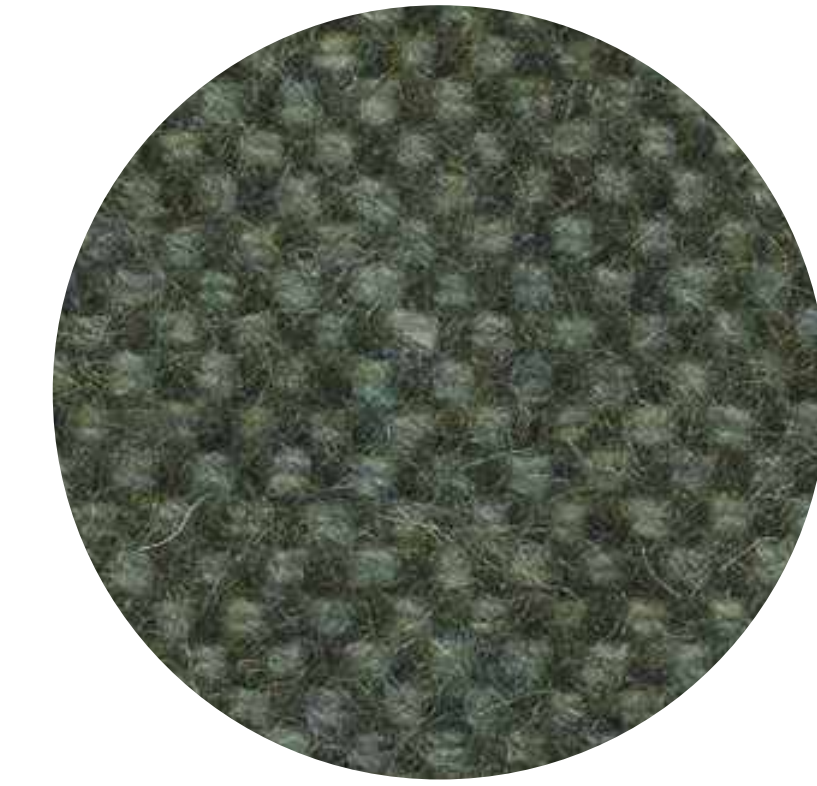

Elmas 435

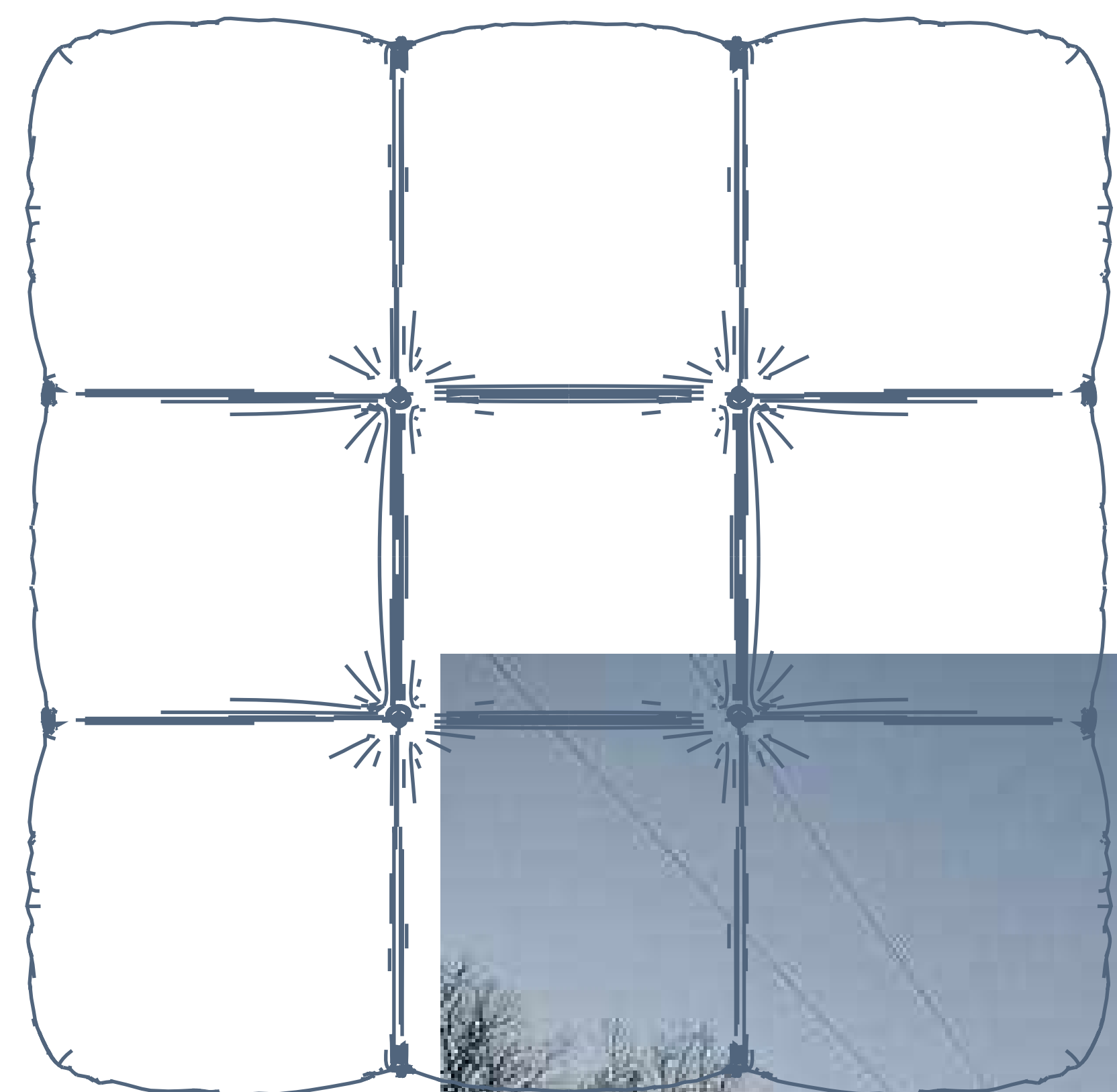

# Abyss blue



# Abyss blue – B&B Italia fabrics

Dedicated fabric\_Tessuto dedicato



Enia 800

Leather\_Pelle



Gamma 154

Fabric\_Tessuto



Sirio 860



Lari 850



Licata 800

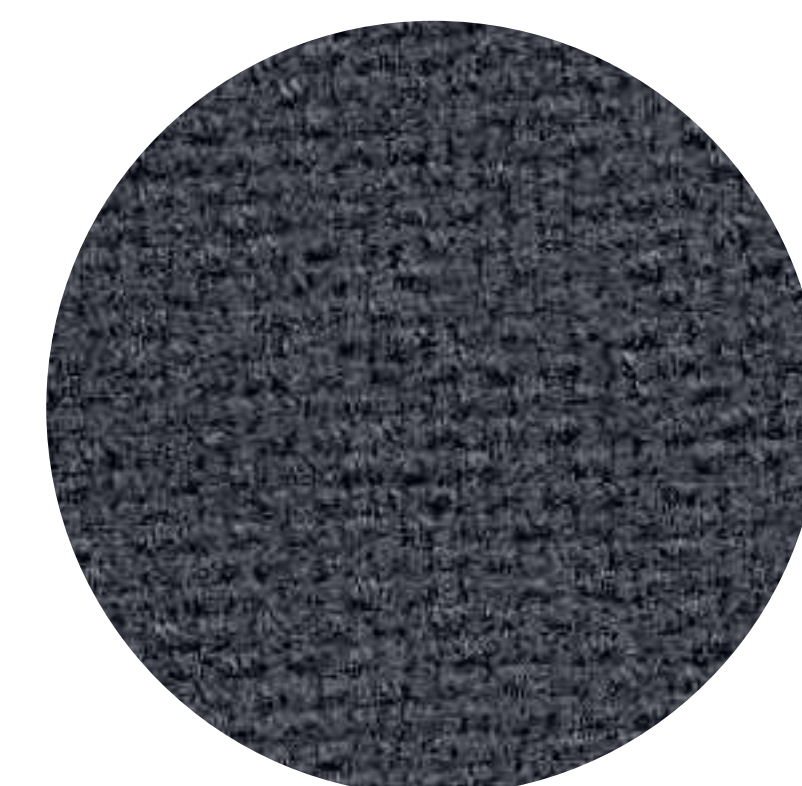

Sidro 153

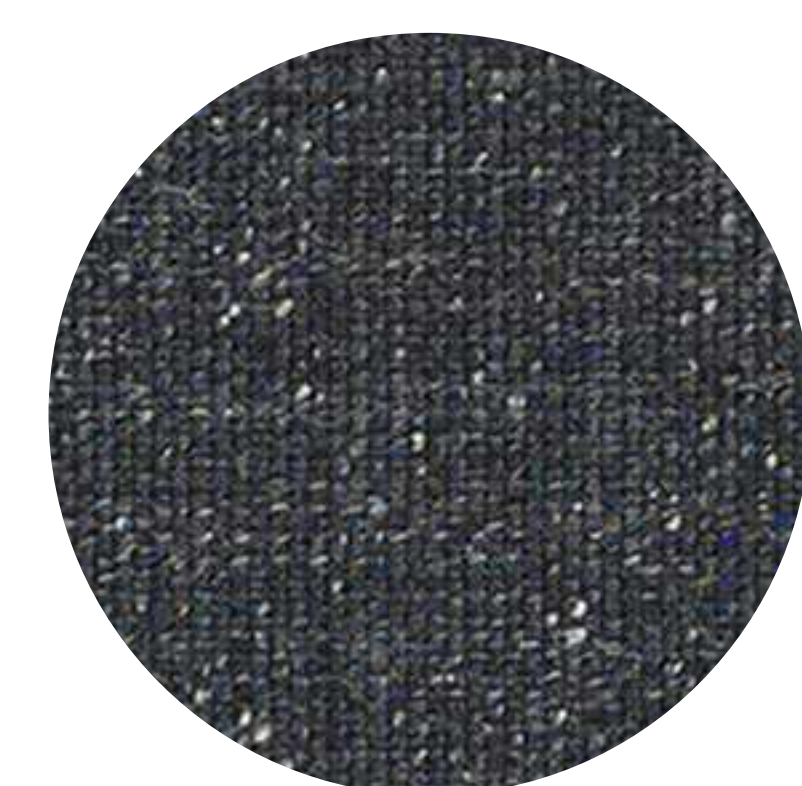

Edit 255

# The present:

## a contemporary reissue

In its reissue, Camaleonda preserves the elements that have made it a contemporary classic. By mutual agreement, Mario Bellini and B&B Italia have decided to keep the 90x90 cm seat module, together with the backrest and the armrest, faithful to the original project, whose original cutting pattern was used for the new edition.

The generous polyurethane padding that forms the characteristic capitonné design remains unchanged, still manufactured with the innovative system of cables, hooks and rings created by Bellini in 1970, which defines the characteristic look and modularity. Thanks to the tie-rods and the rings, in fact, the modules can be unhooked and recombined at will, allowing the sofa to adapt to an evolving taste and the dynamic needs of those using it.

The fundamental characteristic of Camaleonda is its unlimited modularity, a geometric pattern that allows each element to become a sort of enormous pixel through which to define your home environment. By hooking and unhooking seats, backrests and armrests, you can enjoy the luxury of changing your mind as many times as you desire, moving and redesigning the space. A concept which is dear to Mario Bellini: "Of all the objects I have designed, Camaleonda is perhaps the best in terms of its sense of freedom. There are infinite number of possible configurations."

The padding has been thoroughly updated by the B&B Italia's Research & Development Centre, making it even more comfortable than the original version. Thus the magical balance between the rigorous geometry of

the square and the welcoming roundness of the padding is confirmed, further underlining the elasticity and tactile ergonomics that characterize many of Mario Bellini's design projects. Camaleonda can be upholstered with B&B Italia's entire textile and leather collection, allowing for another variable in the multitude of possible combinations.

Camaleonda is a dynamic, alive and sincere object, not at all enigmatic, that allows for an infinite number of configurations while still maintaining its peculiar and unique identity.

# Il presente:

## la riedizione in chiave contemporanea

Nella sua riedizione, Camaleonda conserva gli elementi che lo hanno reso un classico contemporaneo. Di comune accordo, Mario Bellini e B&B Italia hanno scelto di conservare il modulo di seduta da 90x90 cm, così come lo schienale e il bracciolo, fedeli al progetto originario del quale sono state recuperate anche le dime originali per il taglio del rivestimento.

Resta immutata anche la generosa imbottitura in poliuretano che forma il caratteristico capitonné, anche oggi ottenuto attraverso l'innovativo sistema di cavi, ganci e anelli ideato da Bellini nel 1970, che ne garantiscono aspetto e componibilità. Infatti, grazie a tiranti e anelli, i moduli si possono sganciare e ricombinare a piacere, permettendo al divano di adattarsi al gusto in evoluzione e alle necessità dinamiche di chi lo usa.

Caratteristica fondante di Camaleonda è la sua modularità pressoché infinita, una natura geometrica che consente a ogni elemento di diventare una sorta di gigantesco pixel attraverso il quale definire il proprio ambiente domestico.

Agganciando e sganciando sedute, schienali e braccioli ci si può prendere il lusso di cambiare idea quante volte si vuole, spostando e ridisegnando lo spazio.

Un concetto caro a Mario Bellini: "Tra tutti gli oggetti che ho disegnato Camaleonda rappresenta forse meglio di tutti il senso di libertà. Le configurazioni che si possono fare sono infinite."

Le imbottiture sono state ripensate a fondo dal Centro Ricerche & Sviluppo di B&B Italia, fino a renderlo ancora più confortevole rispetto all'originale. In questo modo si

conferma l'equilibrio magico tra la geometria rigorosa del quadrato e la rotondità accogliente delle imbottiture, a sottolineare ulteriormente l'elasticità e l'ergonomia tattile che caratterizzano molti progetti di design di Mario Bellini.

Camaleonda può essere rivestito attingendo all'intera gamma dei tessuti e pellami B&B Italia, fornendo un ulteriore variabile alla miriade di combinazioni possibili.

Camaleonda è un oggetto dinamico, vivo e sincero, per nulla enigmatico, che si lascia modificare a piacere mantenendo sempre e comunque la sua identità peculiare e unica.

Composition/Composizione\_01/A





Composition/Composizione\_01/B



## Compositions/Composizioni\_01/A

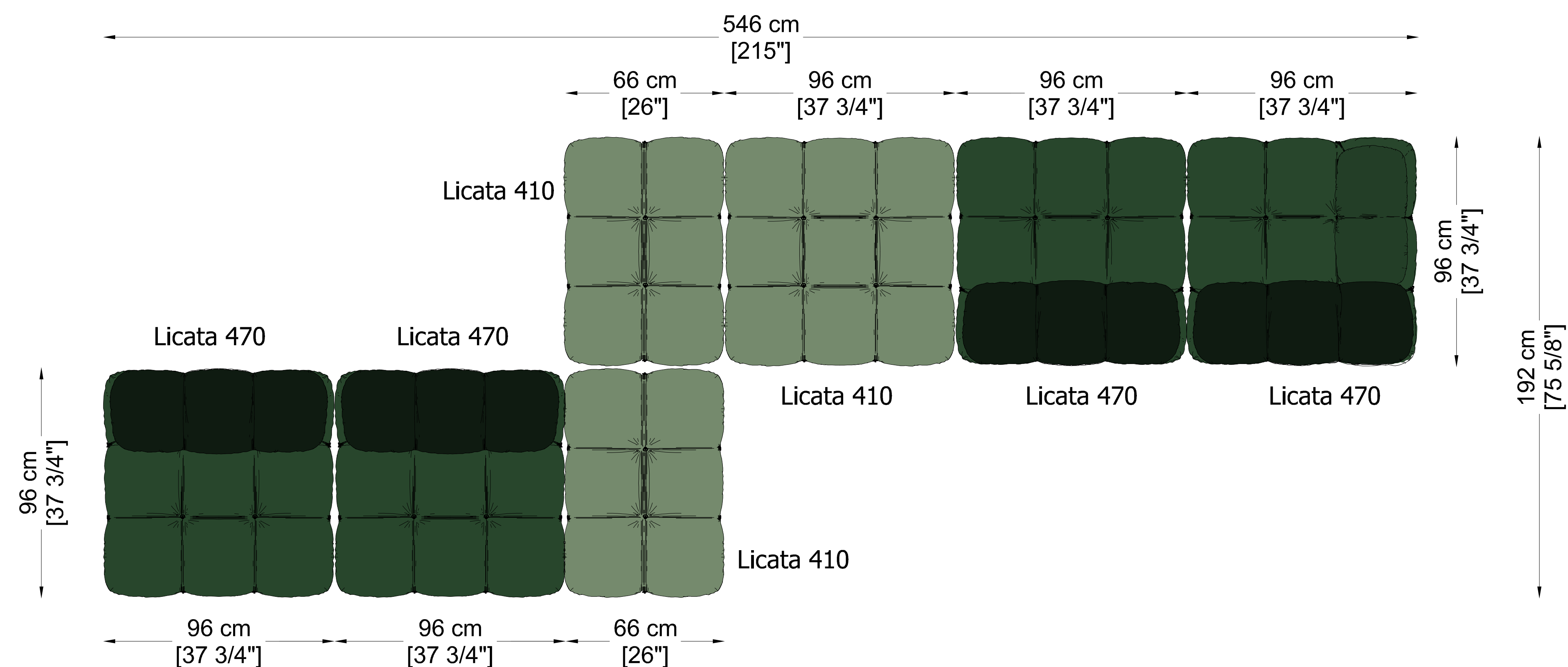

## Composition/Composizione\_01/B

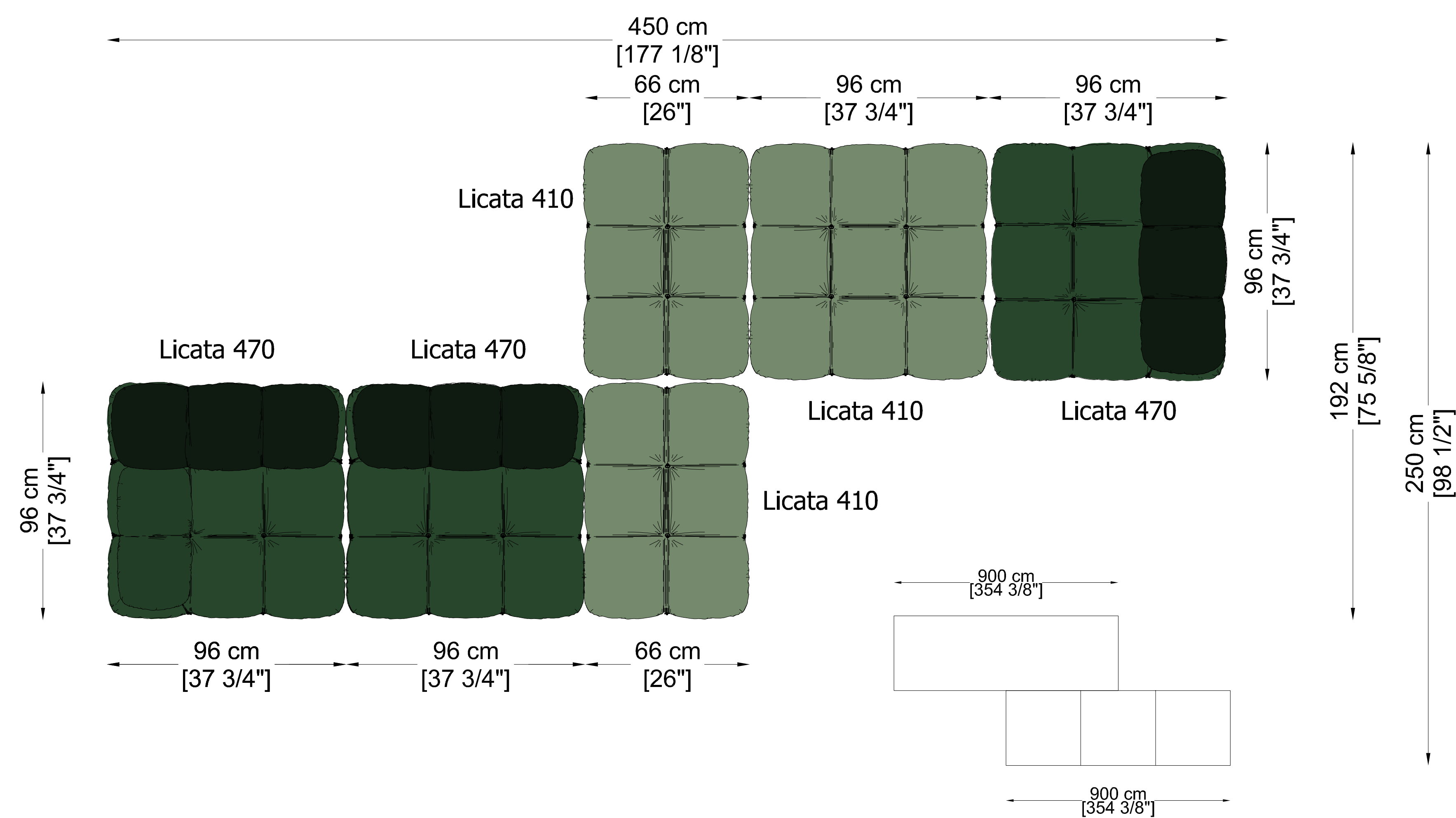

Fabric\_Tessuto



Licata 410



Licata 470

**Composition/Composizione\_02**



## Composition/Composizione\_02

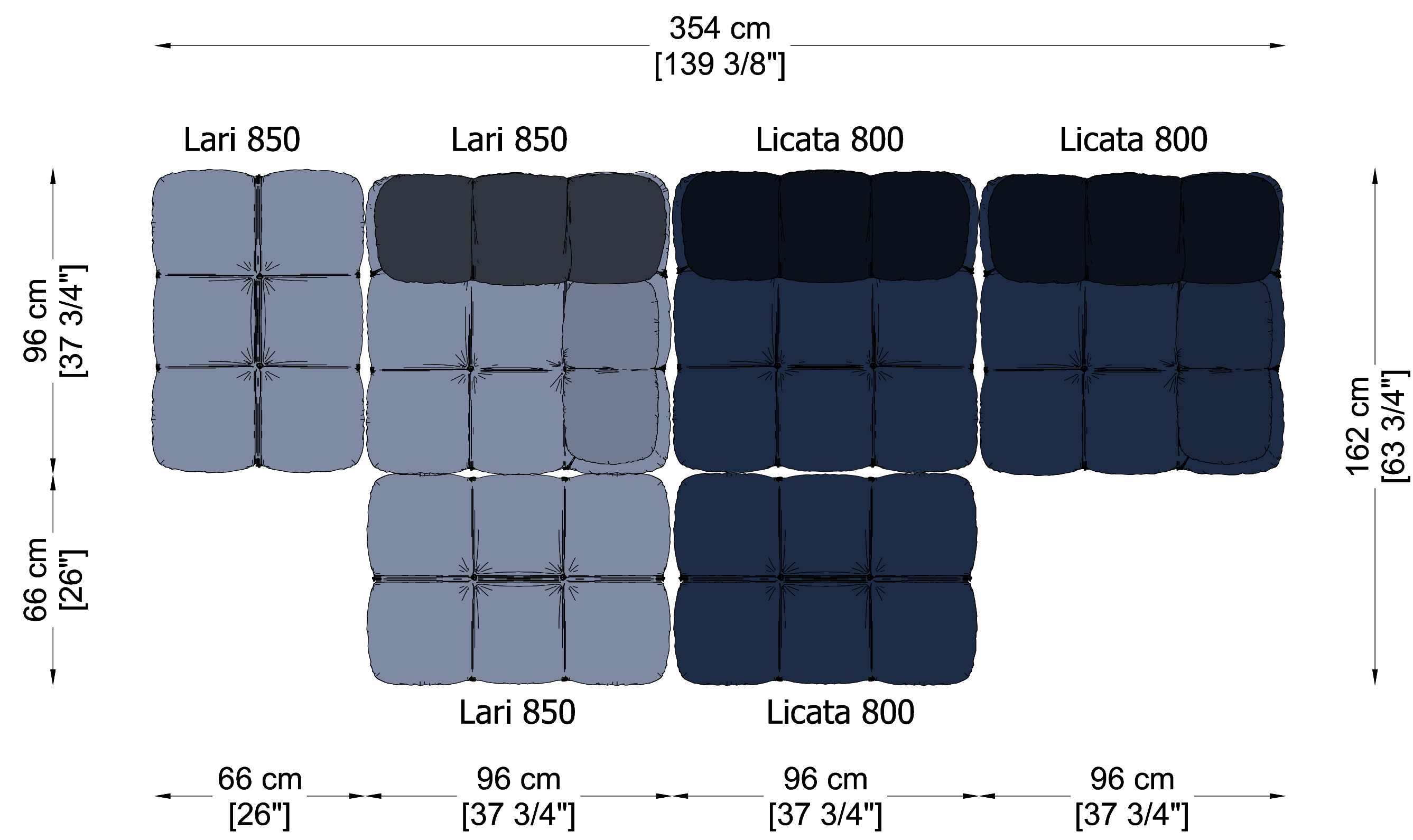

### Fabric\_Tessuto



Lari 850



Licata 800

**Composition/Composizione\_03**



# Composition/Composizione\_03

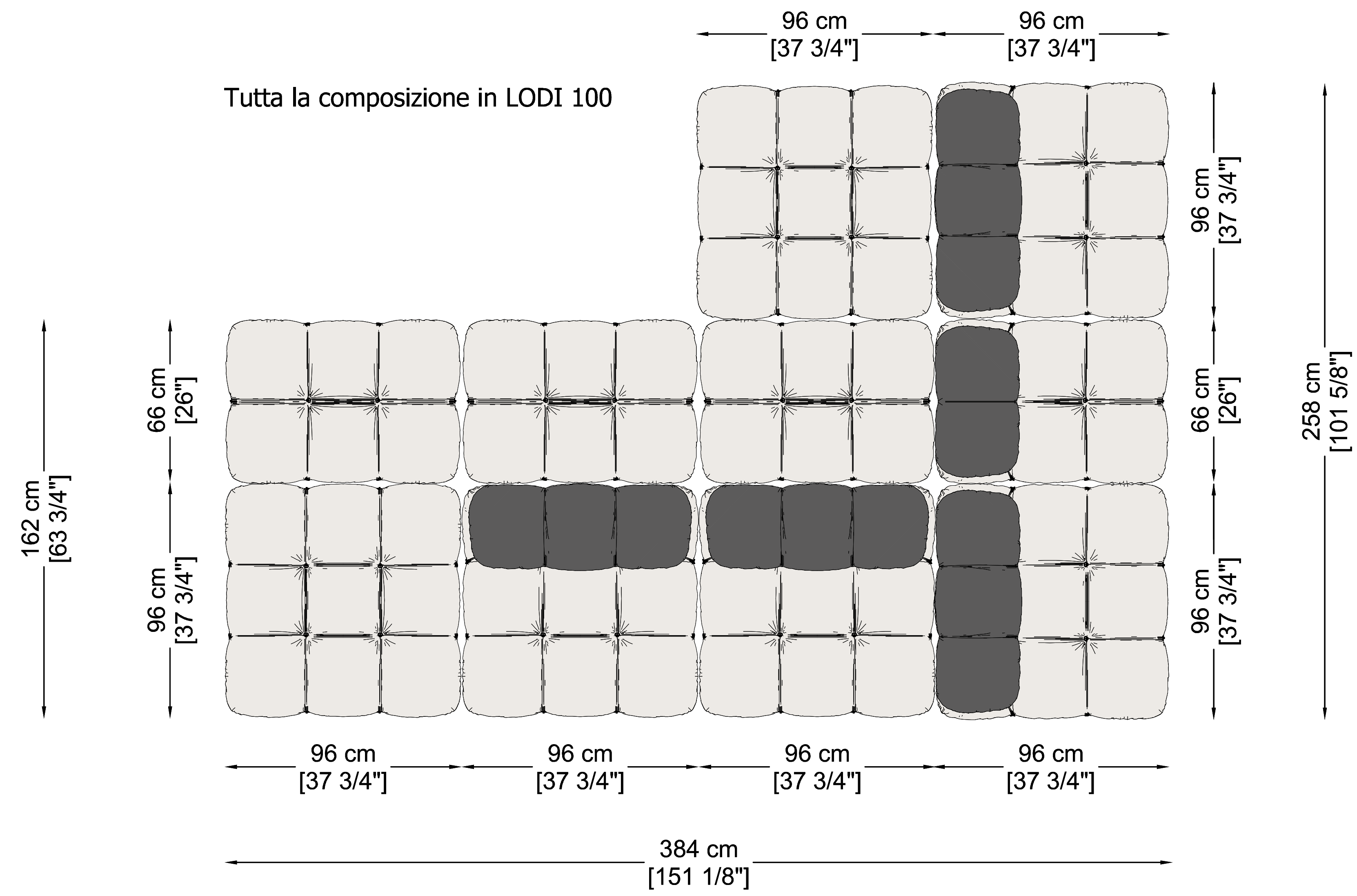

## Fabric\_Tessuto



Composition/Composizione\_05



## Composition/Composizione\_05





**Composition/Composizione\_05**



# Composition/Composizione\_05

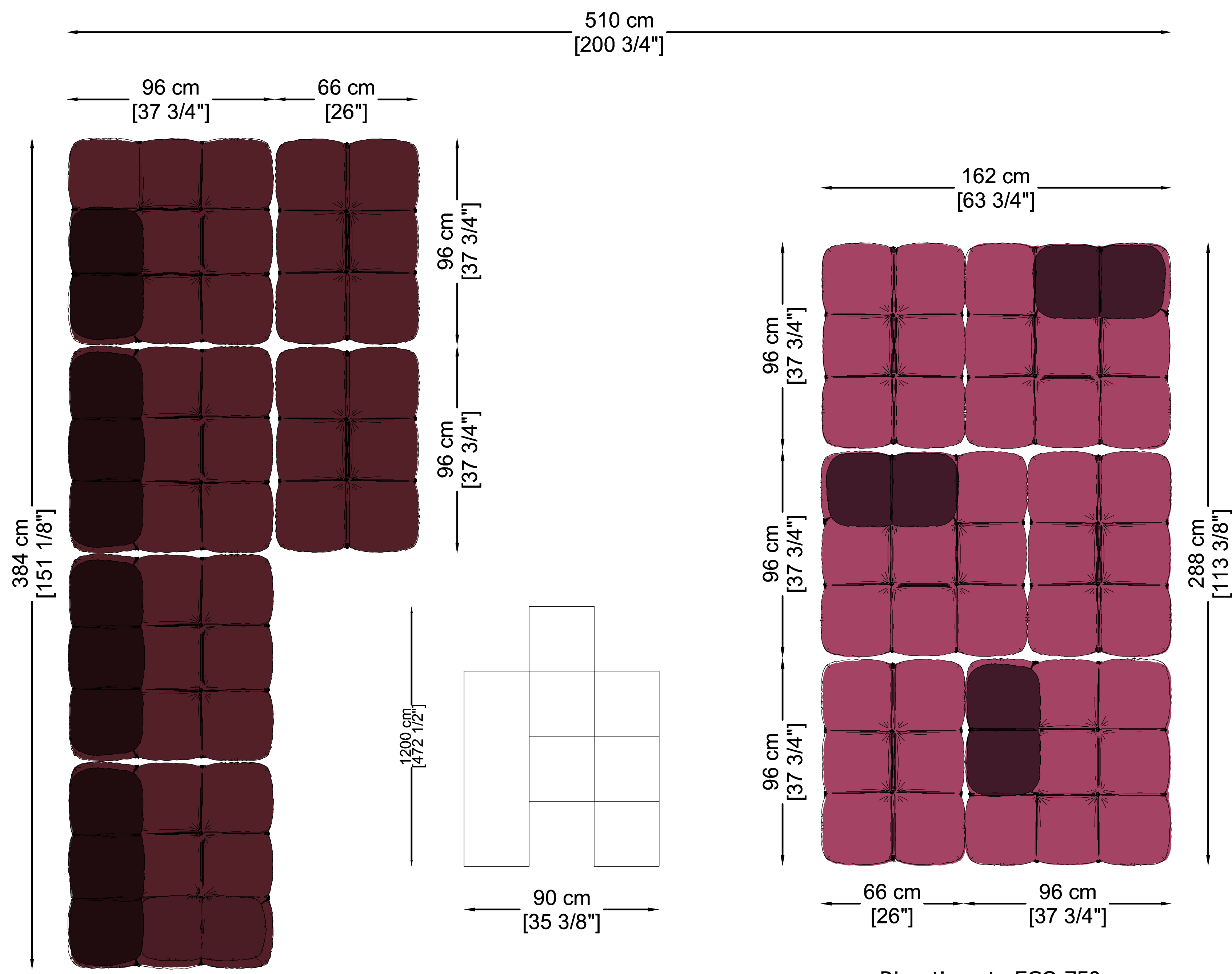

Rivestimento SERRA 680

Rivestimento EGO 750

## Fabric\_Tessuto



Serra 680



Ego 750

Composition/Composizione\_06



# Composition/Composizione\_06

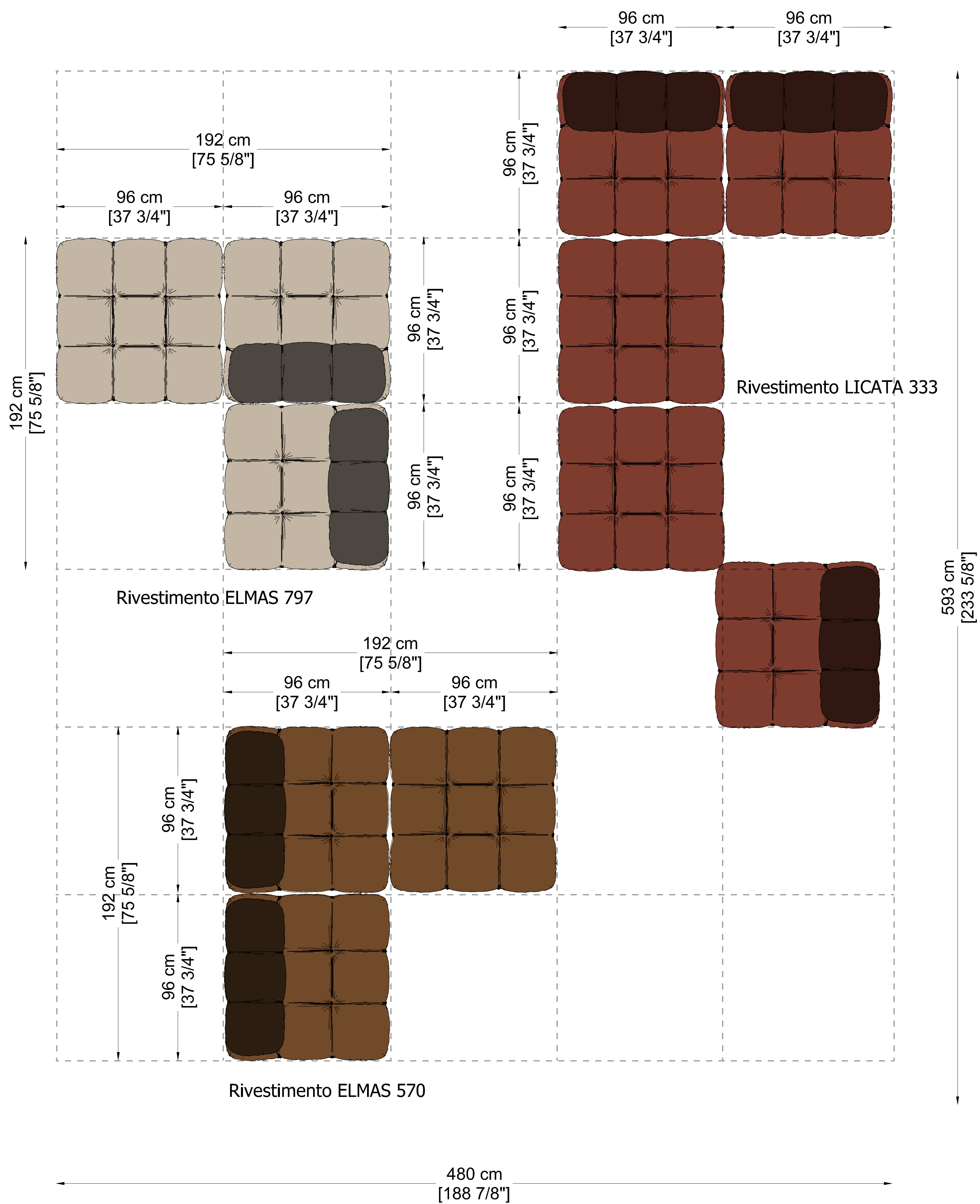

## Fabric\_Tessuto



Elmas 797



Elmas 570



Licata 333

Compositions/Composizioni\_04/A



Compositions/Composizioni\_04/B



**Compositions/Composizioni\_04/B**



### Compositions/Composizione\_04/A

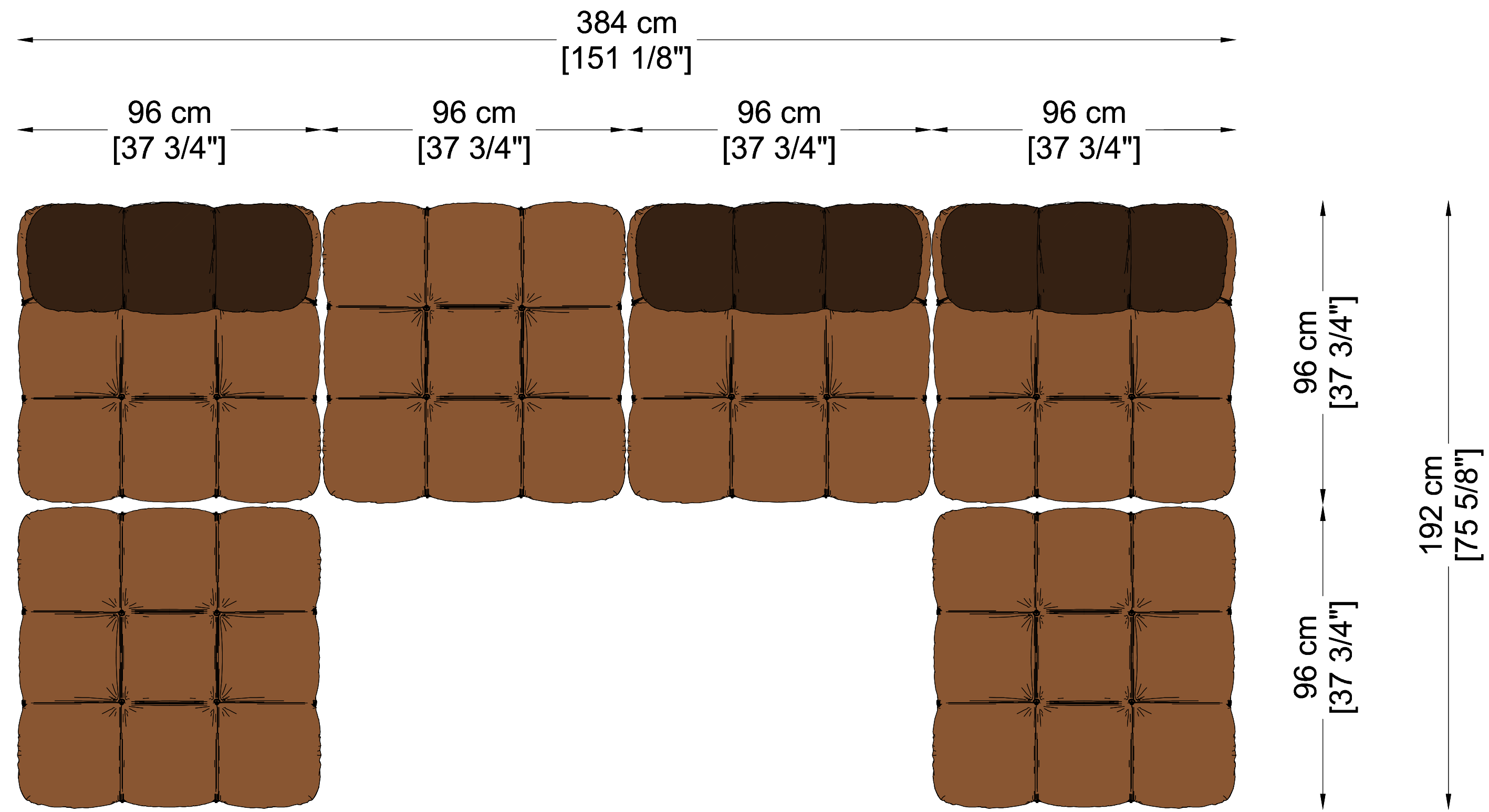

### Compositions/Composizioni\_04/B

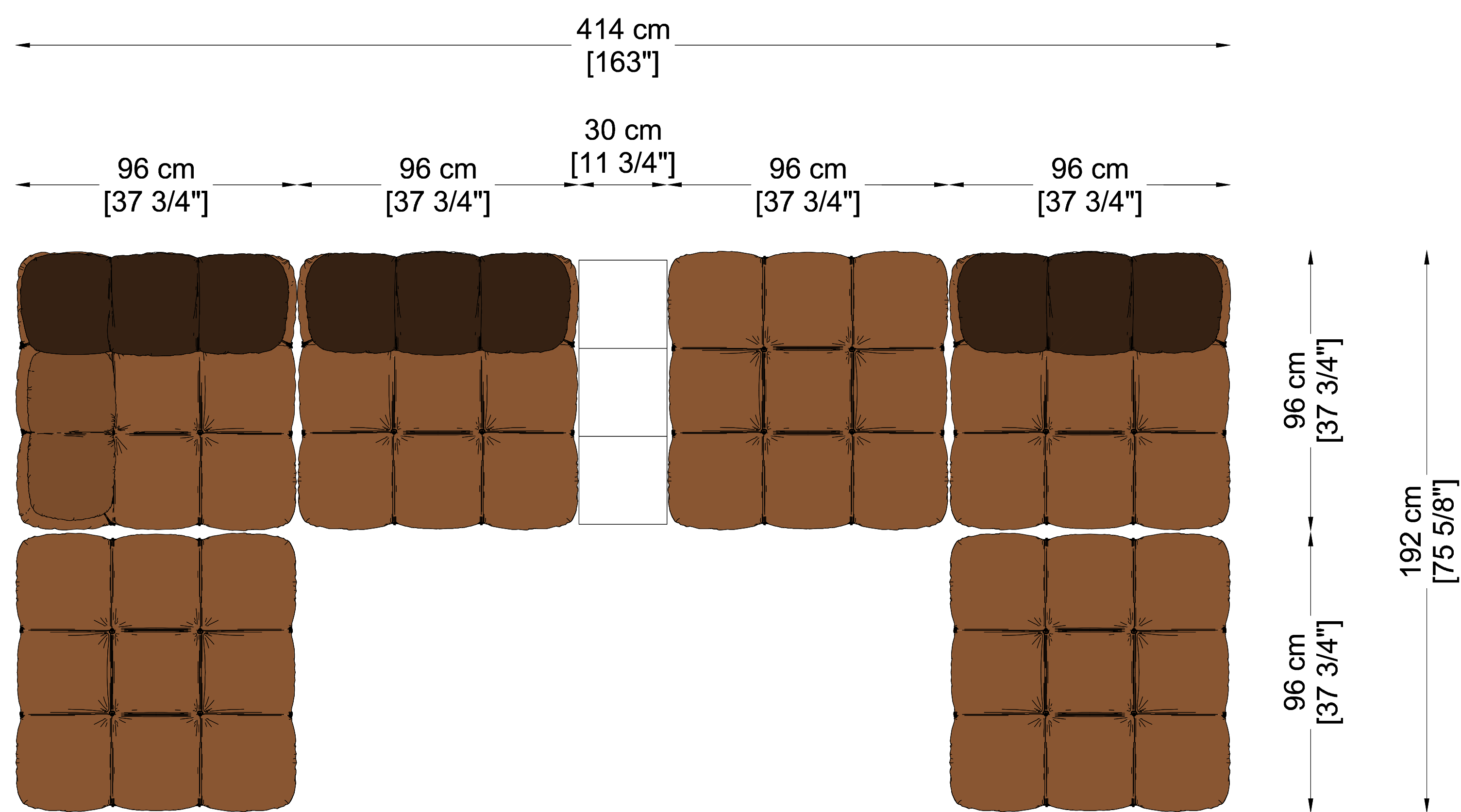

Leather\_Pelle



Kasia 310



**Details**  
Dettagli

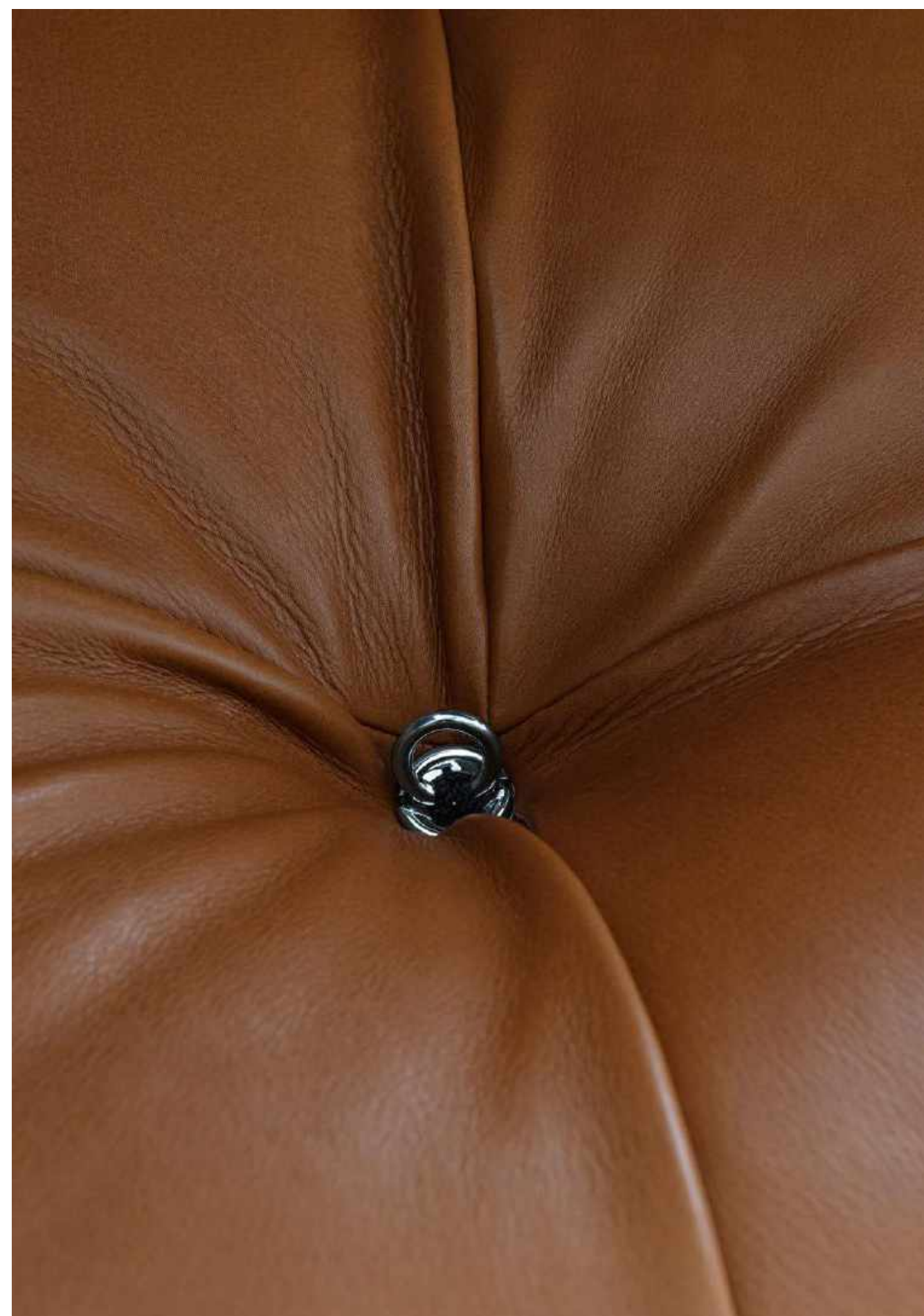

**Tie rod to create the Capitonné effect**  
Tirante per creare l'effetto Capitonné



**Coupling/releasing system between armrest/backrest and seat**  
Sistema di aggancio/sgancio tra bracciolo/schienale e seduta



**Spherical feet in natural FSC beech**  
Piedi sferici in faggio naturale FSC (Forest Stewardship Council)

# The future:

## sustainability and circularity

The re-edition of the Camaleonda does not look back to the past, but on the contrary it aims to rewrite an indisputable classic in a contemporary perspective.

Aesthetics, dimensions, proportions and the way it is configured remain unchanged, while the composition of the interior has been completely redesigned with no room for nostalgia. "When I was asked to update Camaleonda - Mario Bellini declares - it was immediately clear to me that I should never or would never be able to do anything.

Change the shape? No, the way it was intended is as good today as it was then. Change the materials? Yes, and that's why

I had a conversation with a company that is a leader in terms of its ability to transform a piece of furniture into a sustainable product."

The "sandwich" structure of Camaleonda is made up of recycled or recyclable materials that can be easily disassembled.

The seat, backrest and armrests and bases are made of wooden panels. The sofa rests on the floor on a series of spherical feet made of FSC (Forest Stewardship Council) certified beech wood.

The padding of the seat, the backrests and the armrests are made of polyurethane in various levels of density and firmness.

The highest degree of complexity lies in the seat, where elements are shaped and assembled to allow every layer to interact, at the same time guaranteeing a high level of comfort. The various layers generate empty spaces or pockets designed to create a comfortable spring effect.

The engineering and composition of the seat allows the interior elements of the sofa to be disassembled and therefore easily recyclable.

The padding is protected by a removable cover made of dacron, a synthetic fabric that is entirely made of recycled PET, the same material used to manufacture plastic water bottles.

# Il futuro:

## sostenibilità e circolarità

La riedizione di Camaleonda non ci vuole parlare di passato, anzi, punta a rileggere un indiscutibile classico in ottica contemporanea. Estetica, dimensioni, proporzioni e sistema d'uso sono rimasti invariati, ma l'interno è stato completamente riprogettato senza nostalgie.

“Quando mi è stato chiesto di aggiornare Camaleonda - dichiara Mario Bellini - ho avuto subito chiaro in mente che non avrei dovuto e potuto fare assolutamente nulla. Cambiare la forma? No, perché così concepita andava bene allora come oggi. Cambiare i materiali? Sì, e per ciò ho dialogato con un'azienda leader nella

capacità di trasformare in sostenibile un arredo.” La struttura “a sandwich” di Camaleonda si compone di strati costituiti da materiali riciclati o riciclabili, facilmente disassemblabili. La base di partenza di seduta, schienale e braccioli è costituita da pannelli lignei. Il divano poggia sul pavimento con una serie di piedini sferici in legno di faggio certificato FSC (Forest Stewardship Council).

Le imbottiture di seduta, schienali e braccioli sono realizzate in poliuretano a densità e portanza diversificate. La complessità maggiore si trova nella

seduta, i cui elementi sono sagomati in modo da incastrare e far interagire ogni strato, garantendo allo stesso tempo una comodità assoluta. I diversi strati generano spazi vuoti congegnati a creare un confortevole effetto molla. Questa scelta ingegneristica permette inoltre di rendere l'interno del divano disassemblabile e perciò facilmente riciclabile.

L'imbottitura è protetta da un rivestimento removibile in dacron, tessuto sintetico interamente riciclabile ottenuto da PET riciclato, lo stesso materiale con cui sono realizzate le comuni bottiglie in plastica.

## Sustainability and circularity

### Sostenibilità e circolarità

Product blanking: double layer of 400 gr polyester fiber derived from PET obtained from the recovery of plastic bottles and synthetic fibers (100% recyclable). The cover will not be stapled or nailed, like the original, to the wooden panel. It will be easily removable (and recyclable).

Layered polyurethane of different densities create a sandwich seat avoiding the use of frames, straps and adhesives. The union between one layer and another is guaranteed by the particular interlocking geometry that allows to obtain a spring effect between the different layers.

High quality wooden panel made from 100% circular wood from waste streams from the wood industry and sustainable forestry.

Spherical feet in natural FSC beech (Forest Stewardship Council)



Messa in bianco del prodotto: doppio strato di fibra di poliestere da 400 gr derivata da PET ottenuta dal recupero di bottiglie di plastica e fibre sintetiche (100% riciclabile). La fodera non verrà graffettata o inchiodata, come l'originale, al pannello di legno. Risulterà facilmente removibile (e riciclabile).

Poliuretano a strati di densità differenziata crea una seduta a sandwich evitando l'utilizzo di telai, cinghie e collanti. L'unione tra uno strato e l'altro è garantita dalla particolare geometria ad incastro che permette di ottenere un effetto molla tra i diversi strati.

Pannello ligneo di alta qualità realizzato al 100% con legno circolare proveniente da flussi di rifiuti dell'industria del legno e dalla silvicoltura sostenibile.

Piedi sferici in faggio naturale FSC (Forest Stewardship Council)

**Leather/fabric cut layout for module 90x90 cm**  
Schema taglio pelle/tessuto per modulo 90x90 cm

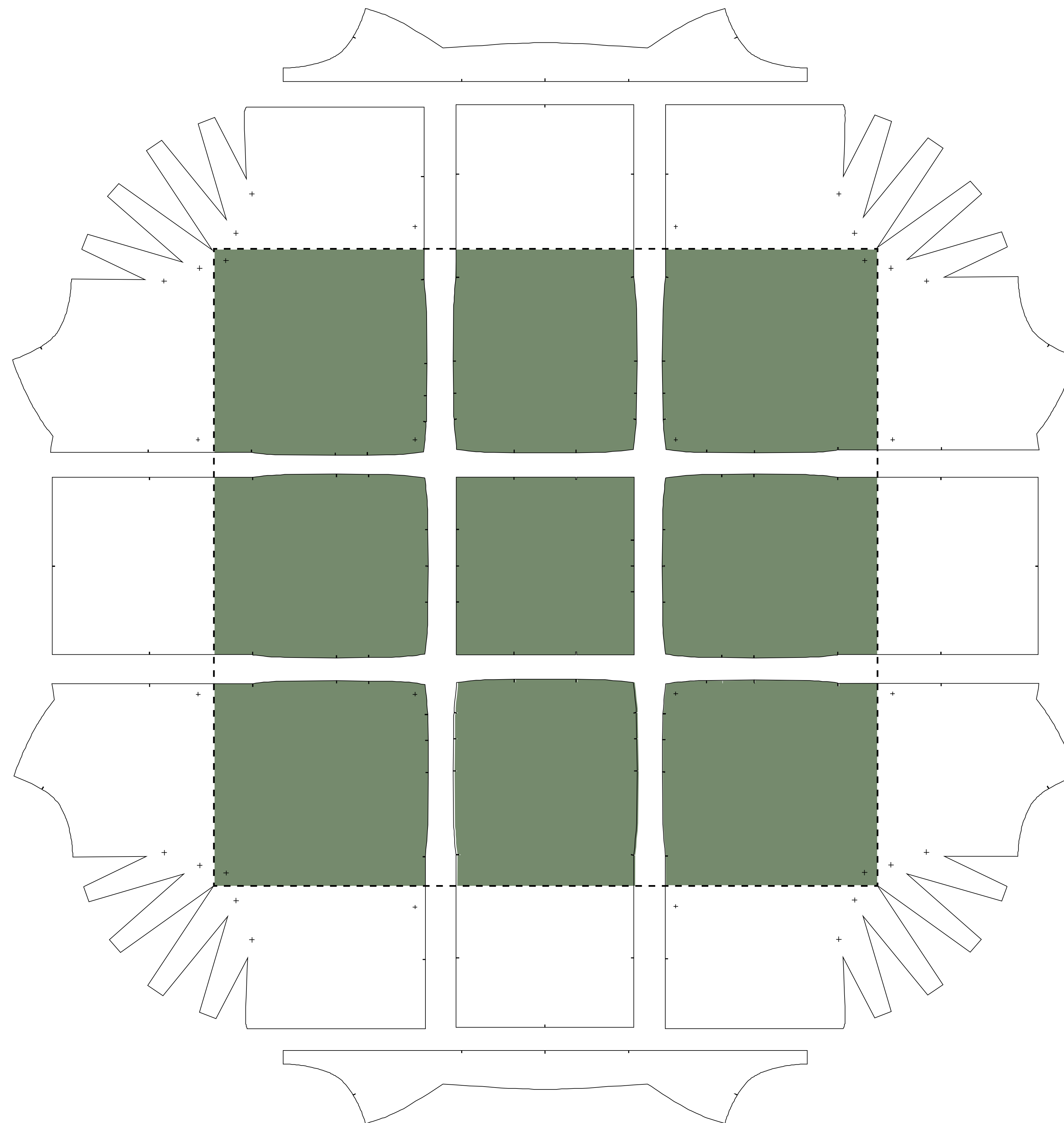

Abaco  
Abaco

Central  
Centrali

CM96C

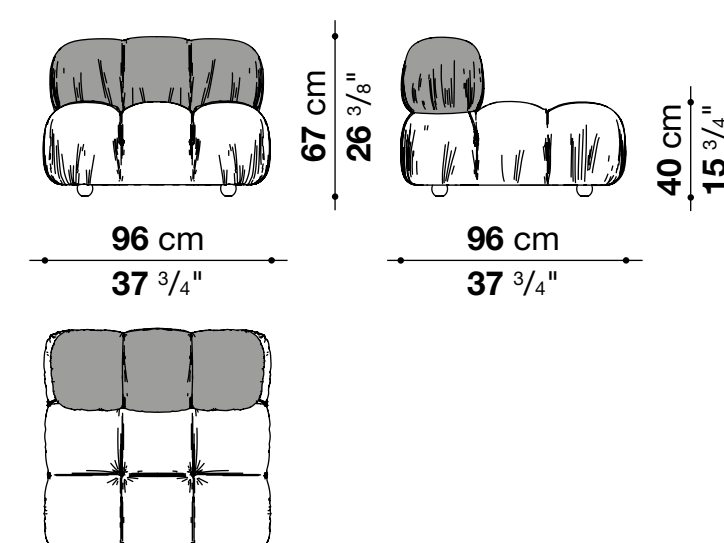

CM96B\_C

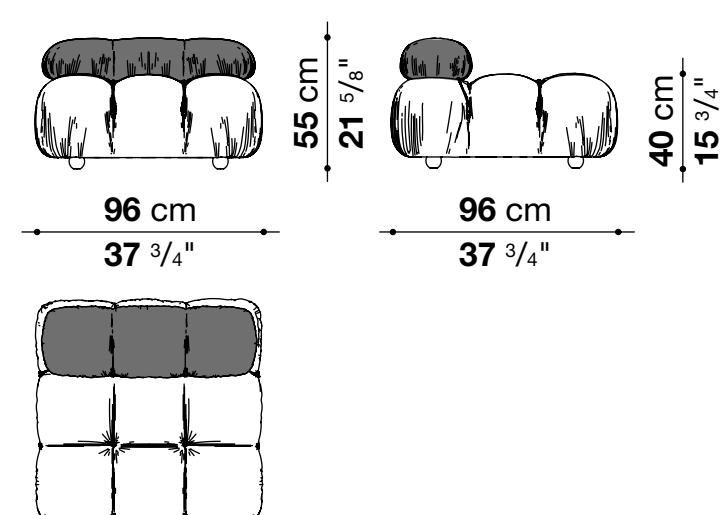

CM66C

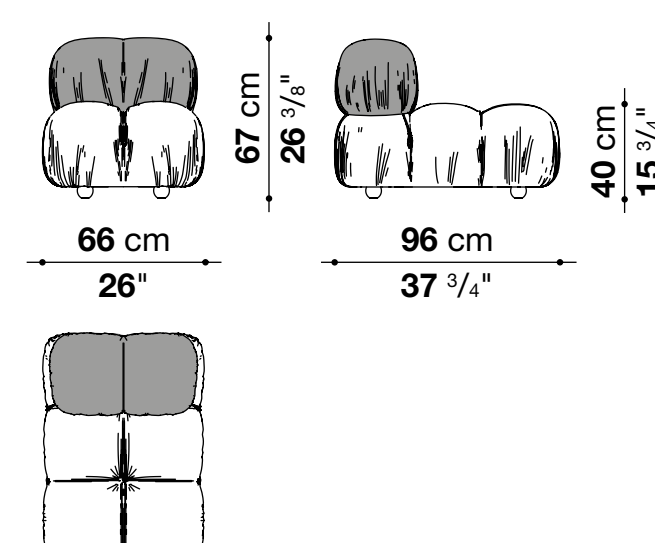

CM66B\_C

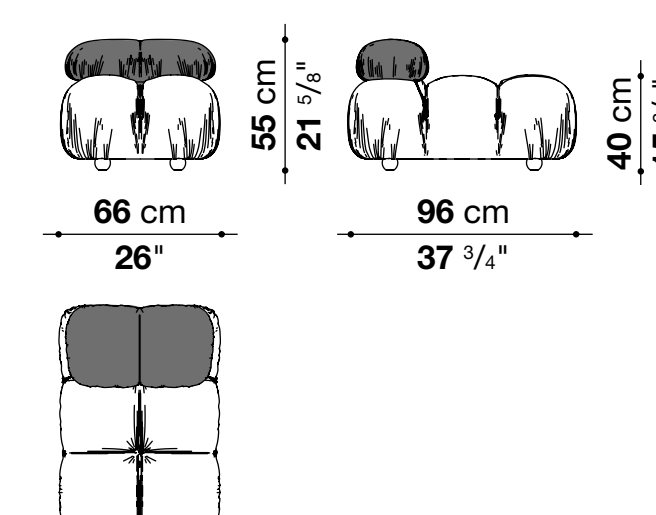

Terminal  
Terminali

CM96B\_TS1

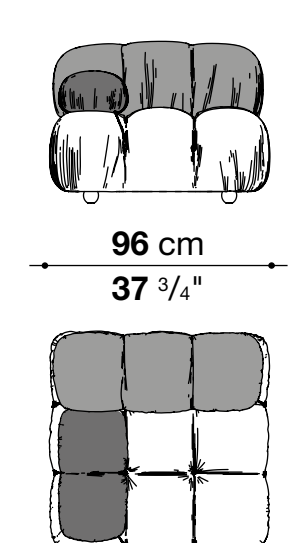

CM96B\_TD1

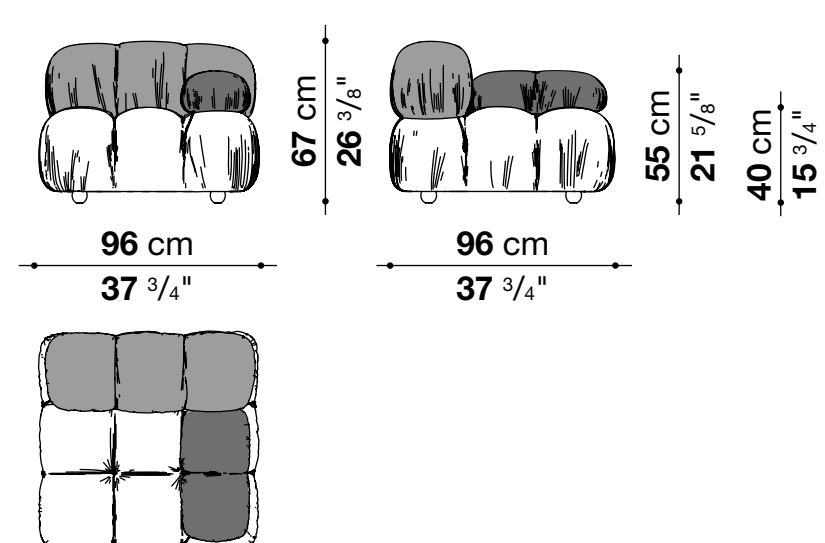

CM96B\_TS2

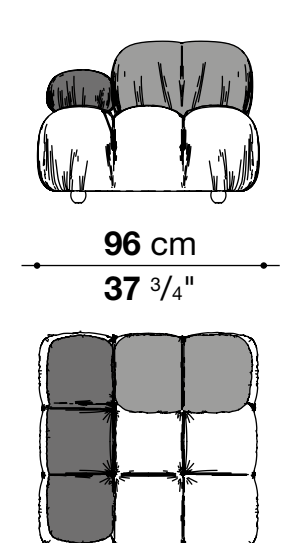

CM96B\_TD2

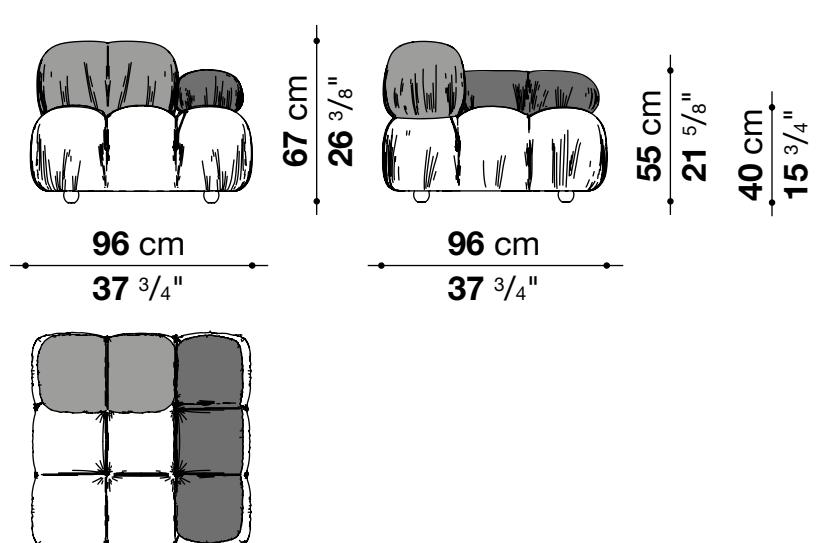

Corner  
Angolari

CM96AS

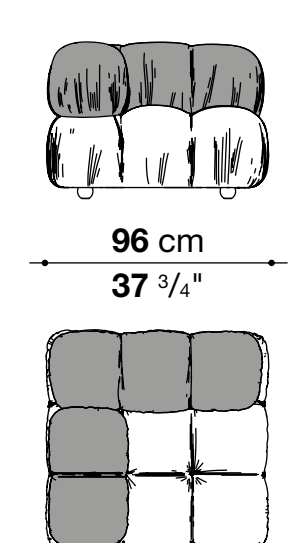

CM96AD

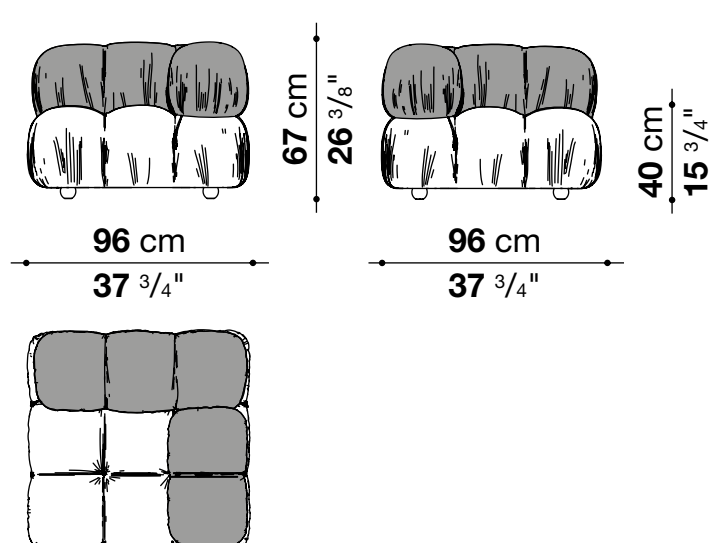

CM96B\_AS

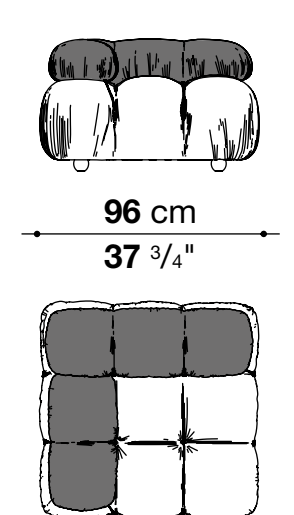

CM96B\_AD

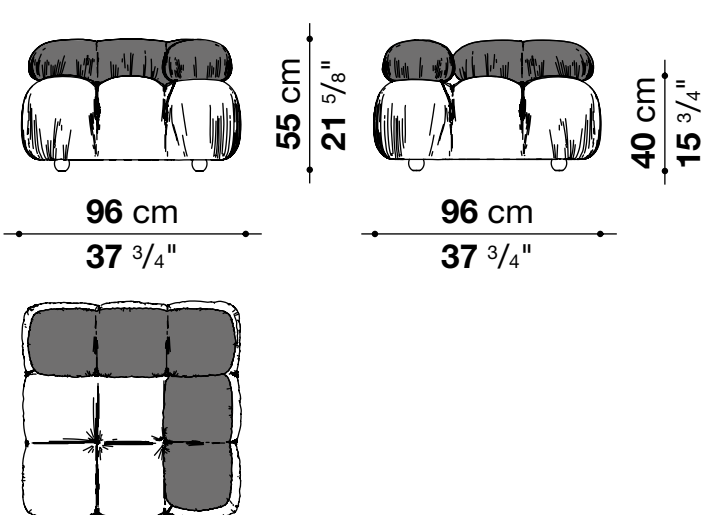

Terminal-Ottoman  
Terminali-Pouf

CM96TPS

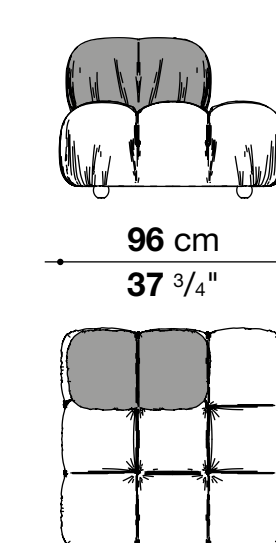

CM96TPD

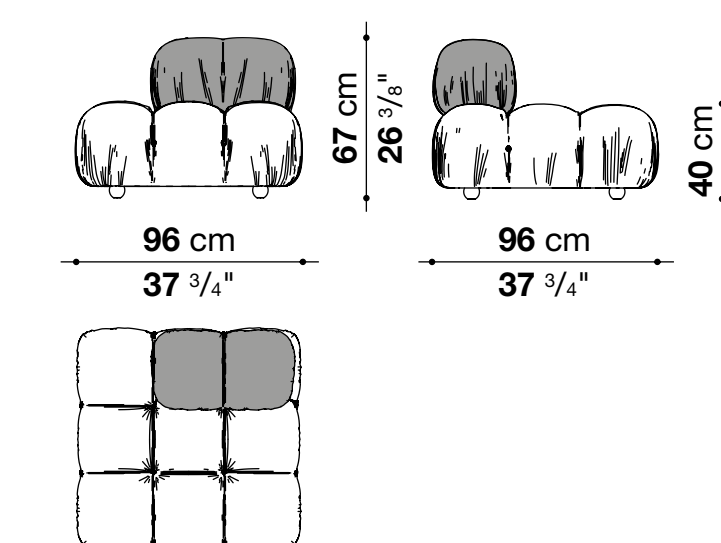

CM96B\_TPS

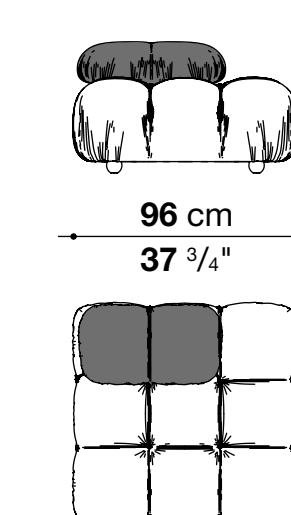

CM96B\_TPD

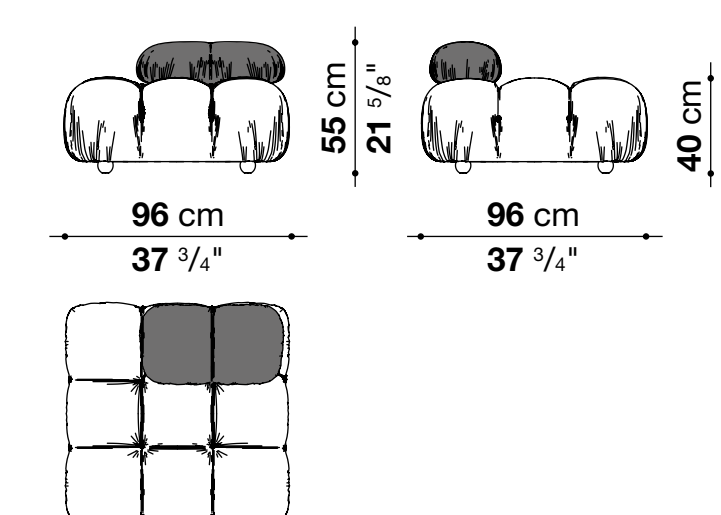

Ottoman  
Pouf

CM96PQ

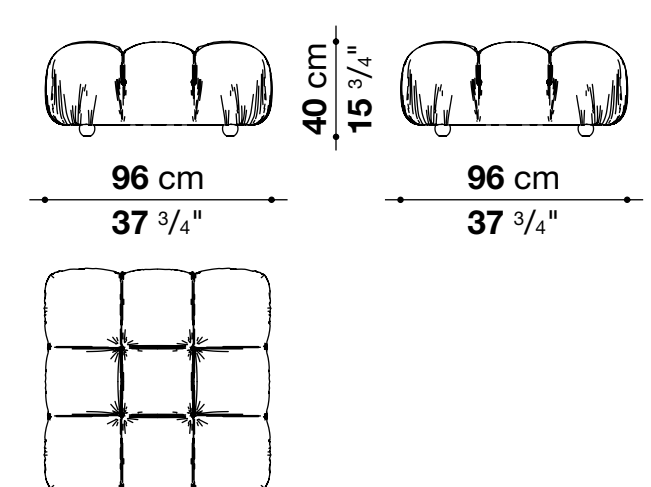

CM66P

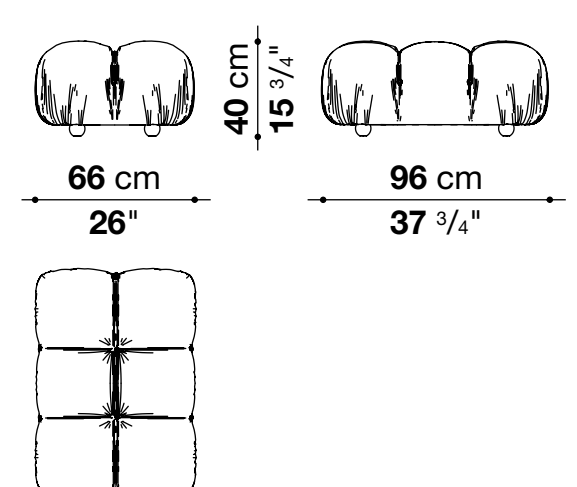

CM96P

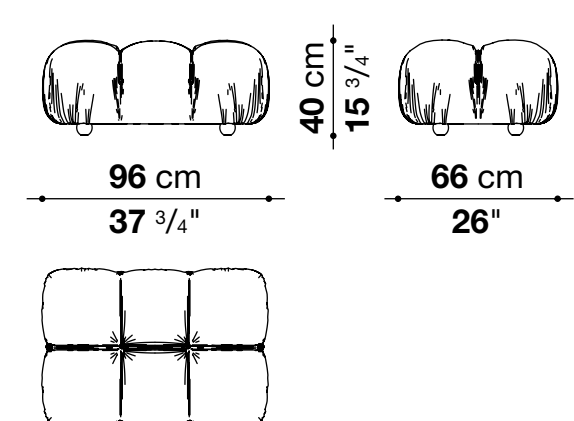

**Endless compositions**  
Infinite composizioni



**Endless compositions**  
Infinite composizioni





**Endless compositions**  
Infinite composizioni



**Endless compositions**  
Infinite composizioni



**Endless compositions**  
Infinite composizioni



**Endless compositions**  
Infinite composizioni



# **Gli Scacchi**

design Mario Bellini

The combinatorial nature of Camaleonda continues and is completed by Gli Scacchi, the chess pieces, a series of accessories designed by Mario Bellini to become extra table or seats.

La natura combinatoria di Camaleonda prosegue e si completa con Gli Scacchi, una serie di complementi disegnati da Mario Bellini per diventare tavolini o sedute extra.

# Gli Scacchi

The flexible nature of Camaleonda continues and is completed by Gli Scacchi, the chess pieces, a series of accessories designed by Mario Bellini to become additional tables or seats. The three pieces that make up the series are inspired by the game of chess, in particular the queen, the knight and the rook (hence the Italian names Regina, Cavallo, Torre), light and easy to move like on a chessboard. "They are among the most playful pieces of furniture I have ever designed", Bellini states, underlining the free and amusing spirit they bring to interiors.

**In the 1971's original version, Gli Scacchi represented a remarkable technical innovation as they were produced in self-skinning polyurethane foam, a solution which was initially used only by the automotive industry and introduced for**

**the first time in furniture. The 2020 reissue offers soft covers made of thick leather and calf hide with visible stitching.**

**The shape of the three elements elaborates on and develops the parallelepipedon, through structures made of soft polyurethane that perfectly synchronize with the dimensions of the Camaleonda. At the base there is an elegant metallic profile, an element that defines the geometry of the shape in contrast, with the softness of the object.**

I tre pezzi che compongono la serie sono ispirati al gioco degli scacchi, in particolare a Regina, Cavallo e Torre, leggeri e facili da spostare come su una scacchiera. "Sono tra gli arredi più giocosi che ho mai disegnato", dichiara Bellini, sottolineando lo spirito libero e divertito con il quale

vogliono popolare gli interni.

Nella versione originale del 1971 gli Scacchi hanno rappresentato una notevole innovazione tecnica con il loro rivestimento in poliuretano autopellante, una soluzione prima utilizzata soltanto per l'industria automobilistica e introdotta per la prima volta nell'arredo. Nella riedizione 2020 vengono proposti con morbidi rivestimenti in cuoio e cavallino con cuciture a vista.

La forma dei tre elementi elabora e sviluppa il parallelepipedo, per strutture in poliuretano morbido che per dimensioni si sincronizzano perfettamente con Camaleonda. Alla base troviamo un elegante profilo metallico perimetrale, elemento che sottolinea la geometria delle forme e dialoga per contrasto con la morbidezza dell'oggetto.





Gli Scacchi 1972













**Details**  
Dettagli



**Technical drawings**  
Disegni tecnici

**SA90\_RE**

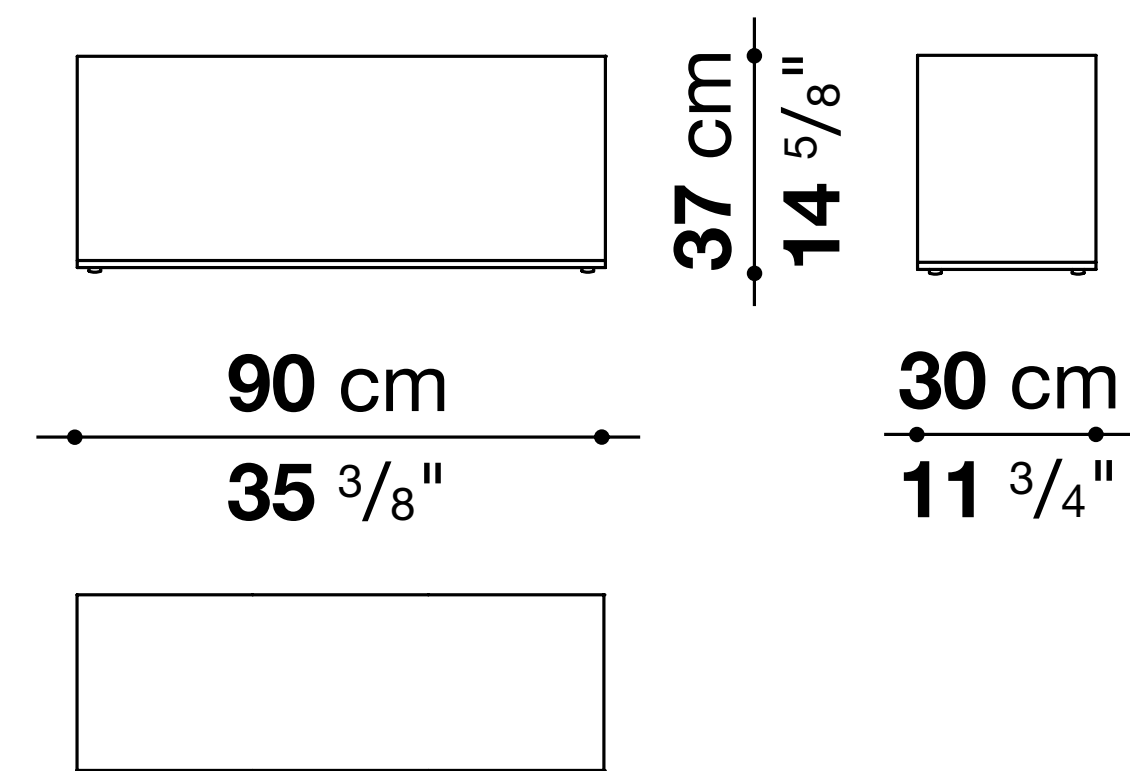

**SA90\_TO**

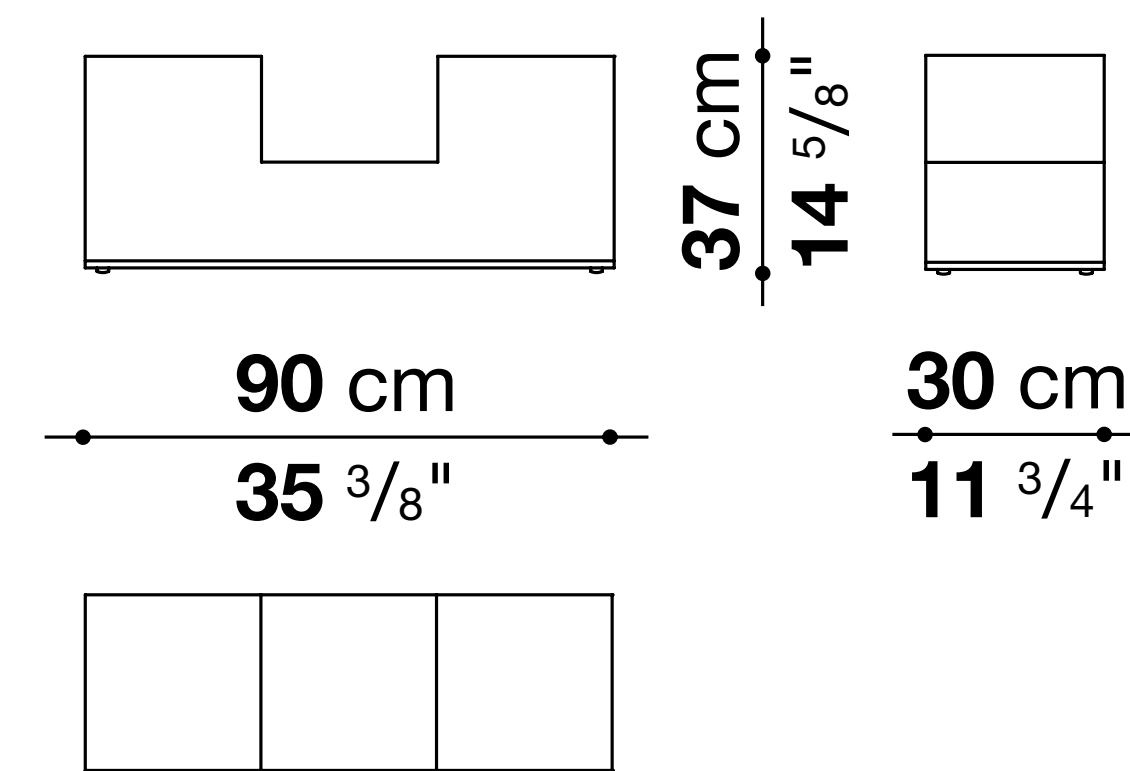

**SA90\_CA**

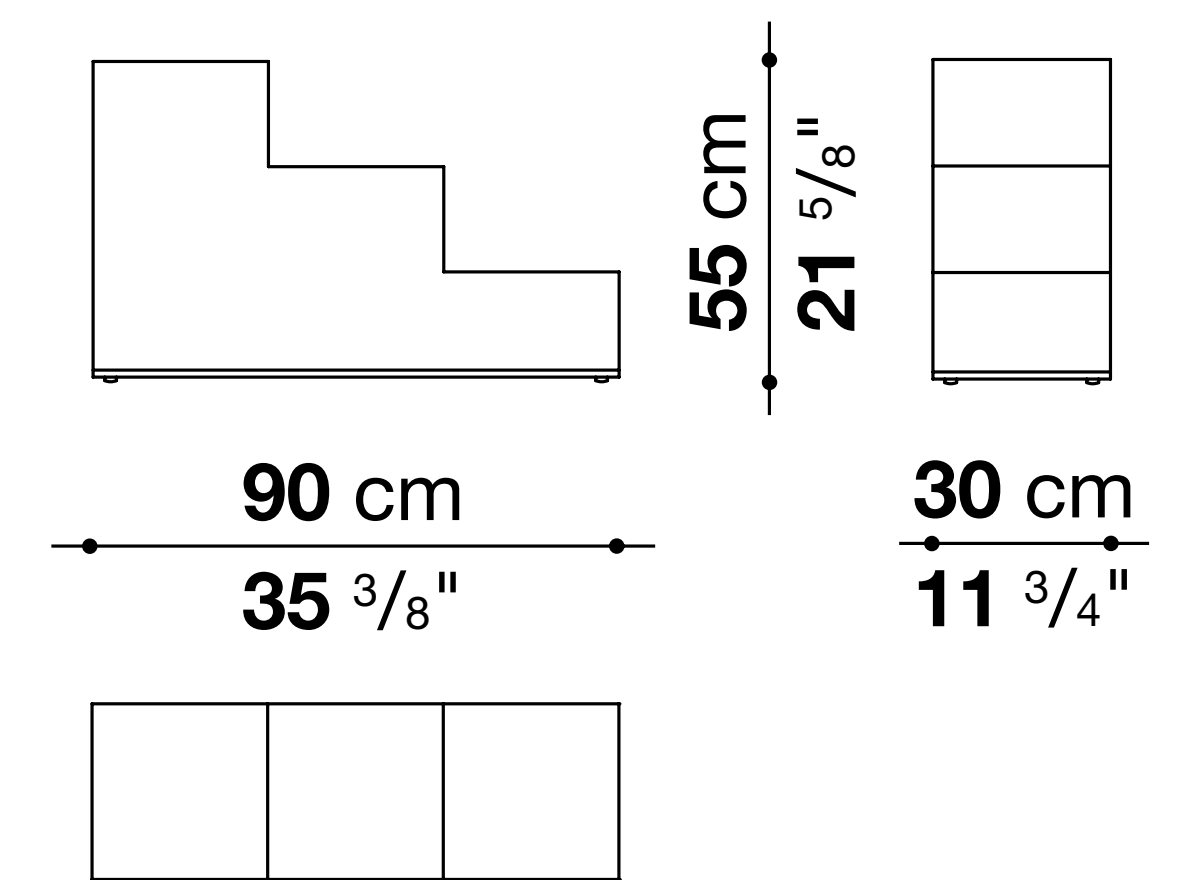

**Thick leather\_cuoio**



1121201  
ivory  
avorio

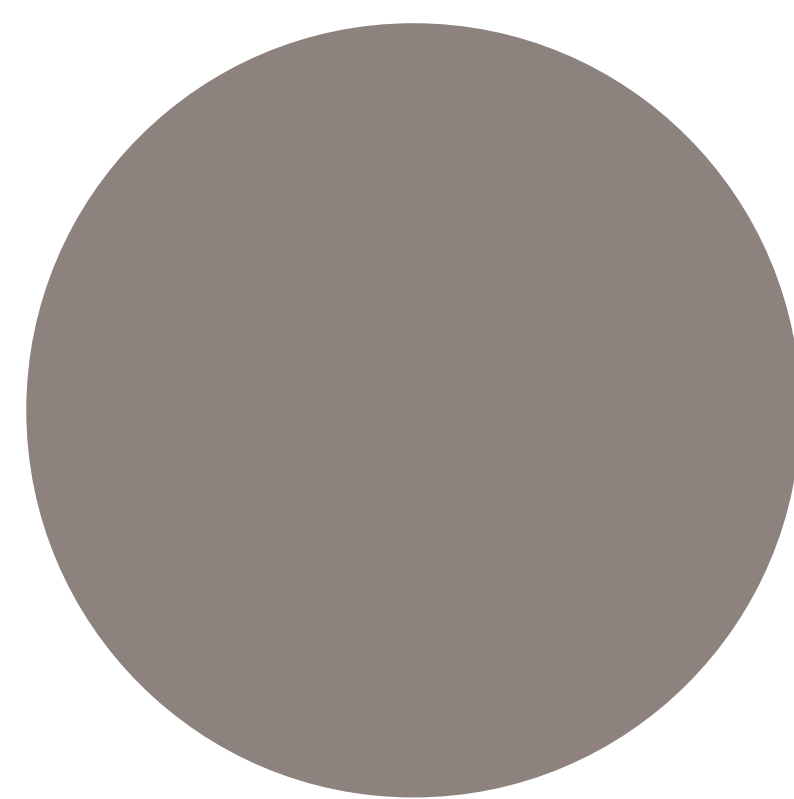

1121280  
tortora  
tortora

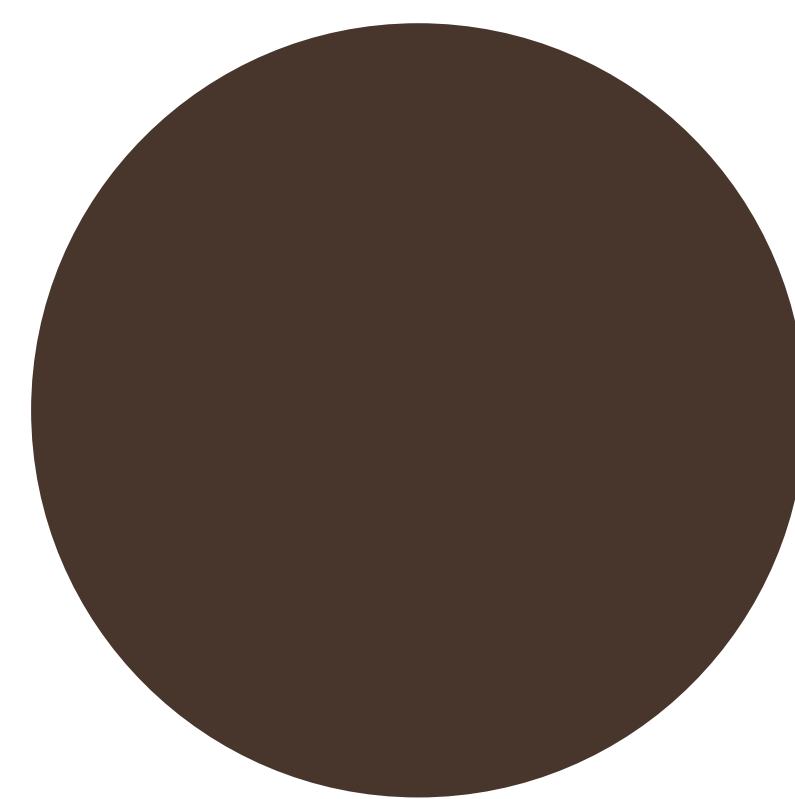

1121350  
dark brown  
testa di moro

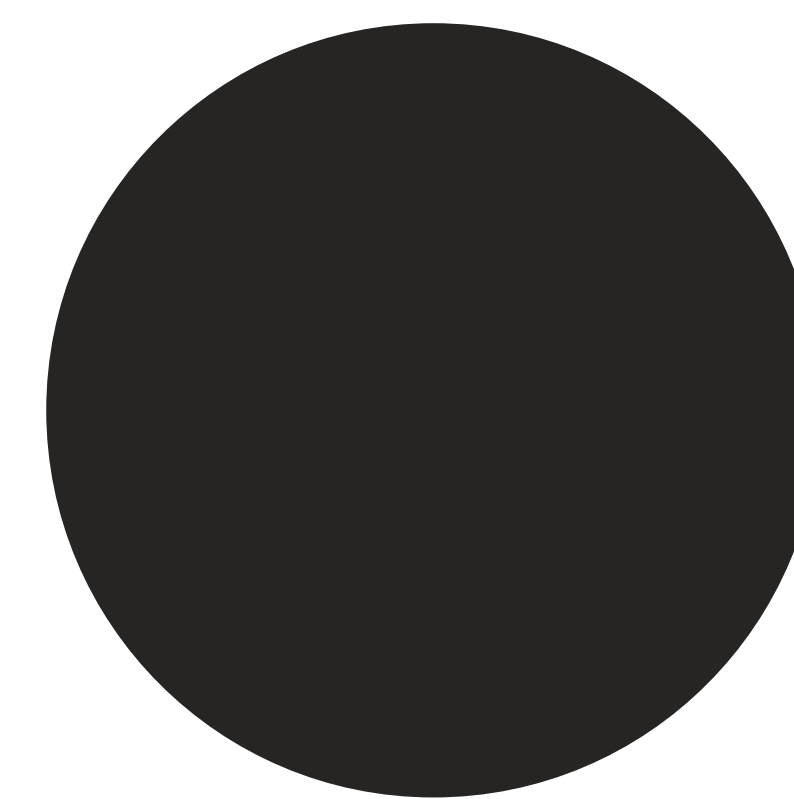

1121150  
black  
nero

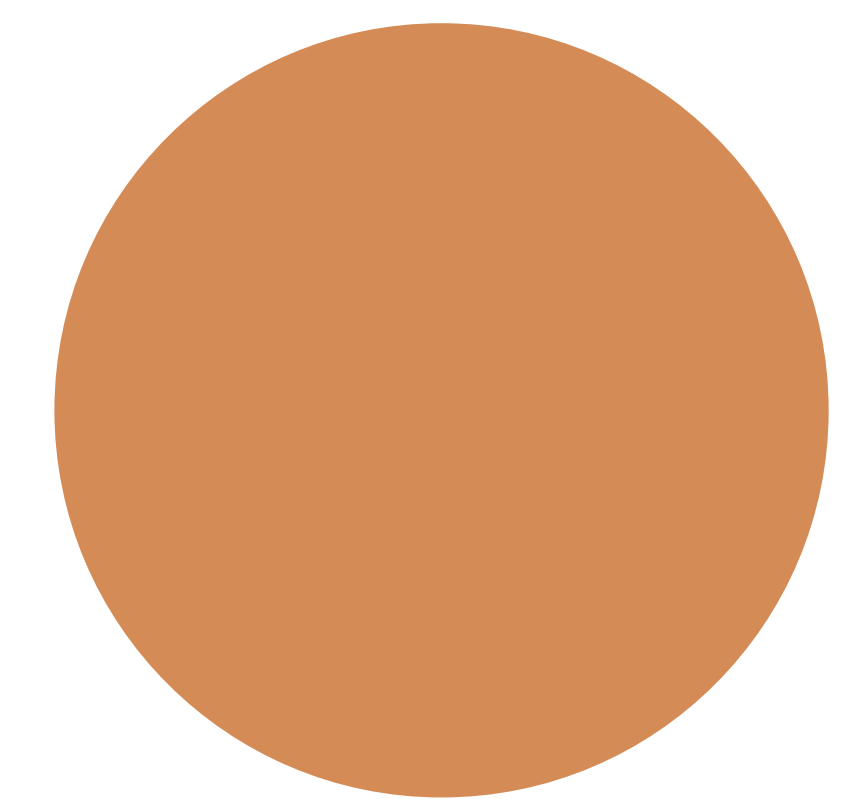

1121300  
natural  
naturale

**Kanu leather\_Pelle Kanu**



1122100  
white  
bianco



1122300  
brown  
marrone

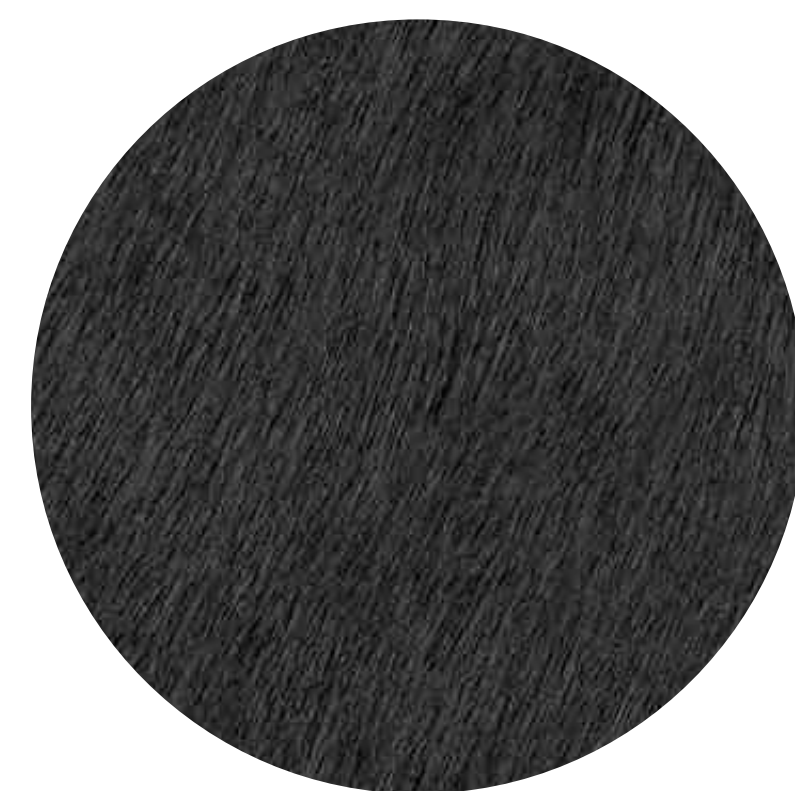

1122150  
black  
nero

**Base-frame finishing\_Finitura basamento**

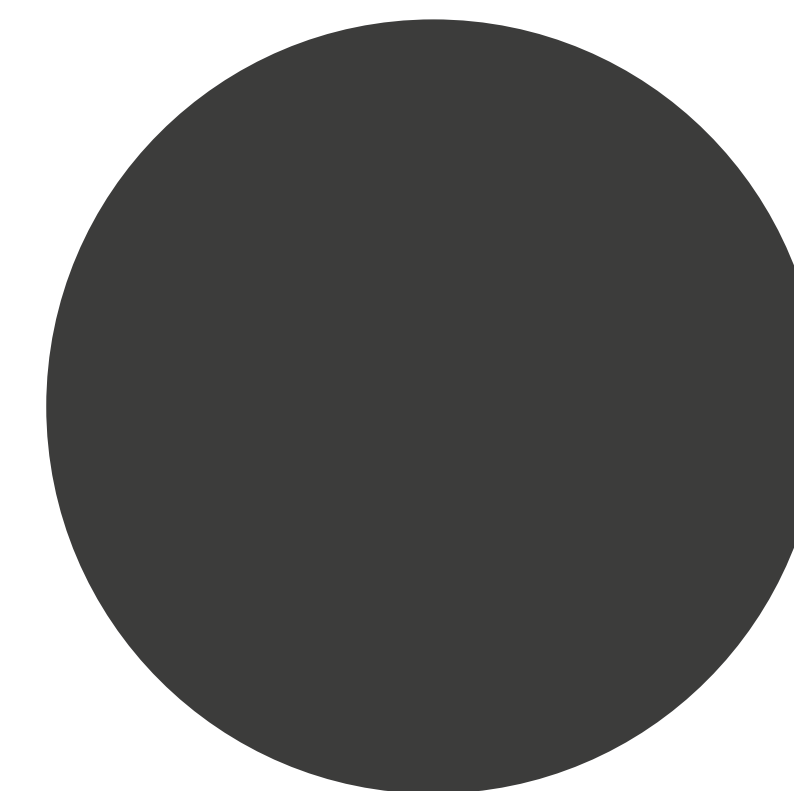

0170M  
painted black chrome  
verniciato cromato nero

# Camaleonda value proposition:

Key-words of Camaleonda 2020

## PRODUCT VALUES

**#designer:** Mario Bellini, a worldwide renown and celebrated designer

**#heritage:** a masterpiece of Italian design, 5 decades of history

**#innovation:** a “brand new” sofa concept in the 70s

**#iconic:** a powerful design language

## PRODUCT FEATURES

**#modular**

**#flexible**

**#sustainable**

**#comfortable**

**#prestigious:**

**#technology-manufacturing**

**#new fabric**

**#infinite looks** (38 fabric families, 4 leathers)



# Delivery terms:

Ex factory – starting from

**CAMALEONDA** (with existing covers): week 30\* July 20th (lead time 5 weeks)

**CAMALEONDA** (with existing covers): week 32\* August 3rd (lead time 5 weeks)

\* for orders received within week 25

**GLI SCACCHI:** week 30 (lead time 5 weeks)

End of tests for "Contract use"  
of **CAMALEONDA:** week 30

# Marketing tools:

To support your sales activity

**AVAILABLE ON MAY 22  
IN THE AGENTS AREA**

Video / Masterguide (with rooms prices) / Price list  
Window concept / Products presentation / List of covers

**FIRST HALF OF JUNE**



Camaleonda and  
Gli Scacchi configurator

New Enia fabric draft samples  
Agents: box size  
Dealers: small swatches delivered by couriers

**SEPTEMBER, EXACT DATE TBC**



New Enia fabric official samples

# Marketing and Communication Plan

The external launch will start from June 3rd 2020

## PRESS COVERAGE

- Italian print and digital press (from June issues).  
All the most relevant design magazine already confirmed the coverage.
- International digital press (from the first week of June).
- International print (from July issues).
- Print and digital advertising campaign: Fall 2020.

## SOCIAL MEDIA LAUNCH

(Instagram, FB, Pinterest, Twitter, LinkedIn)

Main Focus on Instagram + paid investments

- June 1st-14th | A storytelling based on iconic iconography.
- June 15th-end of month | A storytelling based on new materials.

# Marketing and Communication Plan

The external launch will start from June 3rd 2020

## DIGITAL PUSH

### Fuorisalone.it

The first digital Fuorisalone. From June, Camaleonda will have a monthly coverage with dedicated newsletter, social media posts, a dedicated webinar to A&D community and a video interview to be broadcast on fuorisalone.it TV channel.

### Architonic.com

On June 17th Camaleonda will have an entire day on the portal with banner, video box, newsletter, editorial contents.

### Archiproducts.com

From June, Camaleonda will have dedicated newsletter, editorial creativity and banners.

### Other digital coverage for the entire year

Chairish, Synchronia, Architizer, Archello, Stylepark, Interior Design, DesignBoom, Design Milk, Design Wanted, ArchDaily (from September), Contemporist.

### Corporate Website

Complete news, shootings and editorial inspiration.

# Marketing and Communication Plan

The external launch will start from June 3rd 2020

## SPECIALS

- June 5th: A dedicated podcast to Camaleonda, from our series THE COUCH, will be available on the B&B Italia official website, Apple Podcast, Spotify and Google Podcasts.
- Half of June an inspirational video that combines the history of Camaleonda and the main characteristics of the sofa will be pushed on YouTube and all the digital channels.
- Worldwide influencers as brand ambassador of Camaleonda (tbd).

## NEWSLETTER FROM HQ

- w/c May 18th: NL to the press only.
- June 8th: dedicated Newsletter to the A&D database with Camaleonda story and materials.
- Mid July: dedicated Newsletter to the A&D database with a reminder of Camaleonda with different pictures and main focus on the videos.
- Mid September: dedicated Newsletter to the A&D database with Camaleonda and New Products Launches.

**Thank you!**

**B&B**  
**ITALIA**