

Untitled

For this new sofa system, we wanted to reflect on the relationship between structure and comfort. Two dimensions that lie at the very heart of what a sofa is. The solid wood frame is intentionally expressed and left visible, defining the foundations of the piece. A subtle chamfer runs along its edges, allowing light to gently trace the structure and reveal the precision of its lines. The structure becomes more than a support; it becomes an integral part of the visual and tactile experience of the sofa. In contrast to this clear and essential framework, the cushions introduce softness and ease. They naturally embrace the structure, completing it rather than concealing it. Soft and welcoming, they invite the body to relax and settle in, creating a feeling of comfort and protection.

A place where one instinctively feels at ease and where time can quietly unfold. Conceived as a modular system, the sofa offers a wide range of compositions that adapt naturally to different spaces and ways of living. Each element was designed with everyday life in mind, allowing the sofa to evolve with its surroundings. Some modules subtly shift the traditional idea of the sofa, opening the possibility for new postures, new arrangements, and more relaxed ways of inhabiting it. The system was also conceived to move effortlessly between indoor and outdoor environments, maintaining the same architectural clarity and sense of comfort across different settings. An architecture for living, shaped by structure and softened by comfort.



Technical details

SOFAS

U260

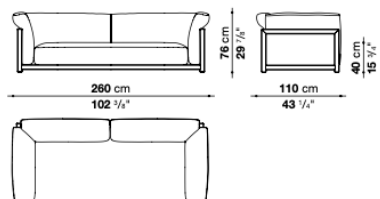

U220

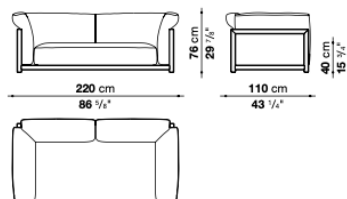

ARMCHAIR

U123

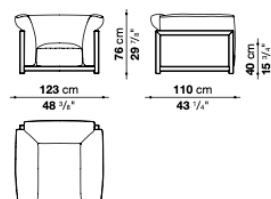

OTTOMAN

U100PQ

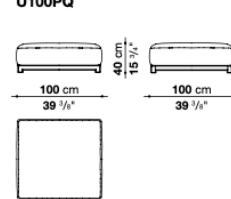

CENTRAL ELEMENT

U100C

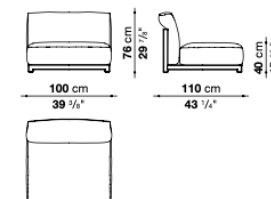

TERMINAL ELEMENT

U210TS

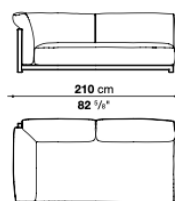

U210TD

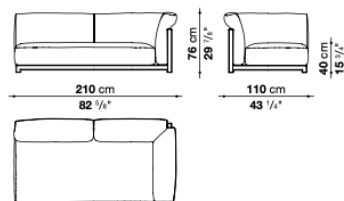

CORNER ELEMENT

U110AS

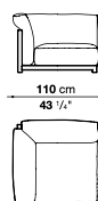

U110AD

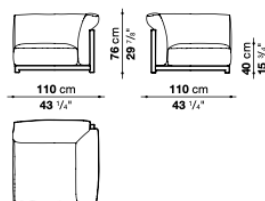

DAY BED

U147S

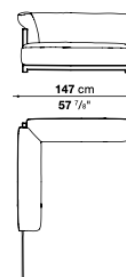

U147D

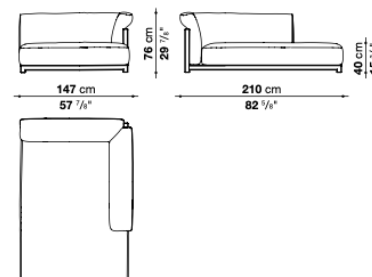

CHAISE LONGUE

U210LS

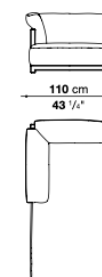

U210LD

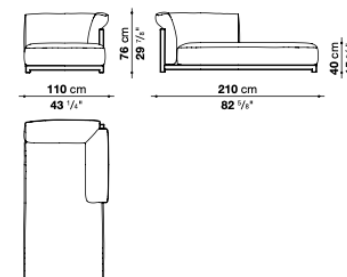

OTTOMAN - TERMINAL ELEMENT

U237TPS

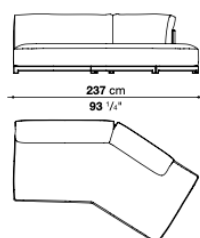

U237TPD

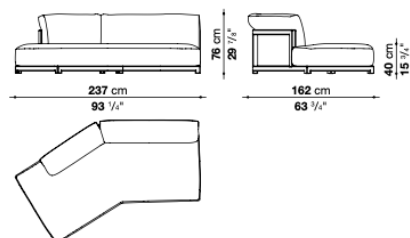

DORMEUSE

U247S

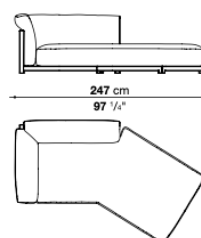

U247D

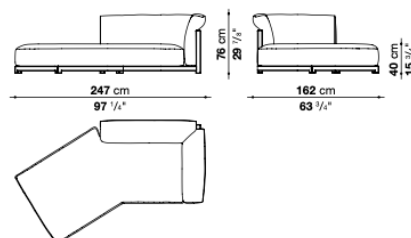





Chaise longue





033

Untitled - design Vincent Van Duysen

B&B
ITALIA

Compositions examples

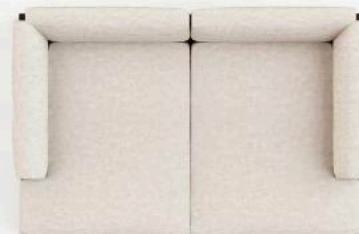

Compositions examples

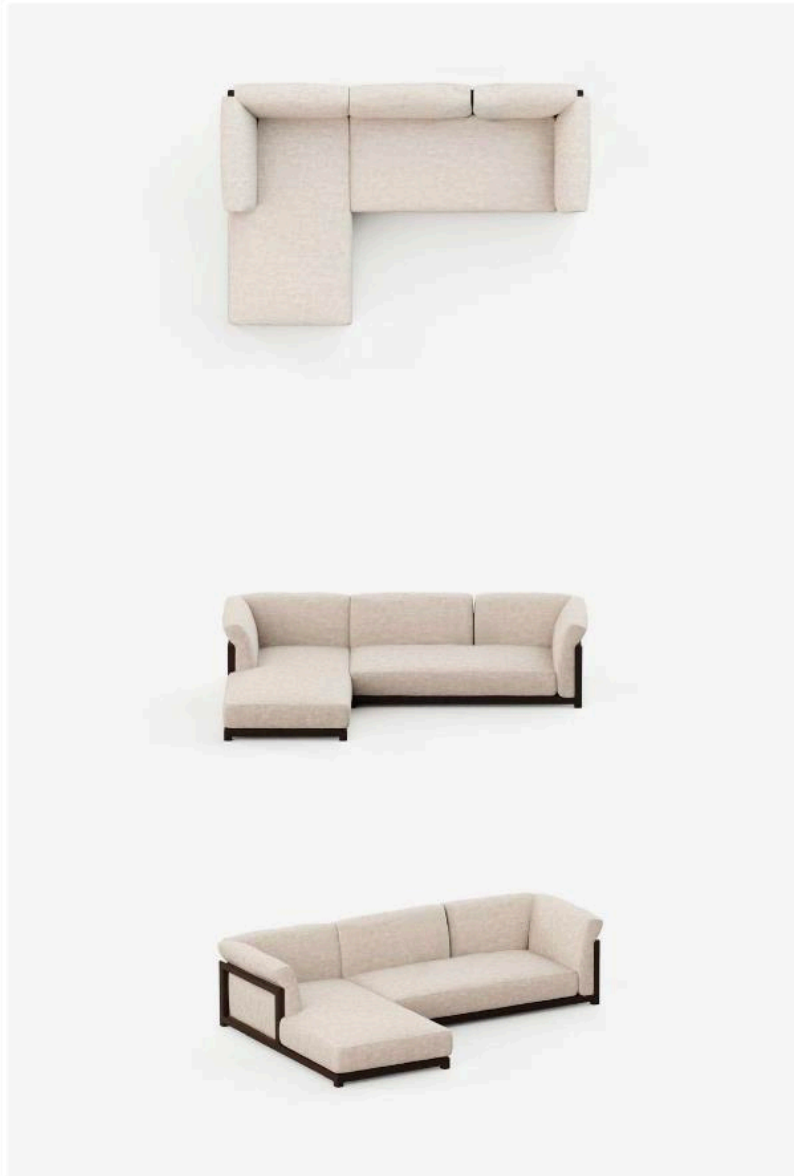

Compositions examples

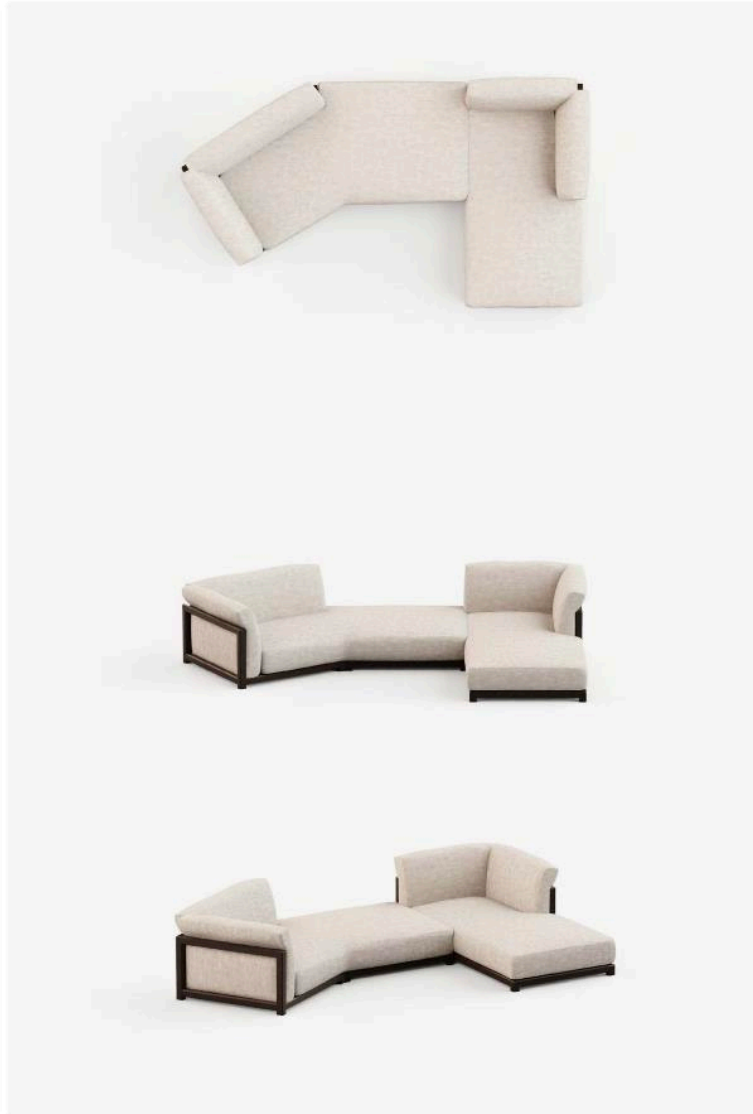

Technical details

FRAME



0374C
brushed light oak



0479S
brushed dark oak



0485N
ebony stained beech

COVER

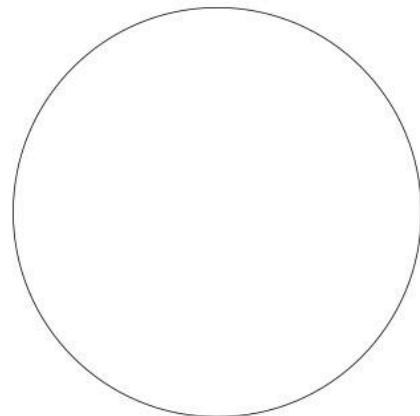

fabric / leather

Untitled Outdoor

Outdoor seating system

design Vincent Van Duysen



Technical details

SOFAS

OU260

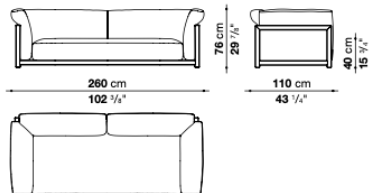

OU220

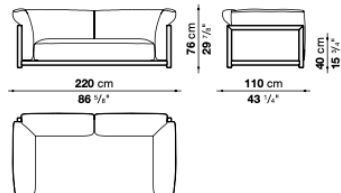

ARMCHAIR

OU123

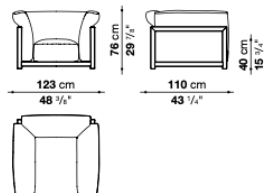

OTTOMAN

OU100PQ

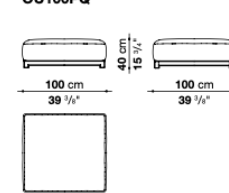

CENTRAL ELEMENT

OU100C

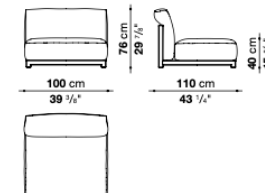

TERMINAL ELEMENT

OU210TS

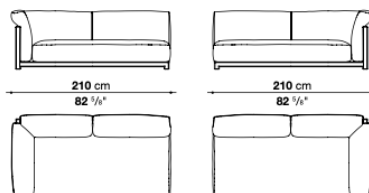

OU210TD

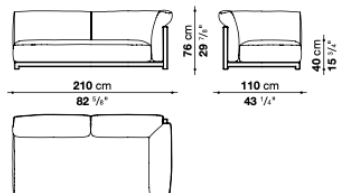

CORNER ELEMENT

OU110AS

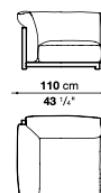

OU110AD

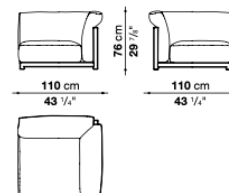

DAY BED

OU147S

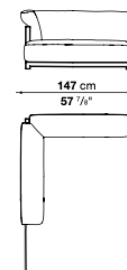

OU147D

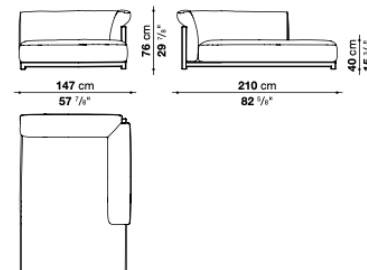

CHAISE LONGUE

OU210LS

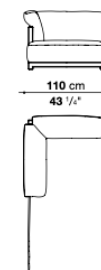

OU210LD

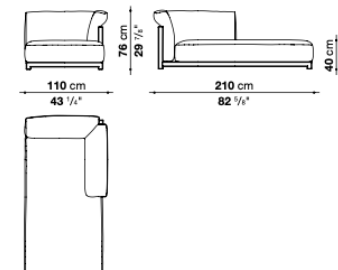

OTTOMAN - TERMINAL ELEMENT

OU237TPS

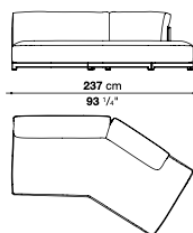

OU237TPD

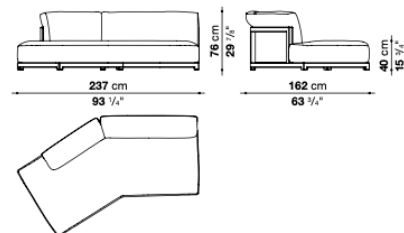

DORMEUSE

OU247S

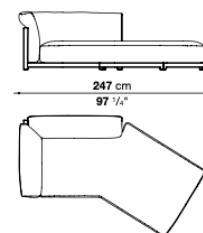

OU247D

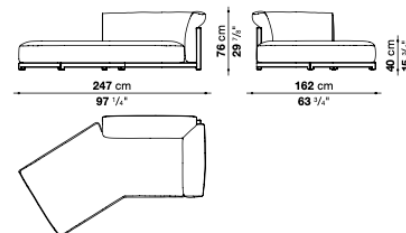

SUNBED

OU200L

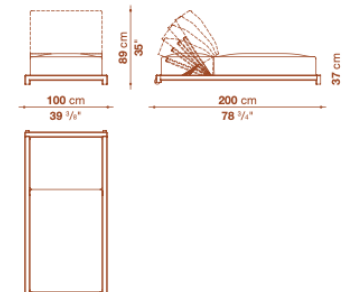

Moor (Indoor and covered Outdoor)

By its very nature, a chaise longue is a piece designed to follow the body, supporting it in a relaxed and extended posture while offering optimal comfort. As with the sofa, the structure plays a central role in the design. Here, it unfolds as a sensual and organic loop on which the rattan weaving is stretched, creating a continuous surface that gently receives the body. The woven rattan introduces warmth and tactility, while allowing the form to remain light and breathable. Particular attention was given to the design of the legs, which were

conceived so as not to interrupt the rhythm of this flowing gesture. Their discreet presence allows the continuity of the loop to remain clear and uninterrupted. Ergonomically conceived, comfort was an essential aspect of the project. The chaise longue naturally invites moments of rest and relaxation, accompanying the body with a sense of ease and support. Like the rest of the collection, the piece was designed to live both indoors and outdoors, maintaining the same balance between structure, material expression and comfort.





Moor (Indoor and covered Outdoor)



050

Moor - design Vincent Van Duysen



B&B
ITALIA

Technical details

CHAISE LONGUE

MR168L

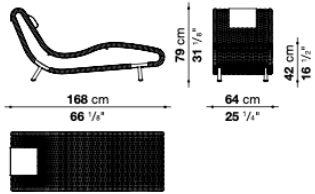

OMR168L

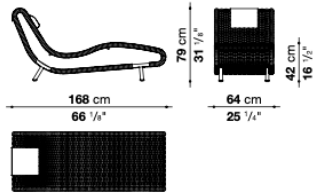

INTERLACING



0474N
natural rattan

SUPPORT FRAME / HEADREST COUNTERWEIGHT

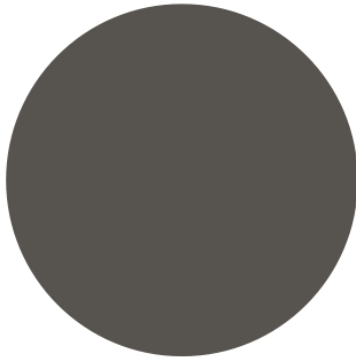

0174B
bronzed nickel painted

HEADREST COVER INDOOR

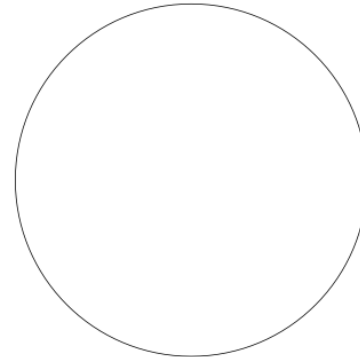

fabric / leather

HEADREST COVER OUTDOOR

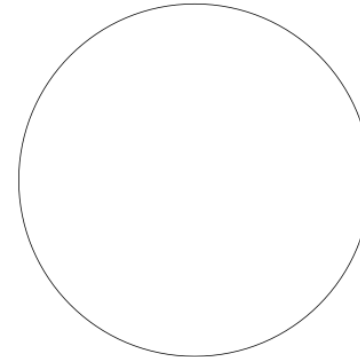

outdoor fabrics

Field

In the coffee tables accompanying the sofa system, the chamfered detail, first introduced in the sofa, becomes the defining gesture of the piece. Slightly curved, it reshapes the way we perceive the format of the table, subtly transforming a familiar typology. Light plays an essential role in this perception, gently tracing the changing geometry of the surface and revealing its delicate tension. It becomes a subtle way of rediscovering the table from every angle. A dynamic object on which the eye naturally lingers and moves.

The structure of the tables follows the same principle as the sofa's base, adopting its proportions and architectural clarity, creating a quiet dialogue between the different elements of the collection. The indoor versions are finished in lacquer, emphasizing the smoothness and depth of the surface, while the outdoor versions are crafted entirely in cement, giving the tables a more mineral and architectural presence. Once again, this reflects the intention to create a collection that naturally connects interior and exterior spaces.



Field



055

Field - design Vincent Van Duysen

B&B
ITALIA

Field



Field

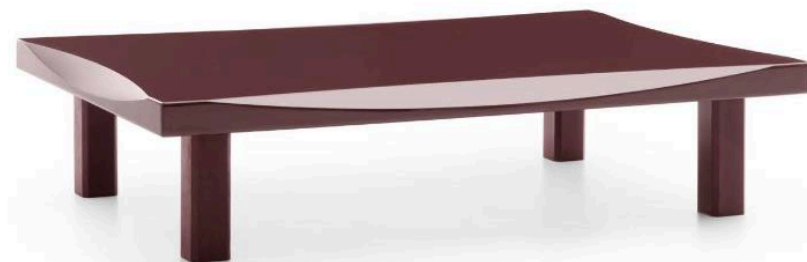

Technical details

LOW TABLES

TDF170

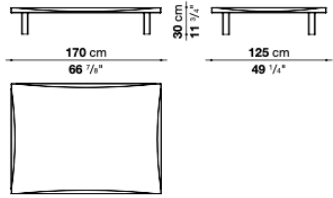

TDF125

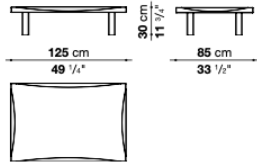

TOP / LEGS

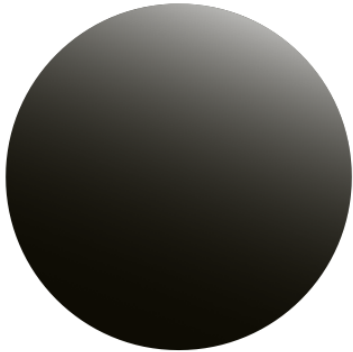

3764L
glossy black

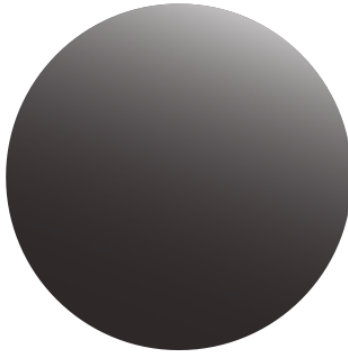

3750L
glossy coffee

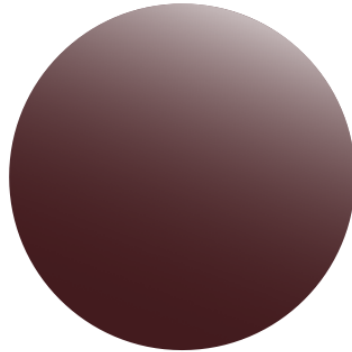

3751L
glossy plum

Field Outdoor



Technical details

LOW TABLES

OFD17T

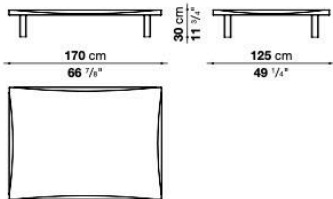

OFD12T

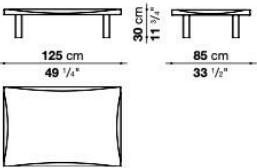

TOP / LEGS



0270B
antique white cement



0240G
greige cement



0324M
Sienna cement

Metric

Metric started as an exercise to design a lightweight chair in a linear language, using the slimmest possible sections of solid oak. It provides essential cross bracing to achieve the required structural strength. The outer frame is created with horizontal and vertical lines. The only curved element is the backrest; tilted at the required angle for maximum comfort. The seat is sloped backwards,

and this subtle inclination is accentuated - framed between two parallel beams that form the main structure. The collection includes a dining chair with compact proportions, a dining chair with armrests, a wider and lower armchair. All models are available entirely in wood or with a wooden frame and padded seat upholstered in thick leather.



Chairs



Armchairs





074

Metric - design Michael Anastassiades



B&B
ITALIA

Technical details

WOODEN CHAIR

SMR41_L

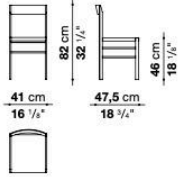

WOODEN CHAIR WITH THICK LEATHER SEAT

SMR41

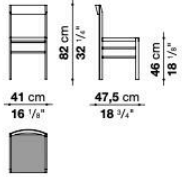

WOODEN CHAIR WITH ARMRESTS

SMR51B_L

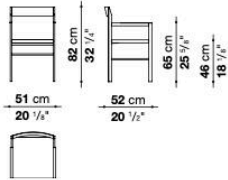

WOODEN CHAIR WITH ARMRESTS AND THICK LEATHER SEAT

SMR51B

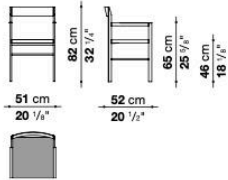

WOODEN ARMCHAIR

PMR58_L

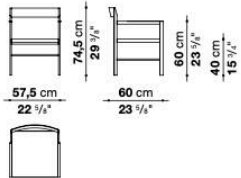

WOODEN ARMCHAIR WITH THICK LEATHER SEAT

PMR58

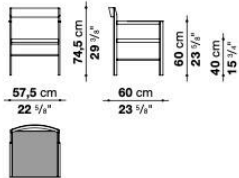

FRAME



0374C
brushed light oak



0313M
brushed moka oak



0381N
brushed black oak

SEAT

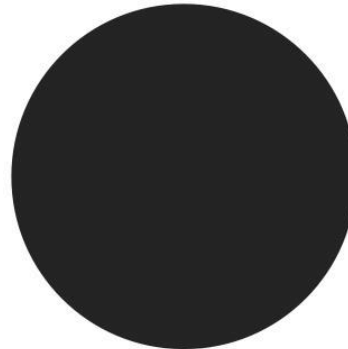

1121150
black thick leather

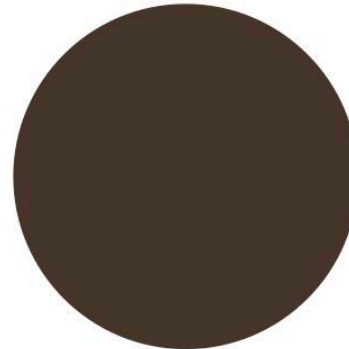

1121350
dark brown thick leather

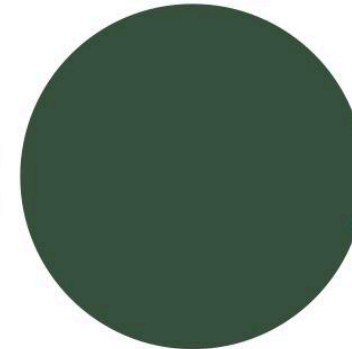

1121400
green thick leather

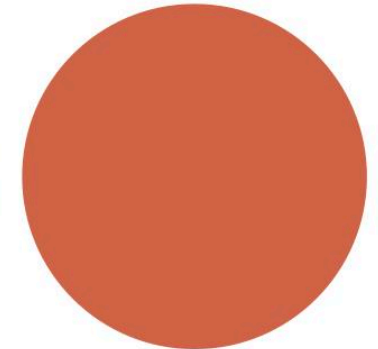

1121753
lobster thick leather

Abaco

With Abaco, Ronan Bouroullec has designed a project for B&B Italia that focuses on the theme of construction as a language: a table and chair system in which architecture, compositional precision, and the relationship between materials define the object's identity. At a time when many products tend to hide their construction logic, Abaco chooses to make it legible, entrusting its uniqueness to the clarity of its components, their proportions, and the way they connect. Wood, lacquer, concrete, smoked glass, and leather are treated not as overlapping finishes, but as structural elements that support and enhance one another. The armchair expresses this research through a simple yet balanced presence, in which the design of the legs

and the continuity between the seat, backrest, and armrest, covered in leather, create a measured balance between comfort and rigor. The table develops the same logic, with a structure articulated by the top, crosspieces, and legs, available in various material combinations: all-wood versions, solutions with lacquered or light grey concrete legs, and even a variant with a smoked glass top, which visually lightens the overall effect without sacrificing its architectural strength. The result is a family of objects in which the precision of the joints, the visibility of the parts, and the tactile quality of the materials transform function into an everyday experience: designed to inhabit space naturally, for sharing, working, reading, eating, and relaxing.





Abaco

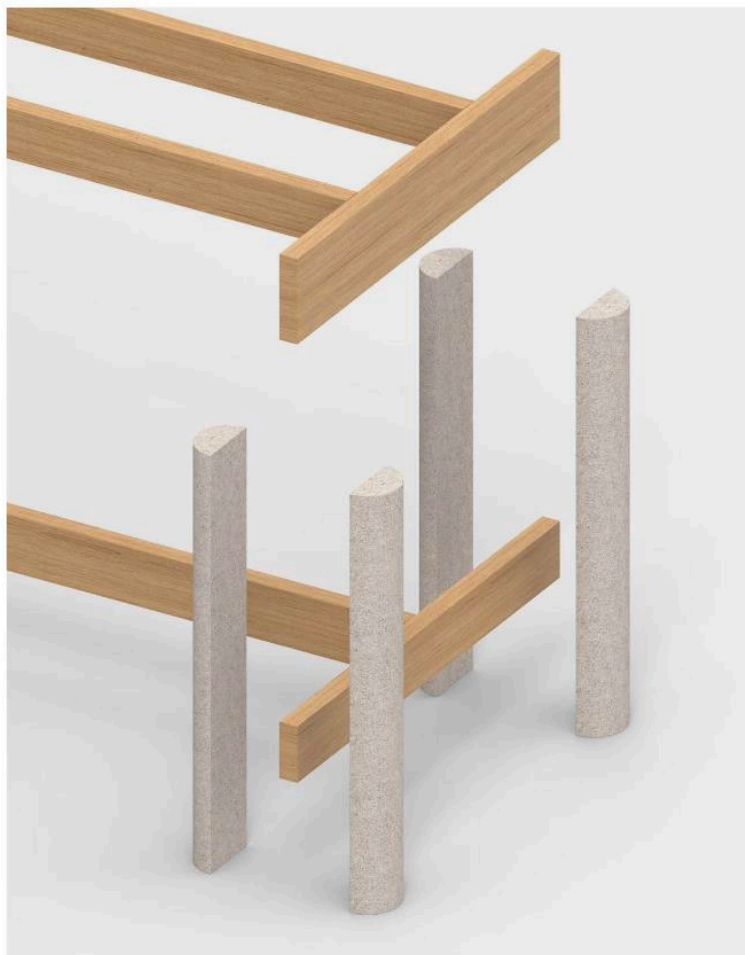

Abaco



Abaco





Abaco





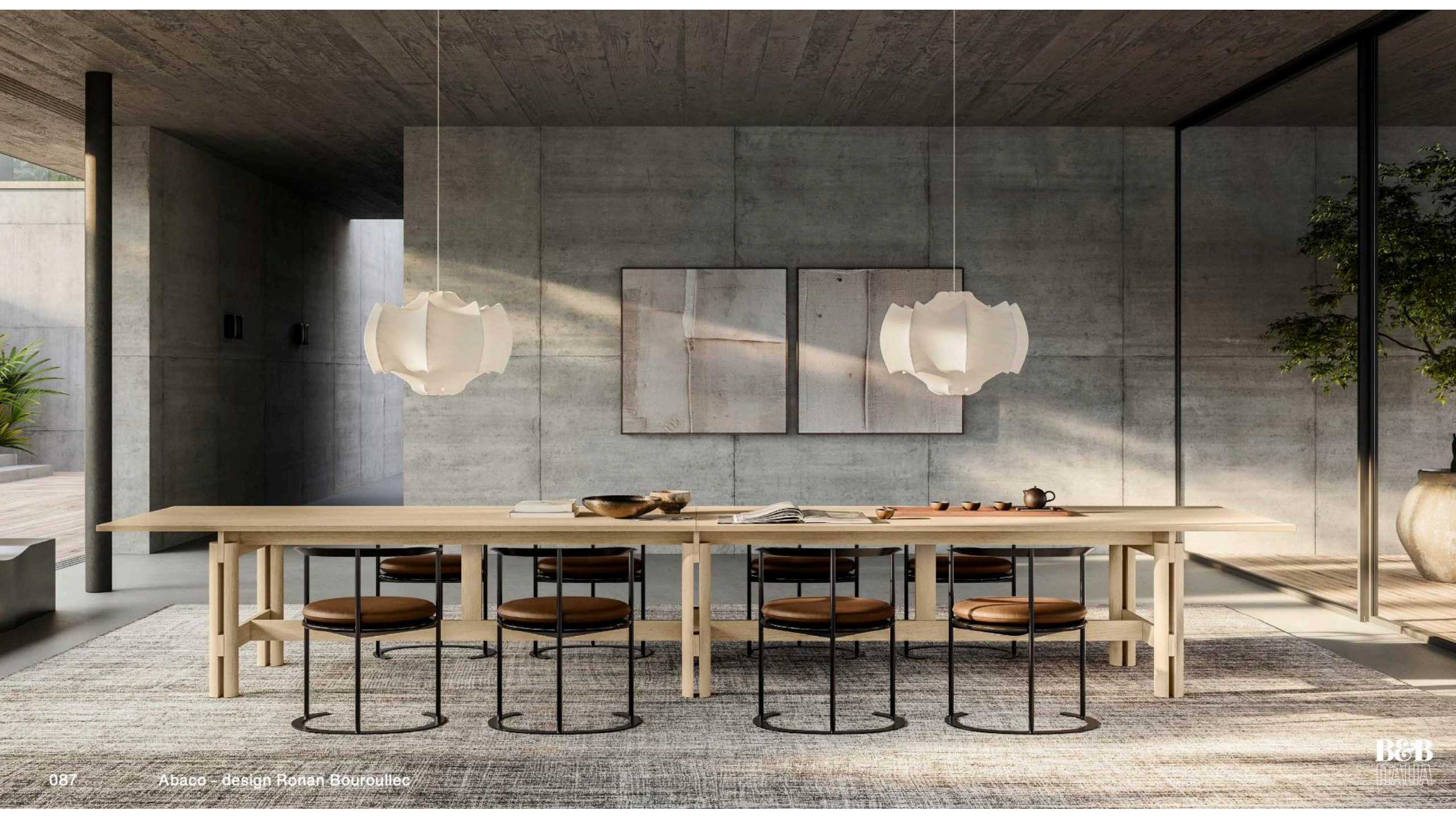

Technical details

TABLE 240 X 100 CM (6 SEATS)

TAB240

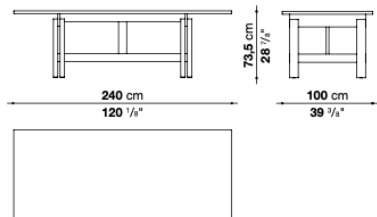

TAB240_B

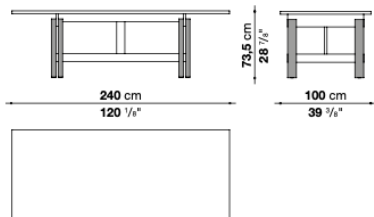

TAB240V

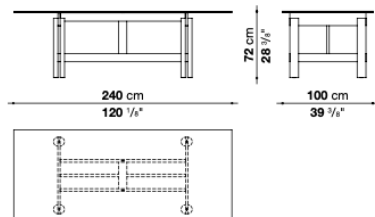

TAB240V_B

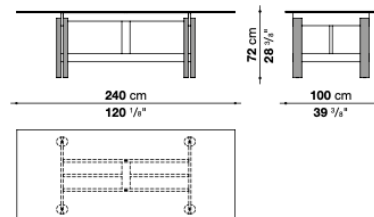
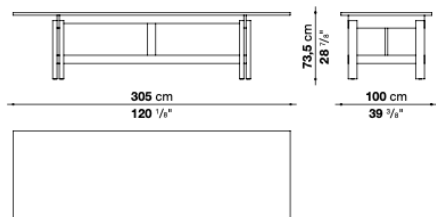
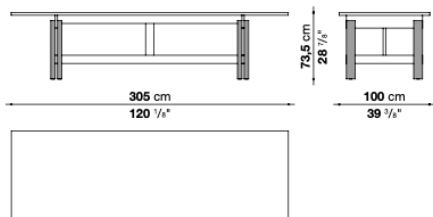

TABLE 305 X 100 CM (8 SEATS)

TAB305



TAB305_B



TAB305V

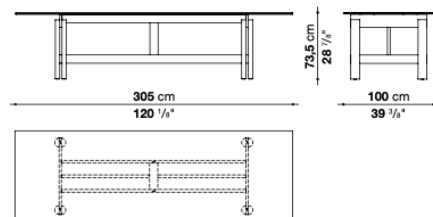

TAB305V_B

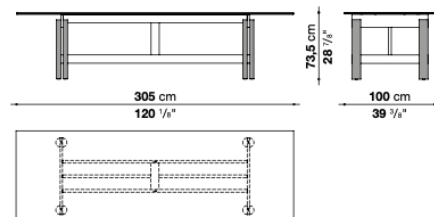
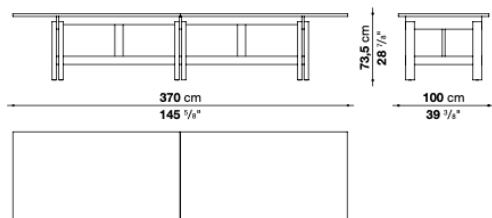

TABLE 370 X 100 CM (10 SEATS)

TAB370



TAB370_B

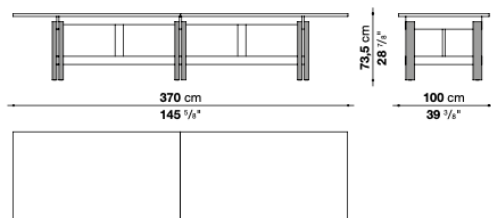
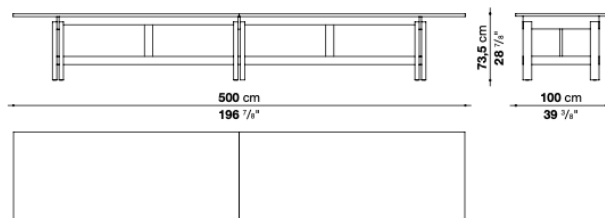
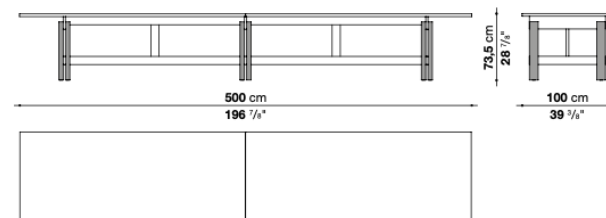

TABLE 500 X 100 CM (14 SEATS)

TAB500



TAB500_B



Technical details

TOP



0374C
brushed light oak



0356N
canaletto walnut



0381N
brushed black oak



0129F
smoky glass
(only for sizes 240 / 305 cm)

CROSSPIECES



0374C
brushed light oak



0356N
canaletto walnut



0381N
brushed black oak



0329C
brick red stained oak
(only for smoky glass top)

Technical details

WOOD LEGS



0374C
brushed light oak



0356N
canaletto walnut



0381N
brushed black oak

CEMENT LEGS

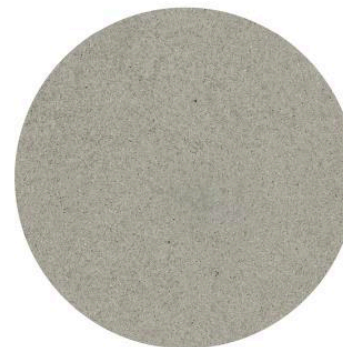

0220G
light grey cement

GLOSSY LACQUERED LEGS



9118L
chalk white



1322L
pearl white

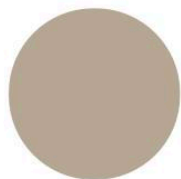

4516L
desert

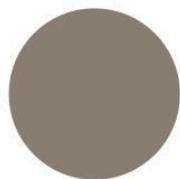

3738L
dove grey

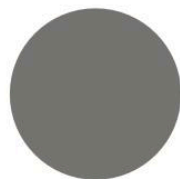

2557L
greige

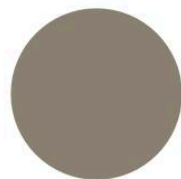

3748L
smoke grey

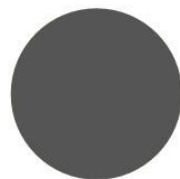

1340L
steel grey



9907L
anthracite



3750L
coffee



3764L
black

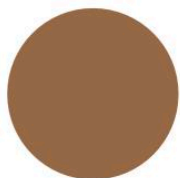

4232L
tobacco



3780L
olive



4835L
sage



1263L
mustard

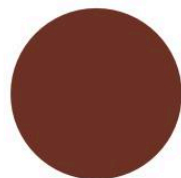

7850L
clay

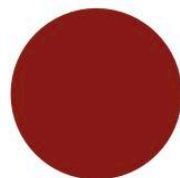

3755L
brick red



3751L
plum

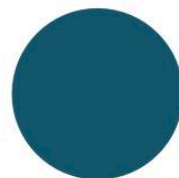

6020L
smoke blue

Technical details

OAK TOP

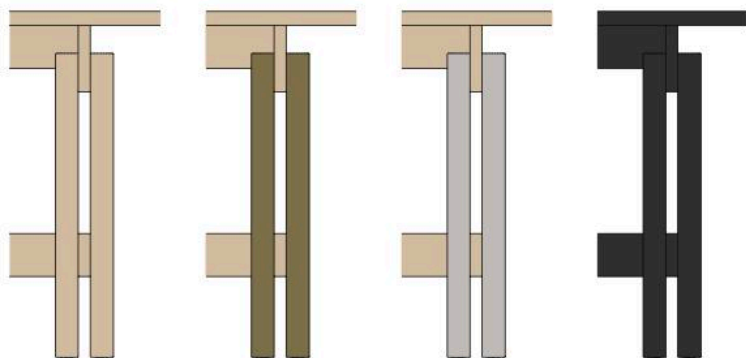

TOP



0374C
brushed light oak

0374C
brushed light oak

0374C
brushed light oak

0381N
brushed black oak

CROSSPIECES



0374C
brushed light oak

0374C
brushed light oak

0374C
brushed light oak

0381N
brushed black oak

LEGS



0374C
brushed light oak

glossy lacquered colors

0220G
light grey cement

0381N
brushed black oak

CANALETTO WALNUT TOP

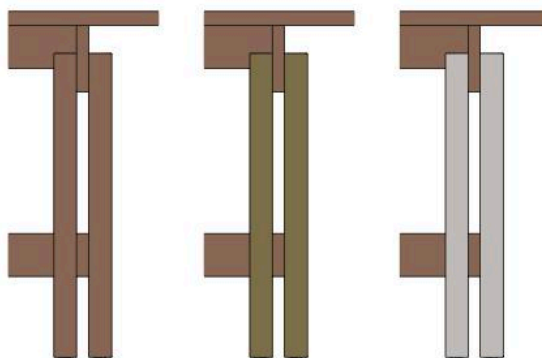

TOP



0356N
canaletto walnut

0356N
canaletto walnut

0356N
canaletto walnut

CROSSPIECES

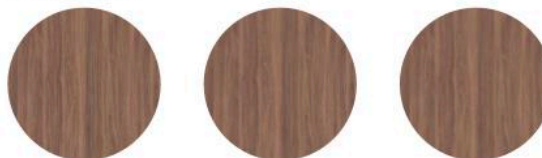

0356N
canaletto walnut

0356N
canaletto walnut

0356N
canaletto walnut

LEGS

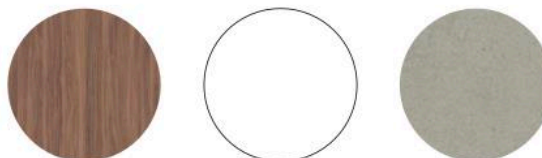

0356N
canaletto walnut

glossy lacquered colors

0220G
light grey cement

SMOKY GLASS TOP

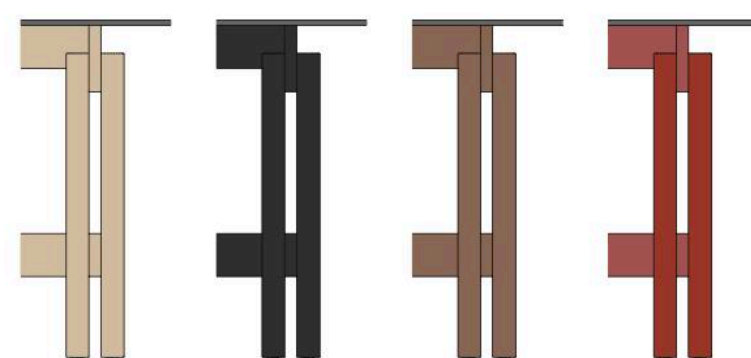

TOP

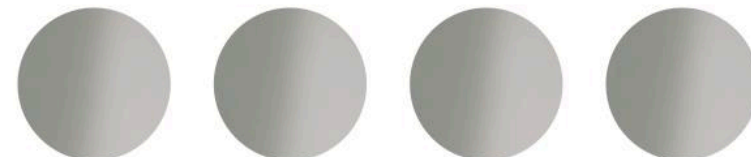

0129F
smoky glass
(only for sizes 240 / 305 cm)

0129F
smoky glass
(only for sizes 240 / 305 cm)

0129F
smoky glass
(only for sizes 240 / 305 cm)

0129F
smoky glass
(only for sizes 240 / 305 cm)

CROSSPIECES

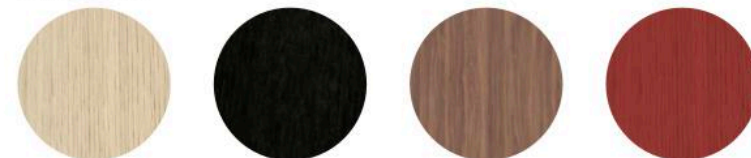

0374C
brushed light oak

0381N
brushed black oak

0356N
canaletto walnut

0329C
brick red stained oak

LEGS

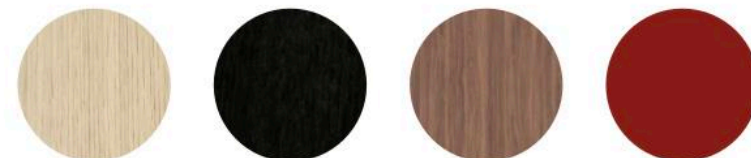

0374C
brushed light oak

0381N
brushed black oak

0356N
canaletto walnut

3755L
glossy brick red

Abaco

With Abaco, Ronan Bouroullec has designed a project for B&B Italia that focuses on the theme of construction as a language: a table and chair system in which architecture, compositional precision, and the relationship between materials define the object's identity. At a time when many products tend to hide their construction logic, Abaco chooses to make it legible, entrusting its uniqueness to the clarity of its components, their proportions, and the way they connect. Wood, lacquer, concrete, smoked glass, and leather are treated not as overlapping finishes, but as structural elements that support and enhance one another. The armchair expresses this research through a simple yet balanced presence, in which the design of the legs

and the continuity between the seat, backrest, and armrest, covered in leather, create a measured balance between comfort and rigor. The table develops the same logic, with a structure articulated by the top, crosspieces, and legs, available in various material combinations: all-wood versions, solutions with lacquered or light grey concrete legs, and even a variant with a smoked glass top, which visually lightens the overall effect without sacrificing its architectural strength. The result is a family of objects in which the precision of the joints, the visibility of the parts, and the tactile quality of the materials transform function into an everyday experience: designed to inhabit space naturally, for sharing, working, reading, eating, and relaxing.





Abaco - design Ronan Bouroullec



Abaco





099

Abaco - design Ronan Bouroullec

B&B
ITALIA

Technical details

ARMCHAIR

AB66P

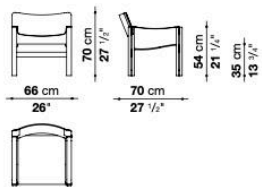

LEGS



0374C
brushed light oak



0356N
canaletto walnut

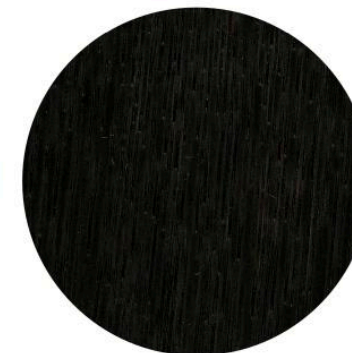

0381N
brushed black oak

SEAT / BACK / ARMRESTS

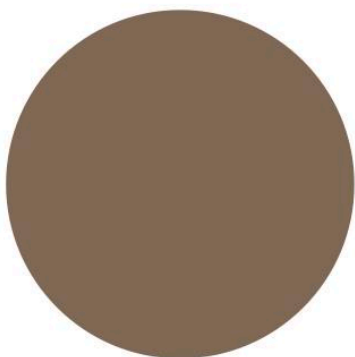

1121280
dove grey thick leather

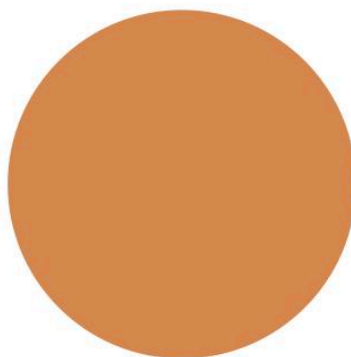

1121300
natural thick leather

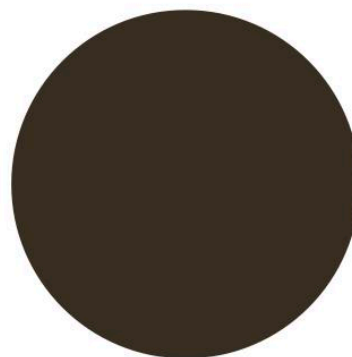

1121350
dark brown thick leather

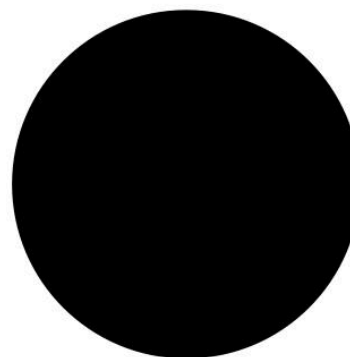

1121150
black thick leather

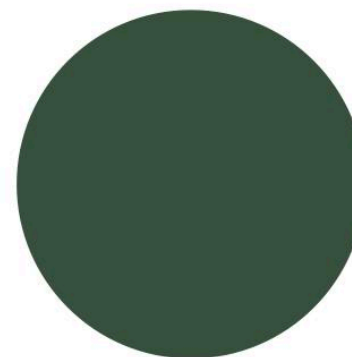

1121400
green thick leather

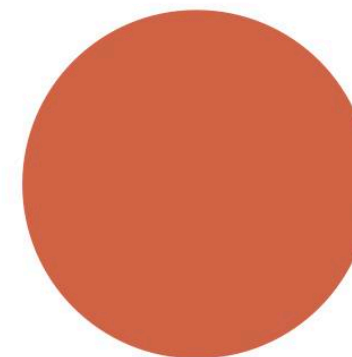

1121753
lobster thick leather

Nena

B&B Italia presents the reissue of Nena, the folding armchair designed by Richard Sapper in 1984, a design that exemplifies lightness, strength, and flexibility. A central figure in international design in the late twentieth century, Sapper built his research around technically complex problems, creating objects that have become part of design history—from the TS 502 radio and the Grillo telephone to the Tizio lamp and the first IBM ThinkPad—and garnering numerous awards, including the Compasso d'Oro Lifetime Achievement Award in 2014. In this journey, Nena occupies a particularly significant position because it condenses into a simple,

mobile form the same tension between technical invention, everyday use, and a precise construction that made Sapper's work so influential and still relevant today. The result of advanced experimental research on materials, Nena introduces a tubular aluminium frame into the seat: a choice that lends the object mechanical solidity and elasticity. The project is completed by the lightweight backrest and seat, the cushion upholstered in fabric or leather and the articulated joints in die-cast aluminium, which allow Nena to fold elegantly, confirming even today the radical modernity of Sapper's vision.



Nena



Nena







Technical details

FOLDING ARMCHAIR

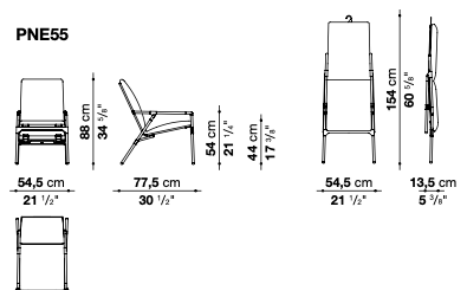

SUPPORT FRAME / EXTRACTABLE ELEMENT

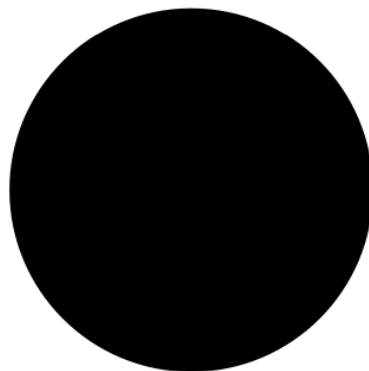

0195N
black semi-glossy painted

SEAT / BACK PANEL

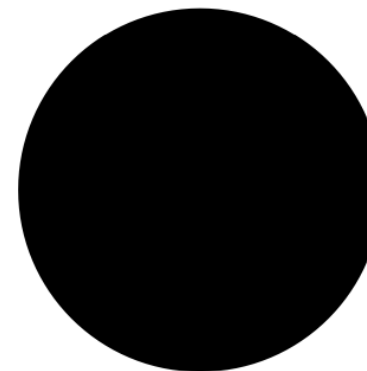

3764E
satin black



0505M
honey stained Okumé

COVER

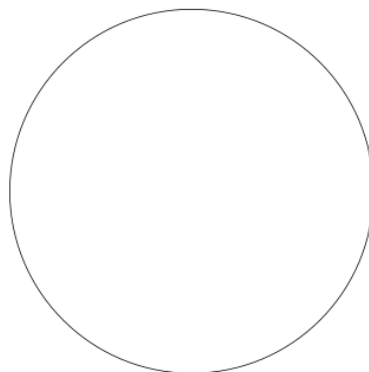

fabric / leather

Alvar

Alvar is a seating collection born from a reflection on wood, not only as a construction material but as part of a tradition. The project includes an armchair in two versions, one with a low back, the other with a high back, united by a simple language and a construction that connects memory and innovation. The frame is made of oak, left with a matte finish to express a sober material quality, with a nod to a Nordic sensibility. The design integrates elements from Italian tradition, such as the curved armrest of the Chiavarina chair, reinterpreted through a contemporary process. The woodworking, once entirely

manual, is now made possible by advanced technologies that allow for precision and formal coherence. A defining element of the collection is the backrest, made of woven cork cord. The intentionally sparse weave introduces a structural tension that contributes to comfort and visual lightness. The armchairs feature a slatted frame with a padded seat. Alvar thus strikes a balance between tradition and modernity, where the design is never a direct reference, but a reinterpretation. A work on memory that is translated into a contemporary object, designed to last and accompany daily use.



Armchair with high back



Armchair with low back





Technical details

ARMCHAIR WITH HIGH BACK

AV67PA

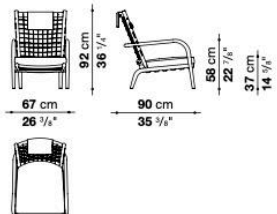

ARMCHAIR WITH LOW BACK

AV67PB

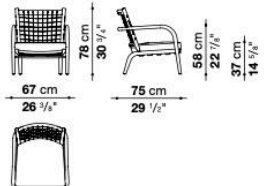

FRAME - BACK

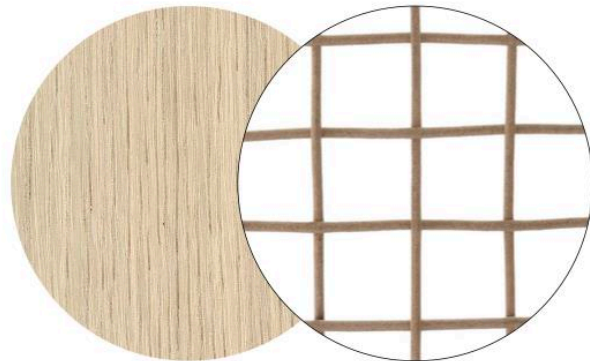

0374C

brushed light oak

0232S

light cork rope interlacing

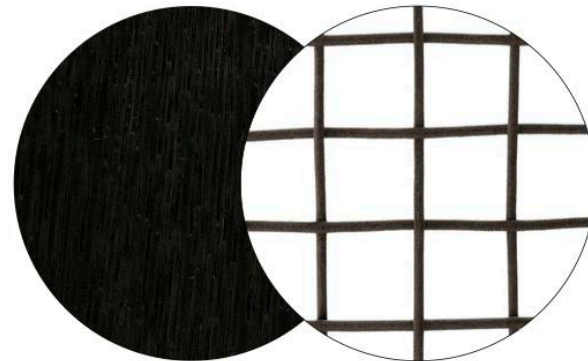

0381N

brushed black oak

0526C

dark cork rope interlacing

HEADREST COVER

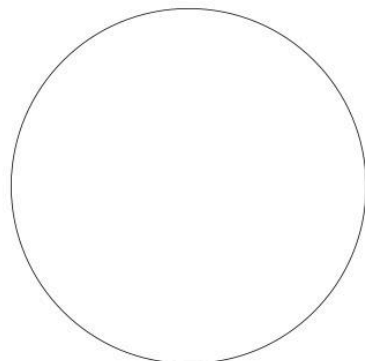

fabric / leather

Super Frame

Outdoor seating system and small tables

design Jasper Morrison

Super Frame

Super Frame is a family of outdoor armchairs, sofas, and coffee tables where the lightness of aluminium and the naturalness of rattan combine to create a balance of comfort, elegance, and formal clarity. The design stands out for its wide, curved armrest, a continuous line that defines the character of the entire collection while simultaneously naturally supporting the rest of the structure. The measured proportions and essential design contribute to creating a welcoming and relaxed atmosphere, in keeping with the

idea of an outdoor experience experienced with the same quality and intensity as a domestic space. In Jasper Morrison's vision, Super Frame was born from this very research: an object capable of being at once clear, pleasant, and atmospheric. The reference to the early era of modernism is found in the tubular structure, here reinterpreted with a contemporary sensibility to create a collection with a sober, recognizable, and timeless character.



Armchair



Armchair with cushions



Two seater sofa



Technical details

SOFAS

SU150

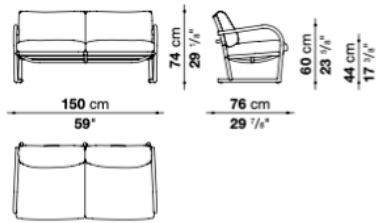

SU223

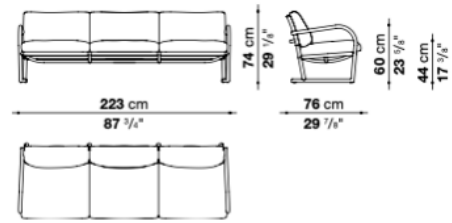

ARMCHAIR WITH CUSHIONS

SU66

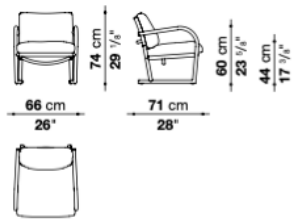

ARMCHAIR

SU61

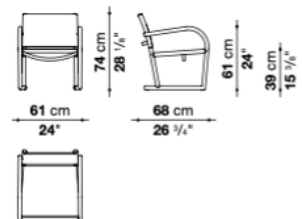

Technical details

FRAME



0261B
cream white painted

SEAT / BACK SUPPORT



2572207
Laguna rope

CUSHIONS COVER

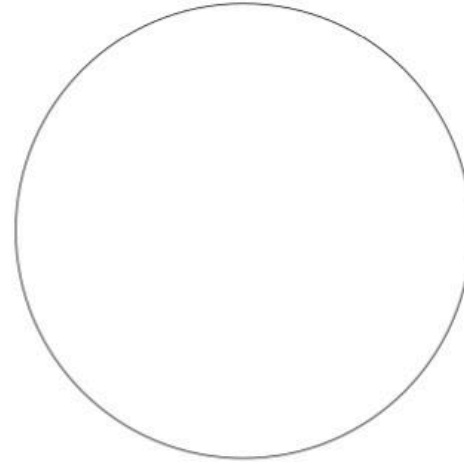

fabric

Small table



Technical details

LOW TABLE Ø 115 CM

TSU115R

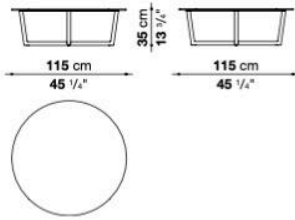

SMALL TABLE Ø 90 CM

TSU90R

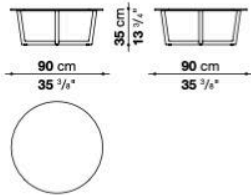

SMALL TABLE Ø 70 CM

TSU70R

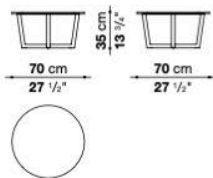

FRAME

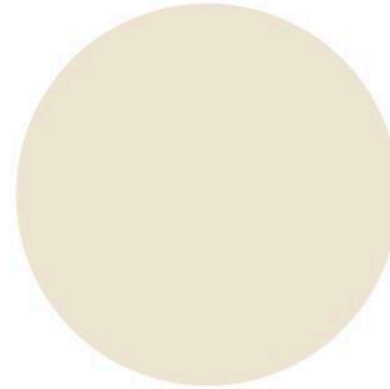

0261B
cream white painted

TOP



0284G
greige porcelain stoneware

Super Frame Rattan

Covered outdoor seating system and small tables

design Jasper Morrison

Armchair with cushions



Technical details

SOFA

RS150

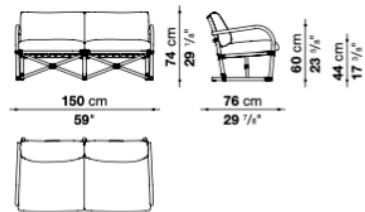

ARMCHAIR WITH CUSHIONS

RS66

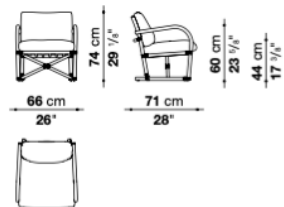

ARMCHAIR

RS61

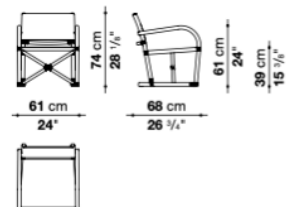

Technical details

FRAME



0826R
natural rattan

SEAT / BACK SUPPORT



2572207
Laguna rope

CUSHIONS COVER

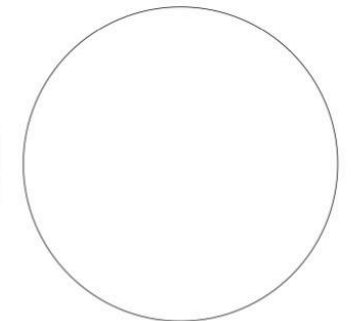

fabric

Catilina

The products designed by Luigi Caccia Dominioni for Azucena are now part of the B&B Italia catalogue. To mark this occasion, the celebrated Catilina chair is being reissued in a glossy finish and accompanied by a new series of cushions in special limited-edition fabrics. The request for a new fabric for the cushions of the Catilina chair was interpreted by the Haus Nuller textile studio, starting from a reflection on Luigi Caccia Dominioni's methodology. An analysis of his work, spanning architecture and design, leads to the identification of line as a constant. Not an applied graphic element, but a constructive principle capable of organizing form within a coherent system of relationships. From this interpretation, line emerges as the central element of the project, not as a sign, but as a generative device capable of crossing different

disciplines. On this basis, Haus Nuller has summoned Willem Cole, an artist whose work is grounded in a minimalist visual language, built on the use of three primary colours—red, yellow, and blue—organized along lines with modular and structural relationships. Textiles thus become the locus of a methodological rather than formal translation. Haus Nuller interprets the internal logic of Cole's designs: line, rhythm, proportion, and chromatic relationships are taken as operational principles and transferred to the language of weaving, where variations in yarn, density, and structure generate depth and material articulation. The richness of textile and chromatic solutions achieved requires sophisticated artisanal production with hand-spun fabrics, reproducible only in small quantities and offered by B&B Italia in a limited annual series.



Catilina



Technical details

HIGH ARMCHAIR

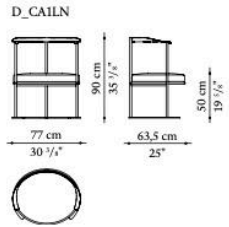

LOW ARMCHAIR

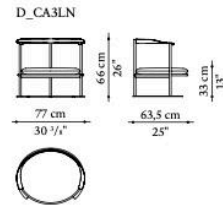

CHAIR

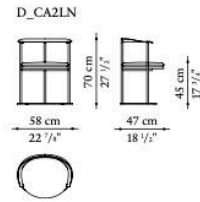

FRAME

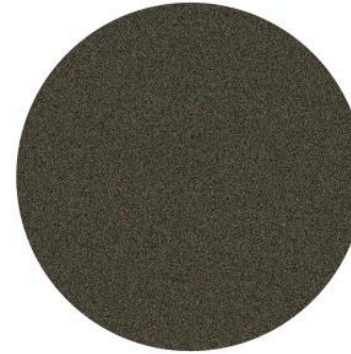

0799M
metallic grey finish

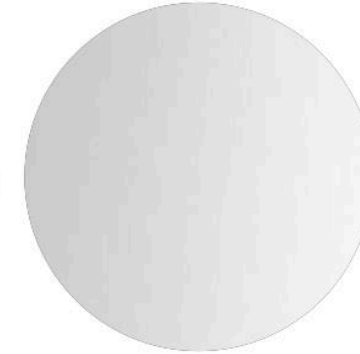

0600C
chromed finish

SEAT CUSHION COVER

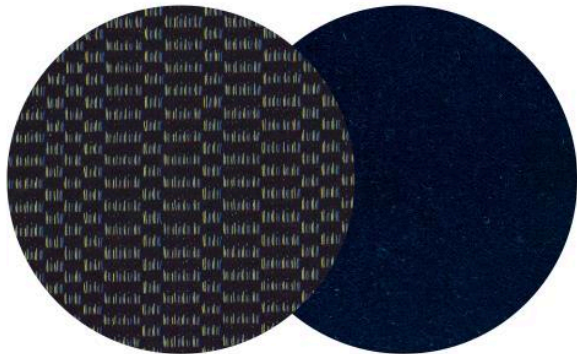

I.A.N.A. 2851800 Mohair 2971800

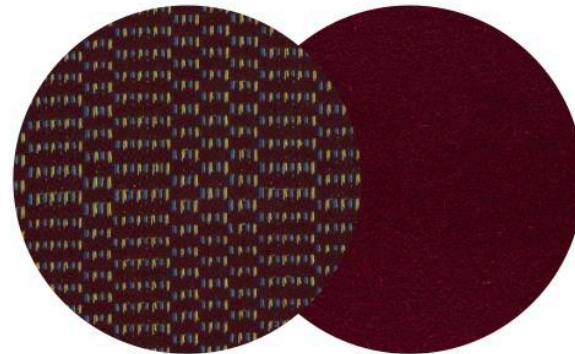

I.A.N.A. 2851750 Mohair 2971700

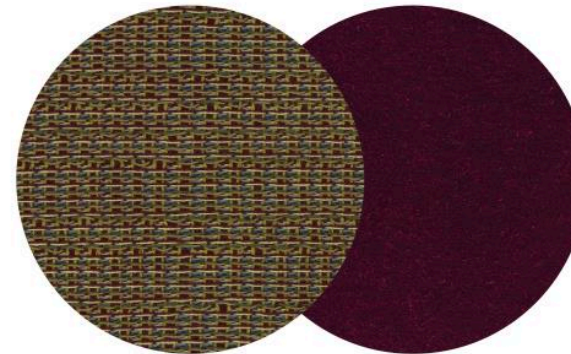

I.A.N.A. 2851450 Mohair 2971763

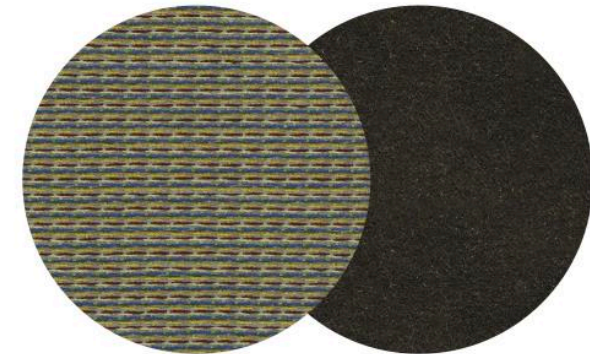

I.A.N.A. 2851900 Mohair 2971155

I.A.N.A. Composition 50% LAMBWOOL / 45% COTTON / 5% SILK - **MOHAIR** Composition 60% MOHAIR / 40% COTTON

Lilum

Seating system (range extension)

design Antonio Citterio

Technical details

NEW TERMINAL ELEMENT

LIL175TS_1

LIL175TD_1

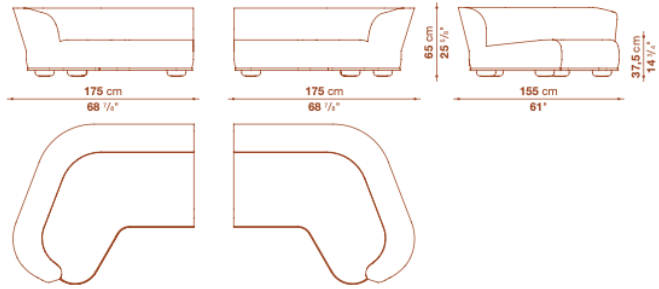

NEW CORNER ELEMENT

LIL165A

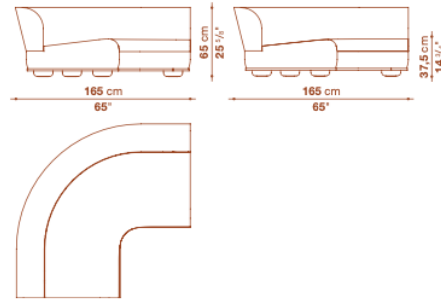

CORNER ELEMENT

LIL155AS

LIL155AD

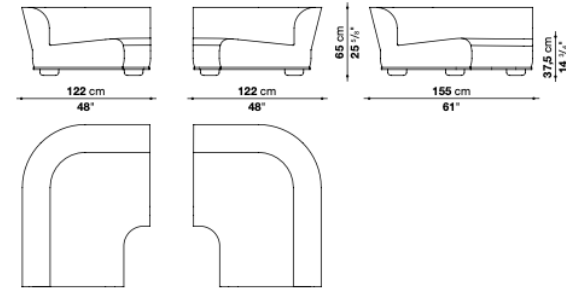

TERMINAL ELEMENT

LIL135TS

LIL135TD

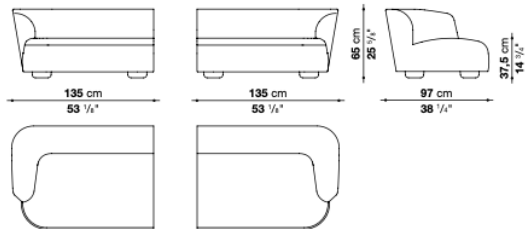

LIL175TS

LIL175TD

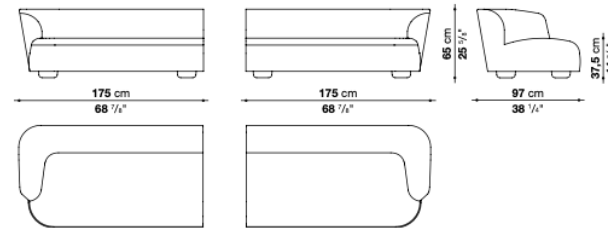

LIL240TS

LIL240TD

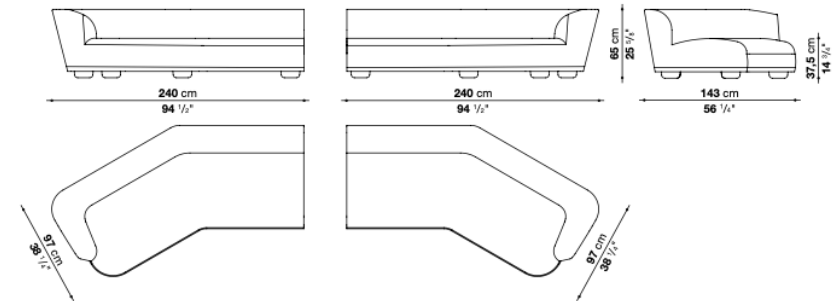

Arbiter

Seating system (range extension)

design Antonio Citterio

Technical details

NEW CENTRAL ELEMENT

AE158C

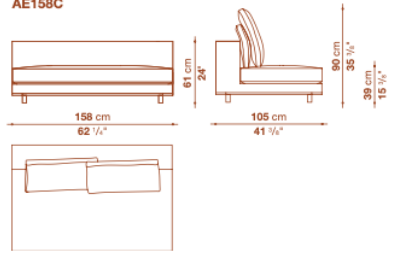

AE247C

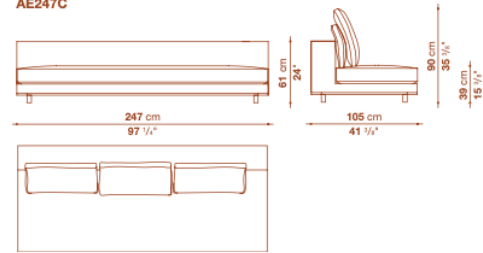

AE247C_1

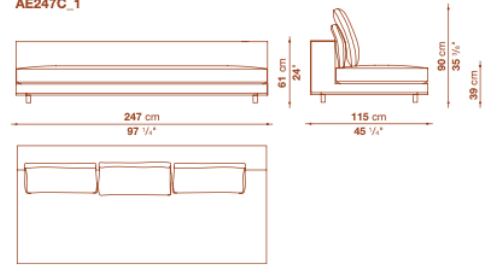

NEW TERMINAL ELEMENT

AE247S_1

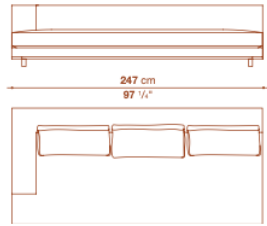

AE247D_1

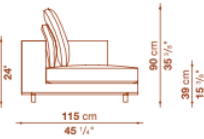
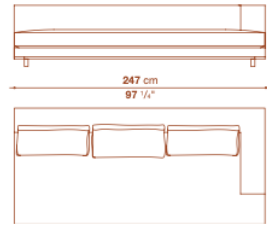

TERMINAL ELEMENT

AE158S

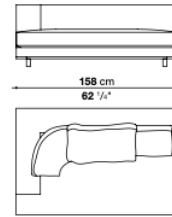

AE158D

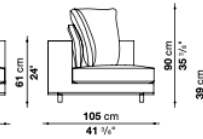
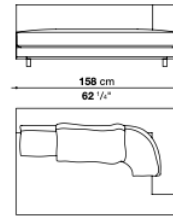

AE247S

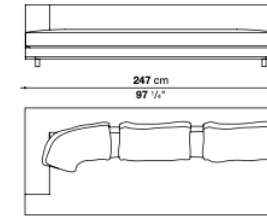

AE247D

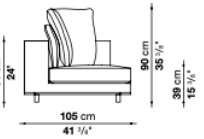
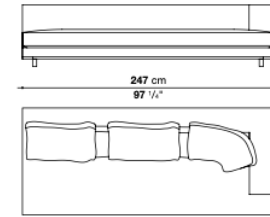

NEW CORNER ELEMENT

AE158AS

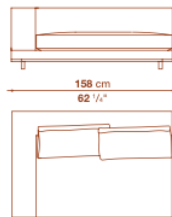

AE158AD

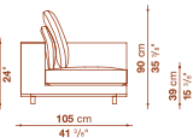
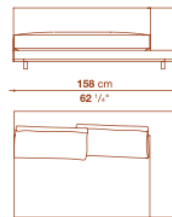

CORNER ELEMENT

AE270AS

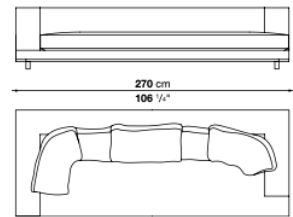

AE270AD

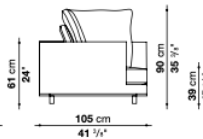
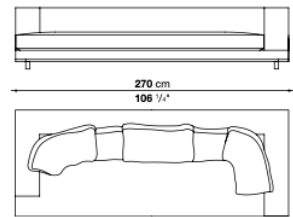

Lithos

Small table (range extension)

design Antonio Citterio



Technical details

NEW SMALL TABLE

TLT9

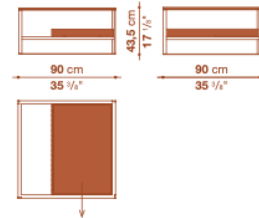

SMALL TABLES

TLT13

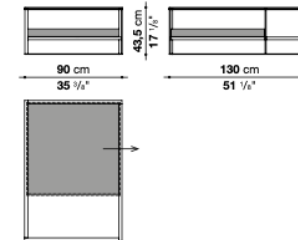

TLT18

