

Le Bambole

50th Anniversary

design Mario Bellini

Le Bambole 50th Anniversary - 40 / 89



**B&B Italia presents
Le Bambole [the dolls]
by Mario Bellini, in a
radically renewed version
perfectly aligned with
the most important and
contemporary trends of
colors and style.**

**Fifty years after their
initial creation, these
icons of Italian style
are evolving thanks
to new design choices
that make them even
more comfortable and
increasingly sustainable.**

**B&B
ITALIA**

1972

2022



“

I feel the pleasure of revisiting this family again, because it confirms to me that it is anything but aged; on the contrary, it is enjoying a thriving and promising second life, a rebirth done in a big way, done with enthusiasm, with breadth, with decorations and with the original flourishes. We have recovered its charm, its sumptuous floridity, its softness.

”

Mario Bellini

The collection



Bamb



ola



Ba



mbola

Bilbam



ibola

Granbambola



mboola

Granbambola

Le Bambole 50th Anniversary - 59 / 89



The new three-seater sofa with a deeper seat, that has earned it the name Granbambola and that aligns more with the new living needs.

Bai



mbooletto

Bamboletto

The back cushion can be placed in different positions and used as soft support. Thanks to a smart zip it could also be removed.

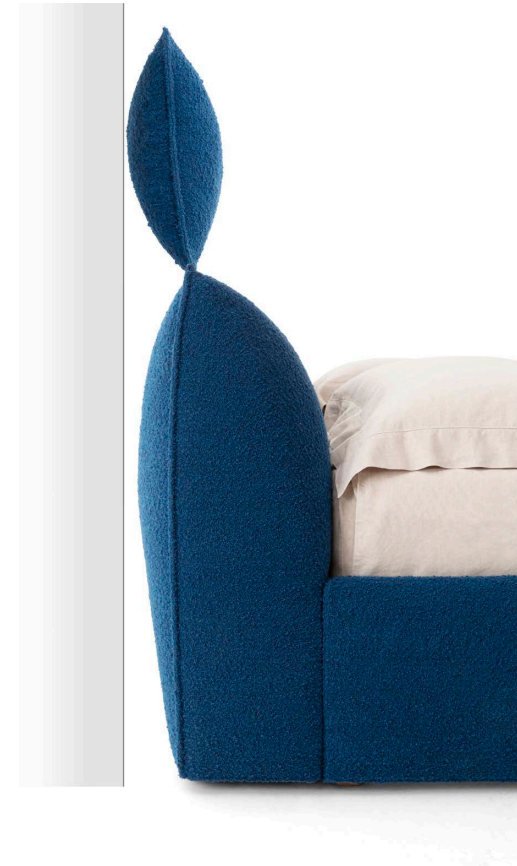

Comfort

Throughout their history, Le Bambole have seen slight adaptations in shape and construction techniques, proving that they are always able to keep up with the times.

Comfort is a key element of the design and it is guaranteed by a series of clever construction measures despite the fact that the amount of polyurethane used is considerably less.

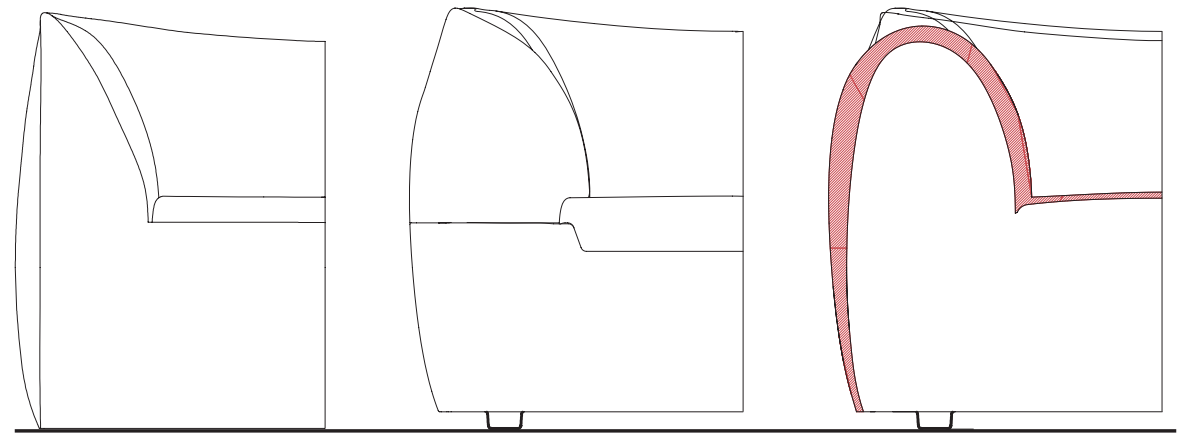

LE BAMBOLE '07

LE BAMBOLE 50TH ANNIVERSARY

COMPARISON IN SECTION

Sustainability

B&B Italia continues its commitment to developing always more sustainable products.

Today's challenge is to produce circular products, considering these as part of a cycle that include our lives and the environment around us.

Materials choices and construction details are confirming Le Bambole as an epitome of sustainability.



100%
disassemblability

c.a.
80%
circularity

B&B
ITALIA

Sustainability

Whereas in the original construction there was a metal frame drowned into polyurethane, this material is now reduced to a minimum to leave space for latest generations materials.

Recycled polyethylene is now used for the structure while polyurethane and thermoplastic elastomers define geometries and allow comfort and breathability.

A from 100% recycled polyethylene undercover wraps all these materials together.

>50%
input-output
recycling materials



Technical details

Bambola

LBA1

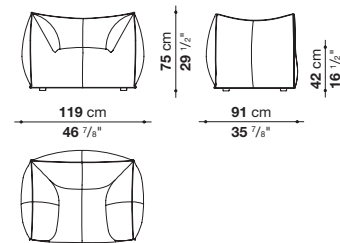

Bibambola

LBA2

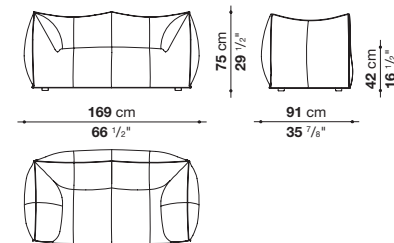

Granbambola

LBA3

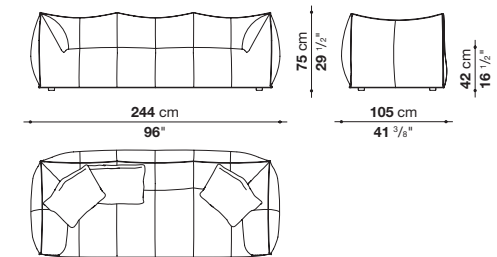

Bamboletto

LBL

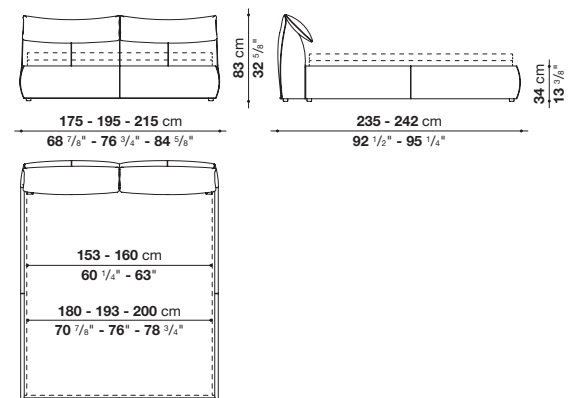

Technical details

Logo printed in silk-screen printing on jute placement under the product

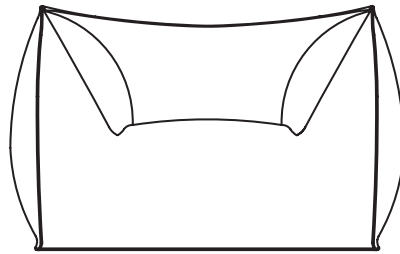

B&B | **Le Bambole** |
ITALIA | design Mario Bellini |
Made in Italy



Sila

Sila, is the new sablé fabric with a mixed fibers composition, available in eight colours chosen by Mario Bellini. Its pleasingly irregular, three-dimensional nature amplifies the effect of softness through a studied irregularity that seems reminiscent of natural, spontaneous surfaces. This sensation begins with sight and is completed by touch.



Sila

Composition
ACRYLIC 56%
POLYESTER 15%
VISCOSE 12%
COTTON 11%
LINEN 6%

Fabric flame resistance
BS 5852 - 0&1
TB 117 - 2013



SILA 100



SILA 280

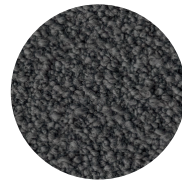

SILA 257

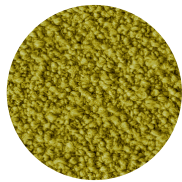

SILA 445

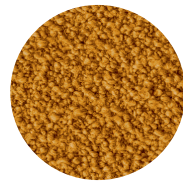

SILA 550

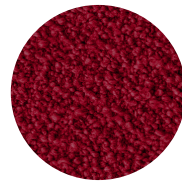

SILA 752

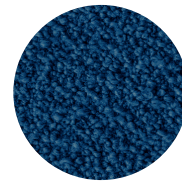

SILA 801

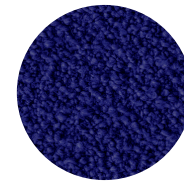

SILA 650



FABRIC SCALE AT 100%