

FÒGHER

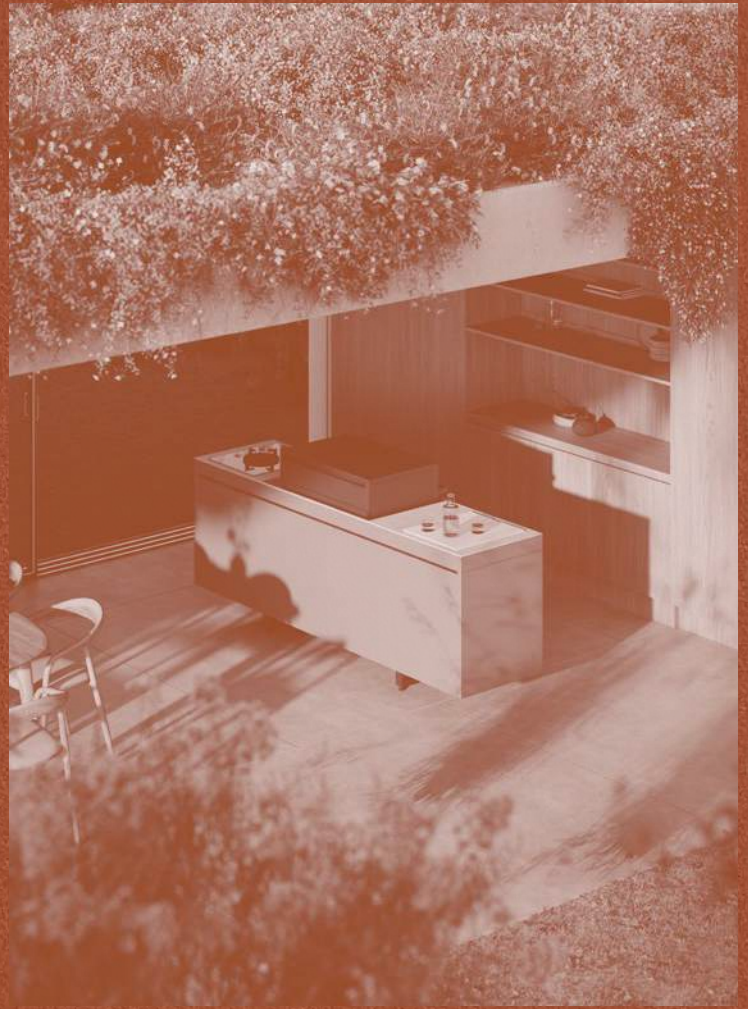

The outdoor kitchen Catalog

FÒGHER

The outdoor kitchen Catalog

Contenuti

Contents

Cucine da esterno	Outdoor kitchens	Nojara Agher Agher Premium Agher by Bastianich Lares	P.06 P.24 P.46 P.54 P.64
Sistemi di cottura	Cooking systems	Sistemi di cottura	P.88
Smoker	Smoker	Smoker	P.112
Caminetto	Fireplace	Caminetto	P.124
Informazioni tecniche	Technical information	Nojara Agher Lares Cooking systems	P.134 P.138 P.148 P.170
Contatti	Contacts		P.194

Nojara



Agher



Lares



Nojara

Spazio per cucinare, eleganza da condividere

La cucina Nojara è un sistema integrato che unisce area di cottura e tavolo conviviale in una composizione geometrica dal design equilibrato. Ogni elemento è progettato per dialogare con l'altro, creando uno spazio funzionale e armonioso, dove estetica, tecnologia e versatilità si incontrano per offrire un'esperienza outdoor completa ed elegante.

Nojara

Space to cook, elegance to share

The Nojara kitchen is an integrated system that combines cooking area and convivial table in a geometric composition with balanced design. The elements are designed to dialogue with each other to create a functional harmonious space where aesthetics, technology and versatility come together to deliver a complete elegant outdoor experience.



Nojara si articola in due strutture complementari: cucina e tavolo. La cucina a sbalzo, sorretta su un solo lato, conferisce leggerezza e sospensione, creando continuità visiva e armonia spaziale, trasformando l'outdoor in un ambiente funzionale e raffinato.

Nojara is divided into two complementary structures: kitchen and table. The cantilever kitchen, supported only one side, gives an idea of lightness and suspension, creating visual continuity and spatial harmony and turning any outdoor space into a functional refined place.

Le gambe strutturali di Nojara, dal design asimmetrico e realizzate con precisione ingegneristica, assicurano stabilità e leggerezza visiva. Questa configurazione ottimizza la distribuzione dei carichi, unendo performance tecnica e qualità estetica, esaltando l'eleganza e l'unicità del progetto contemporaneo.

The structural legs on Nojara, with their asymmetrical design and engineering precision, ensure stability and visual lightness. This configuration optimises load distribution, combining technical performance and aesthetic quality, enhancing the elegance and uniqueness of contemporary design.





Il design di Nojara pone chi cucina al centro della relazione con gli ospiti. La disposizione degli spazi favorisce interazioni continue, trasformando il gesto culinario in un elemento architettonico all'interno dello spazio outdoor, dove convivialità e funzionalità si sovrappongono in armonia.

Nojara is designed to allow the person cooking enjoy time with their guests. Arranged to favour continuous interaction, this kitchen transforms cooking into an architectural element within the outdoor space, a harmonious overlapping of conviviality and functionality.

Le composizioni Nojara integrano materiali pregiati e soluzioni tecnologiche certificate per esterno, come piani cottura a induzione o gas in vetroceramica. Il lavello YOZA e gli accessori dedicati completano un sistema pensato per l'architettura dello spazio, dove estetica e prestazioni dialogano senza compromessi.

Nojara compositions feature fine materials and technological solutions certified for outdoor use, such as glass-ceramic induction or gas hobs. The YOZA sink and dedicated accessories round out a system designed for the architecture of space, where aesthetics and performance dialogue without compromise.





The outdoor kitchen

Nojara unisce struttura bilanciata e soluzioni modulari per offrire stabilità e flessibilità senza pari. Dettagli progettuali accurati garantiscono integrazione discreta e continuità visiva, trasformando la complessità tecnica in un linguaggio di design contemporaneo e raffinato.

Nojara combines balanced structure and modular solutions to deliver unparalleled stability and flexibility. Carefully studied details ensure discreet integration and visual continuity, transforming technical complexity into a refined contemporary design language.

Le superfici di Nojara offrono ampie possibilità di personalizzazione, permettendo di adattare ogni elemento alle esigenze del progetto. Questa flessibilità valorizza l'armonia complessiva, trasformando cucina e tavolo in componenti unici, eleganti e coerenti con lo spazio outdoor.

The surfaces on Nojara are highly customisable, allowing each element to adapt to suit project requirements. This flexibility enhances its overall harmony, transforming the kitchen and table into unique, elegant components that fit beautifully into the outdoor space.





The outdoor kitchen

Ogni componente di Nojara, dalla struttura solida ai materiali di alta qualità, coniuga resistenza e raffinatezza estetica. Forma e funzione dialogano armoniosamente, dando vita a uno spazio outdoor unico, elegante e duraturo, dove ogni dettaglio valorizza il progetto architettonico.

From its solid structure to high quality materials, each of the components that make up Nojara combines resistance and refined aesthetics. Form and function dialogue harmoniously to create a unique, elegant, long-lasting outdoor space, where every detail enhances the architectural project.

Le proporzioni del tavolo Nojara favoriscono l'interazione tra commensali, mentre il piano a 91 cm garantisce ergonomia ottimale. Ogni gesto, sia in piedi sia da seduti, diventa fluido e naturale, trasformando lo spazio outdoor in un ambiente conviviale, elegante e funzionale.

The proportions of the Nojara table encourage interaction between diners, while the 91-cm top guarantees optimal ergonomics. Whether standing or sitting, every gesture is fluid and natural, transforming the outdoor space into a convivial elegant functional place.



Nojara

Plus della collezione



Blocchi indissolubili Two inseparable blocks

La struttura di Nojara si articola in due blocchi distinti: la zona conviviale con spessore di 10 cm e l'area cooking da 40 cm. Uniti in modo stabile e inscindibile, definiscono un sistema solido e coerente, in cui forma e funzione convivono in un equilibrio rigoroso e riconoscibile.

Nojara is divided into two distinct blocks: the 10-cm-thick convivial area and the 40-cm-thick cooking area. Joined as a stable inseparable whole, they form a solid consistent system in a meticulous recognisable balance of form and function.



Stabilità asimmetrica Asymmetrical stability

Le gambe strutturali di Nojara, caratterizzate da un disegno asimmetrico e da una struttura iniettata ad alta precisione, garantiscono un bilanciamento ottimale dell'intera composizione. La distribuzione dei carichi è studiata per coniugare solidità tecnica e valore estetico, rafforzando il carattere contemporaneo della cucina.

Nojara's structural legs, characterised by their asymmetrical design and high-precision injected structure, guarantee optimal equilibrium for the entire composition. The loads are distributed to combine technical solidity and aesthetic value, reinforcing the contemporary character of this kitchen.

Collection highlights



Piano da 12 mm 12 mm worktop

Il piano in ceramica super sinterizzata da 12 mm è concepito per garantire solidità, affidabilità e continuità estetica nel tempo. Il bordo a greca alleggerisce visivamente il volume, mentre il distacco dal perimetro della scocca crea un elegante effetto di sospensione. La combinazione tra spessore e densità del materiale assicura un'elevata resistenza a urti, graffi e stress termici, rendendolo ideale per l'ambiente outdoor.

The 12 mm ultra-sintered ceramic worktop is designed to ensure solidity, reliability and aesthetic continuity over time. The rooved edge adds visual lightness to the volume, while the detachment from the perimeter of the shell creates an elegantly suspended effect. The combination of the material's thickness and density makes it highly resistant to knocks, scratches and heat, making it ideal for outdoor use.



Vano tecnico integrato Built-in technical compartment

Una delle gambe di Nojara, volutamente disallineata per rafforzare l'equilibrio estetico dell'insieme, integra un vano tecnico funzionale. Questo elemento consente l'alloggiamento delle bombole e il passaggio nascosto delle tubazioni, mantenendo la struttura pulita e visivamente ordinata.

One of the legs on Nojara, deliberately misaligned to reinforce the aesthetic balance of the whole, houses a built-in functional technical compartment. This element hides the gas cylinders and pipes, ensuring the clean, visually sleek aesthetics of the structure.

Plus della collezione



Quadratura perfetta Perfect equilibrium

Le proporzioni del tavolo Nojara sono progettate per creare un equilibrio preciso tra volumi e relazioni. La distribuzione degli spazi favorisce l'interazione, mentre lo studio ergonomico assicura una fruizione confortevole, valorizzando la dimensione conviviale senza compromettere l'armonia formale.

The proportions of the Nojara table have been designed to create precisely balanced volumes and relationships. The spaces are distributed to encourage interaction, the ergonomics studied to ensure comfortable use, enhancing the convivial dimension without compromising formal harmony.



Altezza ergonomica Ergonomic height

Il piano di lavoro è posizionato a 91 cm da terra, un'altezza studiata per garantire un'ergonomia naturale e bilanciata. Questa misura favorisce un utilizzo fluido e confortevole, migliorando la relazione tra gesto, postura e spazio durante ogni fase di utilizzo.

The worktop is 91 cm off the ground, a height designed to ensure natural balanced ergonomics. This height aids fluid comfortable use, improving the relationship between gesture, posture and space at each phase of preparation.

Collection highlights



Configurazioni cromatiche Color configurations

Nojara offre un elevato livello di personalizzazione grazie alla possibilità di combinare fino a 12 configurazioni differenti tra superfici in gres e colori della struttura. Questa libertà progettuale consente di adattare la cucina a contesti architettonici e stilistici diversi, mantenendo coerenza estetica e identità formale. Un sistema pensato per interpretare lo spazio outdoor attraverso scelte materiche precise e distintive.

Nojara is highly customisable thanks to a possible choice of 12 different combinations chosen from stoneware surfaces and structure colours. This design freedom allows for adaptation of the kitchen to different architectural and stylistic contexts, while maintaining aesthetic coherence and formal identity. A system designed to interpret any outdoor space with precise distinctive choices of material.



Area cooking su misura Tailor-made cooking area

L'area cooking di Nojara si sviluppa attorno a una postazione centrale, configurabile con barbecue FGB 750 o sistema lavello YOZA 950 ST. Nella composizione a L, le proporzioni e la modularità permettono l'integrazione armonica di piani a gas, induzione ed elementi dedicati, definendo una cucina flessibile e coerente dal punto di vista progettuale.

The cooking areas on Nojara develops around a central station, which can be configured with a FGB 750 barbecue or a YOZA 950 ST sink system. The proportions and modularity of the L composition allow for harmonious integration of gas and induction hobs and dedicated elements, creating a flexible kitchen that is coherent in design terms.

Agher

Armonia ed equilibrio in un unico volume

La cucina Agher è un monoblocco compatto e performante, dove ogni elemento è studiato per offrire massima efficienza e solidità. La struttura compatta, realizzata con materiali selezionati, unisce resistenza e funzionalità in un design essenziale, capace di trasformare lo spazio outdoor in un ambiente elegante e completo.

Agher

Harmony and balance in a single volume

The Agher kitchen is a compact high-performance monobloc, each element designed to deliver maximum efficiency and sturdiness. Made with selected materials, its compact structure combines resistance and functionality in an essential design that transforms any outdoor space into an elegant rounded environment.



Ispirata all'acero delle Dolomiti, la cucina Agher interpreta la forza della natura in una forma compatta e funzionale, capace di esprimere solidità, equilibrio formale, una presenza elegante e riconoscibile. Un progetto outdoor che trasforma lo spazio esterno in un ambiente dedicato alla convivialità, dove design e funzionalità convivono in modo armonioso.

Inspired by maple wood from the Dolomites, the Agher kitchen interprets the power of nature in a compact functional form, expressing sturdiness and balanced form in an elegant recognisable presence. A project that transforms any outdoor space into a harmonious mix of form and function, the perfect setting for socialising.

Agher è una cucina outdoor progettata per favorire l'interazione. La configurazione monoblocco garantisce ordine ed efficienza, offrendo una superficie di lavoro pratica e ben organizzata, pensata per accompagnare ogni momento di condivisione.

Agher is an outdoor kitchen designed to encourage sharing. Its monobloc configuration guarantees order and efficiency, offering a practical well-organised work surface designed to bring people together.





The outdoor kitchen

P.30

Le dimensioni contenute di 2400x600 mm racchiudono tutta la praticità di una cucina completa, progettata per offrire prestazioni elevate senza rinunciare all'equilibrio delle proporzioni. Agher trasferisce all'esterno le logiche funzionali dell'ambiente indoor, adattandole a un utilizzo all'aperto intuitivo, fluido e versatile.

In just 240x60 cm, it encapsulates all the practicality of a complete kitchen, designed to offer high performance without compromising on the balance of proportions. Agher takes all the functional logics of an indoor kitchen outside, adapting them for intuitive, seamless, versatile outdoor use.

Superfici, altezze e distanze sono studiate per garantire comfort ed efficienza operativa. L'ergonomia del progetto assicura una fruizione semplice e ordinata, adatta a ogni fase della preparazione.

Surfaces, heights and distances have been studied to ensure ease of use and efficiency. This project's ergonomics make for simple uncluttered cooking from start to finish.



P.31

Agher



The outdoor kitchen

P.32

Agher

P.33

Il progetto Agher è definito da una composizione rigorosa di volumi e superfici, dove pieni e vuoti costruiscono una geometria chiara e riconoscibile. La cucina si configura come un elemento architettonico autonomo, capace di ordinare lo spazio outdoor e di inserirsi nel contesto con equilibrio e continuità formale.

The Agher project features a meticulous composition of volumes and surfaces, where open and closed spaces create clear recognisable geometrics. This kitchen is configured as an independent architectural element that organises any outdoor space, fitting into any setting with balance and continuity of form.

La configurazione compatta consente una gestione ordinata delle funzioni, ottimizzando lo spazio disponibile senza rinunciare alla praticità. Ogni elemento è posizionato per garantire fluidità operativa e una fruizione efficiente nell'uso quotidiano.

Its compact configuration allows for streamlined cooking, optimising available space without compromising on practicality. Each element is positioned to ensure flow and efficient daily use.





The outdoor kitchen

P.36

Il colore è parte integrante del progetto Agher e contribuisce in modo determinante alla percezione dello spazio. Le finiture sono studiate per valorizzare materiali e superfici, definendo l'identità della cucina e rafforzando il dialogo con l'architettura e l'ambiente circostante.

Colour is an integral part of the Agher project and contributes significantly to the perception of space. The finishes have been studied to enhance materials and surfaces, defining the identity of the kitchen and reinforcing its dialogue with the surrounding environment and architecture.

Le palette cromatiche spaziano dalla profondità del nero e dell'ossidiana, alla calda intensità di Terra di Siena, fino alla delicatezza di Salvia Antica e alla luminosità di Seta Materica. Ogni colore dialoga con l'architettura outdoor valorizzandone l'equilibrio estetico.

The colour palettes range from the depth of black and Obsidian and the warm intensity of Sienna, through to the delicacy of Ancient Sage and the sheen of Material Silk. Each colour dialogues with the outdoor architecture enhancing its aesthetic balance.



P.37

Agher

Plus della collezione



Capacità torsionale Phobos® Phobos® torsional capacity

Il sistema brevettato Phobos® garantisce un'elevata rigidità torsionale e un efficace isolamento termico. La longevità della cucina è assicurata dalla riduzione delle dilatazioni dei materiali e dall'unione coesa e leggera del piano in MDI alla struttura sottostante. La struttura iniettata Agher offre una sensazione solida e compatta al tatto, eliminando la risonanza tipica della lamiera tradizionale.

The patented Phobos® system guarantees high torsional rigidity and effective thermal insulation. This ensures a long life for the kitchen thanks to reduced material dilation and the cohesive lightweight combination of the MDI worktop with the structure below. The injected structure of Agher is solid and compact to the touch, the typical resonance of traditional sheet metal totally eliminated.

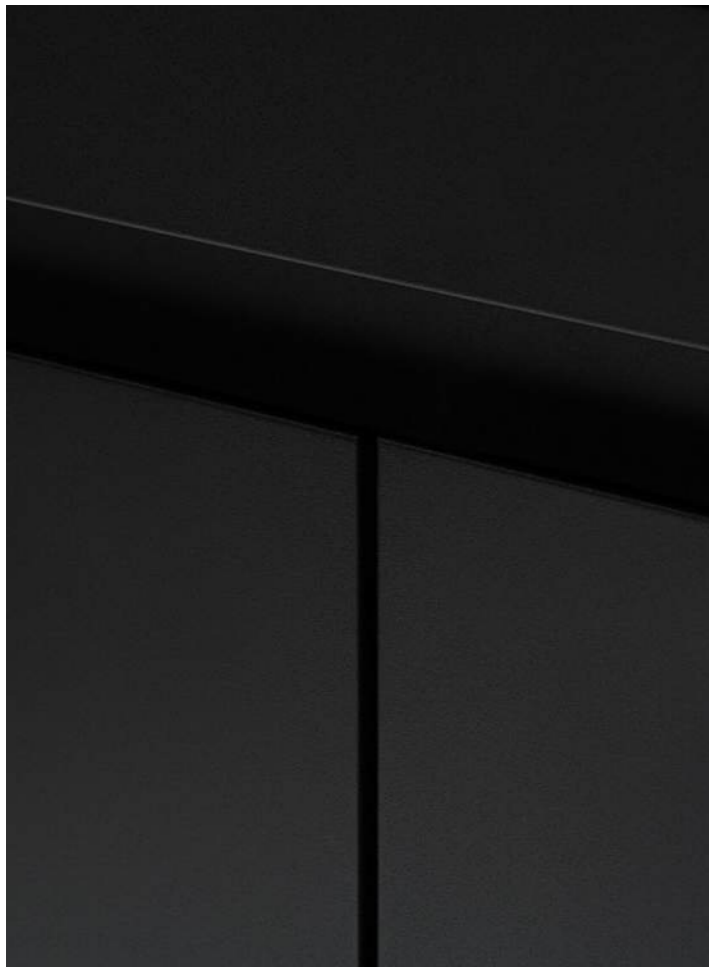

Struttura avanzata grazie allo studio dei materiali Advanced structure thanks to carefully studied materials

La struttura avanzata è realizzata attraverso una combinazione calibrata di acciaio inox, zinco-magnesio e alluminio. Questa sinergia di materiali consente di ottenere un'elevata rigidità strutturale mantenendo al tempo stesso un profilo leggero, contribuendo a stabilità, precisione costruttiva e durata nel tempo.

The advanced structure is the result of a calibrated combination of stainless steel, zinc-magnesium and aluminium. This synergy of materials makes it possible to achieve high structural rigidity while maintaining a light profile, contributing to stability, construction precision and durability.

Collection highlights

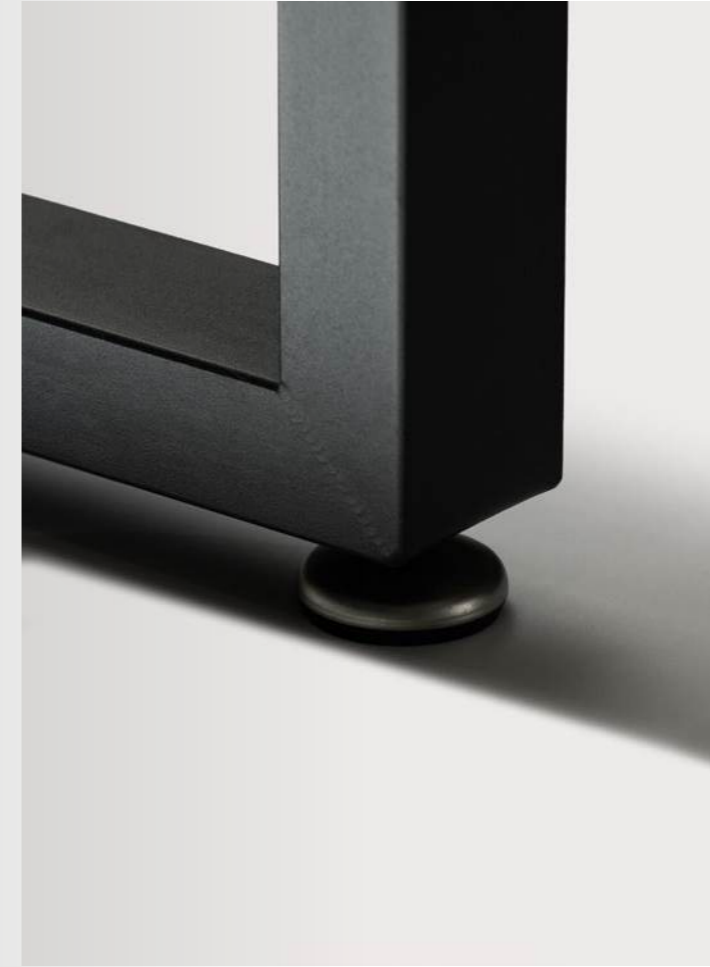

Piedini in acciaio inox ad alta regolazione Highly adjustable stainless steel feet

I piedini regolabili in acciaio inox con appoggio in gomma sono progettati per garantire massima stabilità e sicurezza. L'elevata capacità di regolazione consente un livellamento preciso, assicurando un perfetto adattamento della cucina e una stabilità ottimale su qualsiasi superficie esterna.

The adjustable stainless steel feet with rubber tips are designed to ensure maximum stability and safety. Highly adjustable, they ensure precise levelling, for optimum stability and to ensure the kitchen sits perfectly on any outdoor surface.

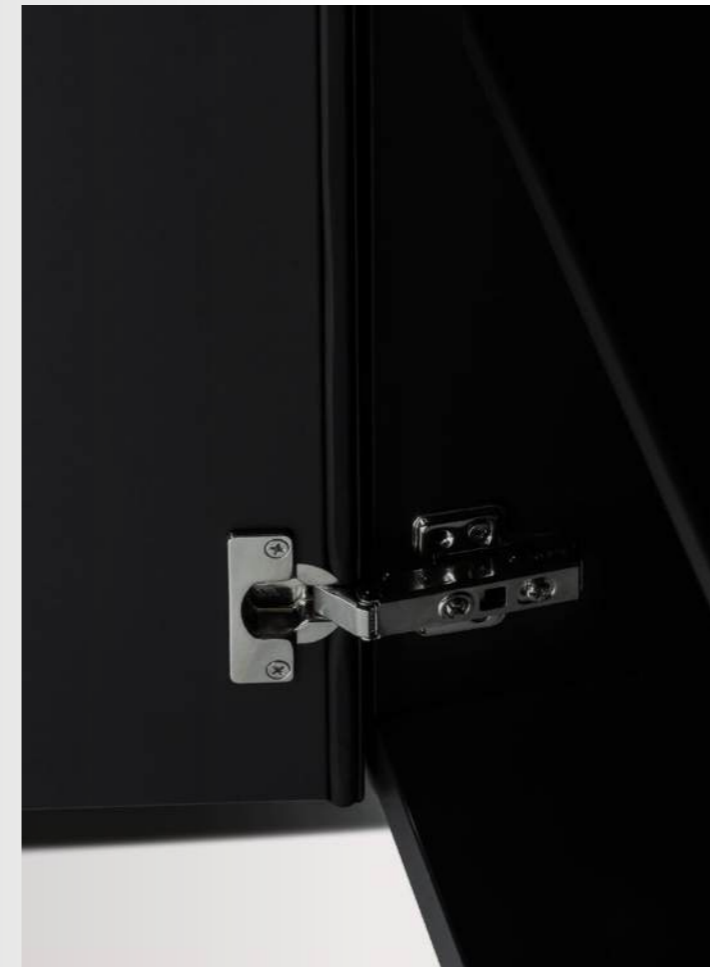

Cerniere outdoor in acciaio inox Outdoor stainless steel hinges

Le cerniere in acciaio inox sono progettate per resistere a corrosione, umidità e sbalzi termici, anche in condizioni climatiche estreme. Dotate di ammortizzatore integrato, garantiscono una chiusura fluida e controllata delle ante, migliorando comfort d'uso e durata del sistema.

The stainless steel hinges are designed to resist corrosion, moisture and temperature changes, even in extreme weather conditions. Fitted with an integrated damper, they guarantee smooth controlled closing of the doors, improving ease of use and durability of the system.

Plus della collezione



Ventilazione nascosta e design funzionale Hidden ventilation and functional design

Le cucine Agher integrano prese d'aria sapientemente nascoste, progettate per garantire una corretta ventilazione del vano bombola e il funzionamento ottimale del barbecue. Questa soluzione tecnica preserva un'estetica pulita e minimale, assicurando al contempo sicurezza, efficienza e affidabilità nel tempo.

Agher kitchens feature cleverly hidden air vents, designed to ensure proper ventilation of the gas cylinder compartment and optimal barbecue performance. This solution maintains the sleek minimal aesthetics of the kitchen without compromising on long-term safety and efficiency.



Snackbar Snackbar

La snack bar Agher è progettata per aumentare la profondità operativa della cucina e consentire l'installazione a ridosso della parete. La versione con profondità di 250 mm, integra una superficie aggiuntiva che, abbinata agli sgabelli, si trasforma in una pratica zona conviviale, mantenendo continuità estetica e funzionale con l'intera composizione.

The Agher snack bar is designed to increase the kitchen's worktop depth and allow for installation against a wall. The 25-cm-deep version adds an extra surface that, with the addition of stools, can be used as a practical convivial area, maintaining aesthetic and functional continuity with the entire composition.

Collection highlights



Sgabelli Agher Agher stools

Gli sgabelli sono disponibili nelle sei colorazioni Agher, per garantire coerenza estetica con la cucina e il tavolo. Questa versatilità cromatica permette di creare una zona conviviale armoniosa, mantenendo continuità visiva e un elevato livello di comfort nell'utilizzo quotidiano.

Stools are available in the six Agher colourways to match the kitchen and table. This choice helps to create a harmonious convivial space, maintaining visual continuity and a high level of comfort for everyday use.



Tavolo Agher Agher table

Il tavolo Agher è progettato per integrarsi con la cucina e creare una zona dedicata alla convivialità. Può essere configurato come prolunga lineare o disposto a L, adattandosi alle diverse esigenze di spazio e favorendo un utilizzo fluido e funzionale dell'ambiente outdoor.

The Agher table is designed to match the kitchen and create an area dedicated to conviviality. It can be added as a linear or L-shape extension depending on available space and requirements, promoting fluid functional use of the outdoor setting.

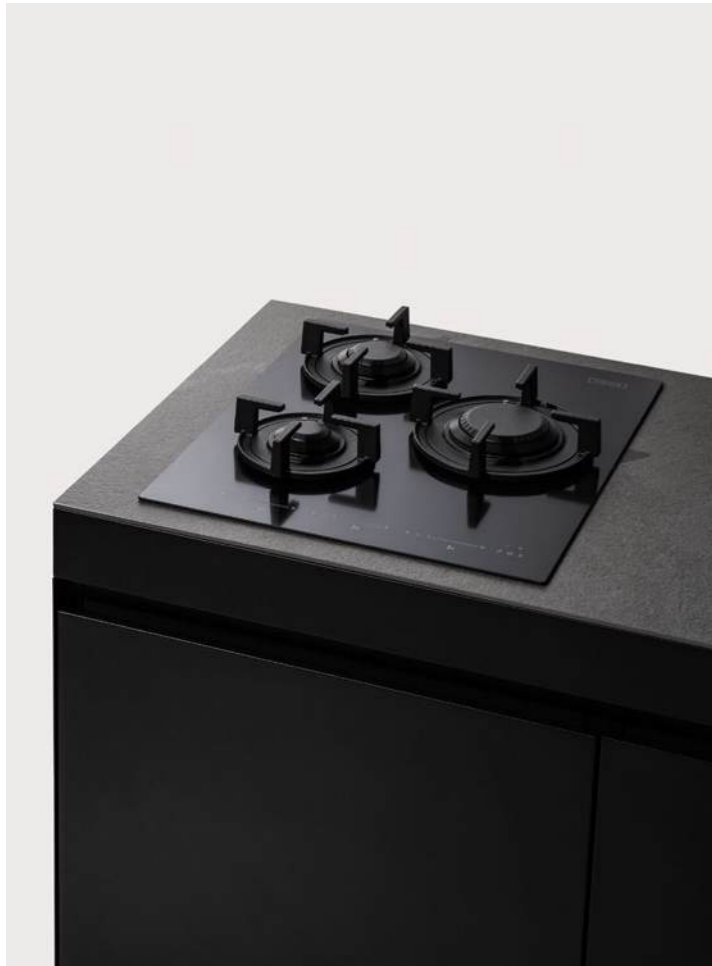

Piano cottura a gas 3 fuochi 3-burner gas cooktop

Il piano cottura a gas Fiuma a tre fuochi (FEF 4532 SE) è progettato per offrire potenza, precisione e affidabilità in ambito outdoor. La gestione elettronica touch sostituisce le tradizionali manopole, migliorando l'ergonomia e riducendo il rischio di infiltrazioni d'acqua, per prestazioni costanti nel tempo.

The Fiuma three-burner gas cooktop (FEF 4532 SE) is designed to offer power, precision and reliability for outdoor cooking. The electronic touch-control system replaces traditional knobs, improving ergonomics and reducing the risk of water infiltration, for constant performance over time.



Piano cottura a gas 1 fuoco 1-burner gas cooktop

Il piano cottura Fiuma a un fuoco dual (FEF 4514 SE) con accessorio wok combina la potenza del gas con un controllo elettronico avanzato. Il sistema intelligente monitora costantemente la fiamma e ne garantisce la riaccensione automatica in caso di spegnimento accidentale, assicurando continuità di utilizzo, sicurezza e massima precisione durante la cottura.

The Fiuma dual-burner hob cooktop (FEF 451 ST) with wok support combines the power of gas with advanced electronic control. The intelligent system constantly monitors the flame and guarantees automatic reignition if it is accidentally extinguished, ensuring continuity of use, safety and maximum precision during cooking.



Piano cottura a induzione Induction cooktop

Il piano cottura a induzione Lùxar di Fògher interpreta la cucina outdoor attraverso un linguaggio essenziale e contemporaneo. La superficie in vetroceramica satinata integra tre zone di cottura in un unico piano continuo, dove la grafica discreta accompagna un'interazione intuitiva. Tecnologia e design si incontrano per offrire precisione, controllo e un'esperienza di cottura pulita e funzionale.

The Lùxar induction cooktop by Fògher is an essential contemporary feature of the outdoor kitchen. A satin-finish glass-ceramic surface integrates three cooking zones in a single continuous cooktop, its discreet graphics teamed with intuitive interaction. Technology and design come together to deliver precision, control and a sleek functional cooking experience.



Copertura Piano Cooktop lid

La copertura per piano cottura è studiata per proteggere la superficie in vetroceramica in ambiente outdoor. Fornita in dotazione, contribuisce a schermare il piano da agenti atmosferici, polvere e urti accidentali, preservandone nel tempo funzionalità ed equilibrio estetico.

The cooktop comes with a lid designed to offer outdoor protection for the glass-ceramic surface. It acts as a shield against the elements, dust and accidental knocks for long-term protection of the cooktop's form and function.



Lavello in acciaio inox Stainless steel sink

Il lavello YÒZA 450 ST, installato sopra il top, è dotato di vasca abbattibile, combinando funzionalità e flessibilità. Questa soluzione consente di ottimizzare lo spazio di lavoro quando il lavello non è in uso, garantendo continuità estetica e praticità operativa in ambiente outdoor. Materiali resistenti e finiture curate assicurano durata, facilità di manutenzione e prestazioni costanti nel tempo.

The over-mounted YÒZA 450 ST sink is fitted with a foldable bowl, combining functionality and flexibility. This solution allows you to optimise the workspace when the sink is not in use, ensuring aesthetic continuity and operational practicality in an outdoor environment. Resistant materials and careful finishes ensure durability, ease of maintenance and constant performance over time.



Lavello in acciaio grande Large stainless steel sink

Il lavello YÒZA 950 rappresenta una soluzione completa per chi ricerca massima funzionalità. Realizzato interamente in acciaio inox 316 con finitura Reditage, assicura elevata resistenza e una resa estetica costante nel tempo. La vasca di grandi dimensioni, abbinata al miscelatore in acciaio inox con doccino estraibile e agli accessori dedicati, semplifica le attività di preparazione e lavaggio in ambiente outdoor.

The YÒZA 950 sink is a complete solution for those wanting maximum functionality. Made entirely of 316 stainless steel with Reditage finish, it ensures high resistance and a constant aesthetic performance over time. The large bowl teamed with a stainless steel mixer with pull-out spray and dedicated accessories, simplifies food preparation and washing when cooking outdoors.



Frigo-freezer outdoor Outdoor fridge-freezer

Il frigorifero ad incasso è progettato per integrarsi con discrezione nelle cucine outdoor Agher. Installato a scomparsa dietro le ante, unisce funzionalità e pulizia formale, offrendo uno spazio refrigerato adatto alla conservazione di alimenti e bevande. La presenza del mini congelatore amplia la versatilità d'uso, garantendo prestazioni affidabili in ogni stagione.

The built-in fridge is designed to fit discreetly into Agher outdoor kitchens. Hidden behind the doors, it combines no-frills form and function, providing a refrigerated space for storing food and drinks. The mini freezer extends its usefulness, ensuring reliable performance whatever the season.



Cantina vini outdoor Outdoor wine cellar

La cantinetta vino outdoor completa l'esperienza Fògher dedicata alla convivialità all'aperto. Progettata per mantenere le bottiglie alla temperatura ideale, offre una soluzione raffinata e funzionale per la conservazione del vino. Un elemento che arricchisce la cucina outdoor, aggiungendo valore e attenzione al dettaglio in ogni momento di condivisione.

The outdoor wine cellar elevates the Fògher outdoor living experience. Designed to keep bottles at the ideal temperature, it is a refined functional wine storage solution. An element that adds even more value to the outdoor kitchen with attention to detail for every moment of sharing.

Agher Premium

Agher Premium rappresenta l'evoluzione del sistema Agher, portando l'outdoor a un livello superiore di equilibrio e raffinatezza. Il piano unico attraversa la composizione, creando continuità visiva e armonia nello spazio. Linee pulite e proporzioni armoniche definiscono un ambiente ordinato, trasformando la cucina in un contesto elegante, funzionale e integrato con l'esterno.

Agher Premium

Agher Premium represents the evolution of the Agher system, taking the outdoor to a higher level of balance and sophistication. The unique top runs through the composition, creating visual continuity and harmony in the space. Clean lines and harmonious proportions define an orderly environment, transforming the kitchen into an elegant, functional context integrated with the outside.



Agher Premium evolve il sistema Agher introducendo una nuova interpretazione materica del piano di lavoro. Il gres opaco da 12 mm diventa elemento distintivo del progetto, definendo una superficie continua, essenziale e visivamente rigorosa, capace di rafforzare il carattere architettonico della cucina outdoor e di trasmettere una sensazione di solidità e armonia estetica all'intero ambiente.

Agher Premium evolves the Agher system by introducing a new material interpretation of the work top. The 12 mm matte stoneware (½ in) becomes a distinctive element of the project, defining a continuous, essential and visually rigorous surface, capable of strengthening the architectural character of the outdoor kitchen and transmitting a feeling of solidity and aesthetic harmony to the entire environment.

Le configurazioni disponibili offrono la possibilità di posizionare i sistemi di cottura e gli elettrodomestici all'interno del top della cucina in modo chiaro e armonioso. Il piano unico collega visivamente tutti gli elementi, semplificando l'uso quotidiano e conferendo alla composizione un senso di linearità e raffinatezza, esaltando l'eleganza complessiva della cucina.

The available configurations offer the possibility of positioning the cooking systems and appliances inside the kitchen top in a clear and harmonious way. The single top visually connects all the elements, simplifying the everyday use and giving the composition a sense of linearity and refinement, enhancing the overall elegance of the kitchen.





Agher Premium introduce due nuovi colori per la struttura: Soffio di Baia, un azzurro acqua luminoso, e Bronzo Vivo, una tonalità scura e calda con riflesso leggermente metallizzato, che conferisce profondità e carattere. L'assenza di combinazioni predefinite tra struttura e piano consente libertà di scelta entro le opzioni disponibili, valorizzando l'estetica complessiva e creando armonia con gli altri elementi della cucina.

Agher Premium introduces two new colors for the structure: Bay Breeze, a luminous aqua blue, and Live Bronze, a dark, warm shade with a slightly metallic reflection, which gives depth and character. The absence of predefined combinations between structure and floor allows freedom of choice within the available options, enhancing the overall aesthetic and creating harmony with the other elements of the kitchen

Le nuove finiture Duna chiara, dalla tonalità delicata, e Roccia bruna, più scura e profonda, ampliano ulteriormente le possibilità espressive del gres, valorizzandone texture, matericità e profondità. Il piano continuo che attraversa l'intera composizione rafforza la percezione di ordine e armonia dello spazio cucina, conferendo eleganza e coerenza visiva anche nelle configurazioni più articolate.

The new finishes Light dune, with its delicate hue, and Dark rock, darker and deeper, further expand the expressive possibilities of stoneware, enhancing its texture, materiality and depth. The continuous worktop that runs through the entire composition reinforces the perception of order and harmony of the kitchen space, providing elegance and visual coherence even in the most articulated configurations.



Agher by Bastianich

La cucina Agher Bastianich è un monoblocco compatto e deciso, espressione di una visione autentica della cucina outdoor. Interamente realizzata in acciaio inox Reditage, combina solidità materica e precisione costruttiva in un design essenziale e riconoscibile. La struttura monolitica valorizza il metallo come elemento centrale, dando vita a una cucina che interpreta lo spazio esterno con carattere ed equilibrio.

Agher by Bastianich

The Agher Bastianich model is a compact assertive monobloc that expresses an authentic vision of the outdoor kitchen. Entirely made of Reditage stainless steel, it combines material solidity and construction precision in essential recognisable design. Its monolithic structure emphasises the metal as a central element, creating a kitchen that interprets outdoor space with character and balance.



Agher per Joe Bastianich interpreta l'outdoor come un sistema integrato tra cucina e convivialità. Volumi, proporzioni e flussi sono studiati per valorizzare lo spazio, trasformando la preparazione dei pasti in un'esperienza architettonica coerente, raffinata e funzionale.

Agher by Joe Bastianich interprets the outdoors in a system that integrates cooking and conviviality. Volumes, proportions and flows have been designed to enhance a space in which meal preparation becomes a coherent, sophisticated, functional architectural experience.

L'interno in raffinato color ossidiana contrasta con l'acciaio esterno, sottolineando dettagli sofisticati. Ogni elemento della cucina Agher per Joe Bastianich integra modularità e precisione tecnica, creando un ambiente outdoor esclusivo.

In a refined obsidian colour, the interiors contrast with the steel exterior, emphasising elegant details. Each element of the Agher by Joe Bastianich kitchen integrates modularity and technical precision, creating an exclusive outdoor environment.



The outdoor kitchen

P.58



Agher by Bastianich

P.59



Ogni cucina è unica e numerata, frutto di cura artigianale e attenzione ai dettagli. L'interno in raffinato color ossidiana aggiunge eleganza discreta, mentre materiali esclusivi e finiture di pregio trasformano la cucina outdoor in un'esperienza sensoriale e scenografica.

Each kitchen is unique and numbered, the result of craftsmanship and attention to detail. In a refined obsidian colour, the interiors add discreet elegance, while exclusive materials and fine finishes transform the outdoor kitchen into a sensory scenic experience.

Il rivestimento in acciaio inox 316 Reditage, abbinato al piano MDi Pacific Gris, garantisce durabilità e resistenza. Ogni dettaglio della cucina di Joe Bastianich valorizza le superfici e crea continuità visiva, esaltando eleganza e rigore progettuale.

A 316 Reditage stainless steel finish combines with the MDi Pacific Gris worktop to guarantee durability and resistance. Every detail of this kitchen by Joe Bastianich enhances the surfaces and creates visual continuity, adding elegance and design precision.





Lares

La cucina modulare che disegna il tuo spazio

La cucina Lares coniuga modularità e versatilità, offrendo soluzioni personalizzabili per ogni esigenza outdoor. I materiali di alta qualità, uniti a componenti studiati per prestazioni elevate, garantiscono durabilità, facilità d'uso e un'esperienza di cottura fluida e professionale. Lares interpreta l'outdoor con equilibrio tra estetica e funzionalità, rendendo ogni spazio unico e armonioso.

Lares

The modular kitchen that shapes your space

The Lares kitchen combines modularity and versatility, delivering customisable solutions for every outdoor need. Used together with components designed for high performance, high-quality materials guarantee durability, ease of use and a smooth professional cooking experience. Lares embodies outdoor living in a balance of form and function that makes every space unique and harmonious.



The outdoor kitchen

P.66

Lares

P.67

Lares è un sistema cucina concepito come elemento architettonico per l'outdoor contemporaneo. La modularità diventa strumento di progetto, capace di definire composizioni precise, funzionali e coerenti con lo spazio. Ogni configurazione valorizza proporzioni, allineamenti e continuità formale, offrendo soluzioni affidabili e altamente performanti.

Lares is a kitchen system conceived as an architectural element for contemporary outdoor cooking. Its modularity becomes a tool for designing precise, functional compositions that fit beautifully into their setting. Each configuration enhances proportions, alignments and continuity of form, ensuring reliable, high-performance solutions.

La progettazione di Lares ruota attorno alla libertà compositiva. Un'ampia gamma di moduli e sistemi di cottura Fògher consente di sviluppare configurazioni personalizzate, adatte a contesti residenziali e contract. Il sistema garantisce ordine progettuale, chiarezza funzionale e un linguaggio formale rigoroso.

Lares offers complete design freedom in terms of composition. A wide range of Fògher modules and cooking systems allows for the development of customised configurations that meet either residential or contract requirements. The system guarantees project planning, functional clarity and a meticulous design language.





The outdoor kitchen

P.70

Il piano iniettato con il top in MDI nasce da un processo produttivo brevettato che integra una lastra compatta con un'anima interna alleggerita. Questa struttura incrementa stabilità, robustezza e durata nel tempo, assicurando prestazioni costanti a contatto con calore, acqua e agenti esterni, mantenendo inalterate qualità materiche e cromatiche.

Injected countertop with MDI top is the result of a patented production process that sees a compact shell filled with a lighter inner core. This structure increases stability, robustness and durability, ensuring constant performance in contact with heat, water and external agents, while maintaining material and chromatic qualities.

Il piano di lavoro MDI rappresenta una sintesi avanzata tra ricerca sui materiali e progettazione funzionale. Realizzato con materie naturali pressate e cotte a oltre 1100°C, offre una superficie monolitica ad alte prestazioni, capace di garantire resistenza, igiene e continuità estetica anche in ambienti outdoor complessi.

MDI worktops are the advanced synthesis of research into materials and functional design. Made with natural materials, compacted and fired at over 1100°C, they offer a high-performance monolithic surface that guarantees resistance, hygiene and aesthetic continuity even in complex outdoor environments.



P.71

Lares



Lares si completa attraverso una gamma di accessori progettati per integrarsi in modo organico nel sistema cucina. Elementi funzionali e discreti ampliano le possibilità operative, mantenendo continuità formale e coerenza progettuale. Ogni accessorio contribuisce a definire uno spazio di lavoro ordinato, efficiente e misurato.

Completing Lares is a range of accessories designed to integrate naturally into the kitchen system. Discreet and functional, these elements increase cooking options while preserving continuity of form and design coherence. Each accessory helps create an uncluttered, efficient, proportioned workspace.

Le finiture Ossidiana e Seta Materica offrono interpretazioni materiche e sofisticate delle superfici. Ossidiana si distingue per il suo nero intenso e profondo, mentre Seta Materica si presenta come un colore chiaro, elegante e delicato. Entrambe le varianti valorizzano volumi, linee e texture, creando armonia e continuità visiva nel progetto.

The Obsidian and Material Silk finishes lend structure and sophistication to the surfaces. Obsidian stands out for its intense deep black colour, while Material Silk is a delicate, pale, elegant shade. Both enhance volumes, lines and textures, ensuring project harmony and visual continuity.





The outdoor kitchen

L'acciaio inox satinato esprime precisione tecnica e affidabilità costruttiva. Il piano di lavoro, rinforzato con anima interna, garantisce stabilità dimensionale e resistenza alle sollecitazioni termiche e ambientali. La superficie compatta assicura igiene, pulizia immediata e una qualità estetica costante.

Satin-finish stainless steel represents technical precision and construction integrity. Reinforced with an inner core, the worktop guarantees dimensional stability and resistance to heat and environmental stress. Its compact surface ensures hygiene, immediate cleaning and constant aesthetic quality.

La serie Inox interpreta l'acciaio come materiale progettuale primario. Piano di lavoro, ripiani e lavello definiscono un linguaggio essenziale e rigoroso, basato su proporzioni, funzionalità e durata. Una soluzione che valorizza l'approccio tecnico di Fògher e rafforza l'identità architettonica del sistema cucina.

The Inox series features steel in the role of primary design material. Worktop, shelves and sink speak an essential meticulous language, based on proportions, function and durability. A solution that enhances the technical approach adopted by Fògher and reinforces the architectural identity of its kitchen system.



Lares

Il modulo Lares con barbecue ad incasso e carrello nasce per offrire una soluzione cucina compatta ed elegante, pensata per valorizzare anche gli spazi outdoor più contenuti. L'integrazione del sistema di cottura e l'equilibrio delle proporzioni definiscono un elemento autonomo, capace di unire qualità progettuale e comfort d'uso.

The Lares module with built-in barbecue and trolley has been created to offer a compact and elegant kitchen solution, designed to enhance even the most limited outdoor spaces. The integration of the cooking system and the balance of proportions define an autonomous element, capable of combining design quality and comfort of use.

Progettato per funzionare sia come elemento stand-alone sia come modulo integrabile all'interno della cucina Lares, il carrello amplia le possibilità compositive e operative. La flessibilità di utilizzo, unita al rigore formale e alle dimensioni controllate, consente un inserimento armonico in diversi contesti, garantendo continuità estetica e prestazioni affidabili.

Designed to function both as a stand-alone element and as an integrable module within the Lares kitchen, the trolley expands the compositional and operational possibilities. The flexibility of use, combined with rigor of the form and balanced dimensions, allows for harmonious insertion into different contexts, ensuring aesthetic continuity and reliable performance.



Plus della collezione



Piano di lavoro in acciaio Inox Stainless steel worktop

Modulare e altamente personalizzabile, la cucina Lares serie Inox è progettata per offrire la massima flessibilità progettuale. L'utilizzo esclusivo del metallo, con acciaio inossidabile AISI 316 per piano di lavoro, ripiani e lavello, garantisce resistenza, igiene e durabilità. Le superfici risultano facili da pulire e adatte anche a un utilizzo professionale, rendendo la serie Inox una soluzione affidabile e versatile per ogni contesto.

A highly customisable modular solution, the Lares Inox series kitchen has been conceived to offer maximum design flexibility. AISI 316 stainless steel is the only material used for worktop, shelves and sink, guaranteeing resistance, hygiene and durability. Also suitable for professional cooking, its easy-clean surfaces make the Inox series a reliable, versatile solution for any context.



Piano di lavoro in MDI MDI worktop

La cucina Lares serie MDI esprime una sintesi evoluta di personalizzazione, qualità e ricerca sui materiali. L'MDI è ottenuto attraverso un processo produttivo avanzato e sostenibile che utilizza minerali puri per creare superfici tecnicamente performanti, caratterizzate da una naturalezza unica al tatto e alla vista. La combinazione tra materiale, sistema modulare e finiture consente di progettare cucine su misura con un forte carattere estetico, perfettamente coerenti con lo stile dell'ambiente.

The Lares MDI series kitchen represents an advanced synthesis of customisation, quality and research into materials. MDI is the result of an advanced sustainable production process that uses pure minerals to create technically high-performing surfaces, naturally unique to the touch and the eye. Combining material, modular system and finishes enables the design of customised kitchens with strong aesthetics that fit perfectly into their intended setting.

Collection highlights



Gambe e struttura in acciaio inox verniciato Legs and structure in coated stainless steel

La struttura portante delle cucine Fògher è realizzata in acciaio verniciato, un materiale scelto per la sua elevata robustezza e resistenza alla corrosione. Questa soluzione consente l'installazione in ambienti esterni, assicurando stabilità e protezione dagli agenti atmosferici nel tempo.

The supporting structure of Fògher kitchens is in coated steel, extremely sturdy and corrosion resistant. This makes them suitable for outdoor installation and ensures long-lasting sturdiness and protection against the elements.



Piedini di regolazione estensibili Extendable adjustment feet

I piedini regolabili permettono un livellamento preciso dell'intera composizione cucina, anche su superfici irregolari. La base in gomma antiscivolo assicura un ancoraggio stabile al suolo, evitando spostamenti accidentali e garantendo sicurezza durante l'utilizzo.

Adjustable feet allow for precise levelling of the entire kitchen, even on uneven surfaces. The non-slip rubber ensures secure anchoring to the ground, preventing accidental movement and guaranteeing safety during use.

Plus della collezione

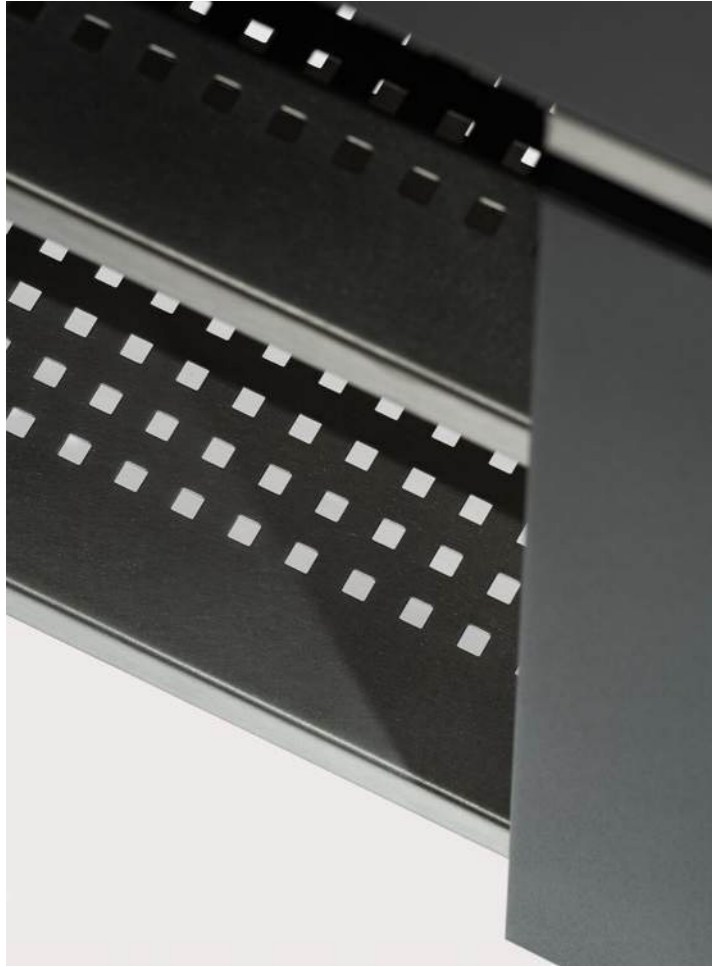

Ripiani in acciaio satinato rinforzato Reinforced satin-steel shelves

I ripiani delle cucine Fògher sono realizzati in acciaio satinato rinforzato e progettati per resistere a carichi elevati e all'utilizzo intensivo. Ricavati da un unico foglio di metallo piegato e lavorato, garantiscono solidità strutturale e, grazie alle perforazioni, un efficace deflussodell'acqua.

The shelves of Fògher kitchens are made in reinforced satin steel and designed to withstand heavy loads and intensive use. Made from a single sheet of machined bent metal, they guarantee sturdiness and efficient water drainage thanks to perforations.



Cerniere metalliche ad elevata resistenza Highly-resistant metal hinges

Le cerniere in acciaio Blum per ante a battente uniscono tecnologia avanzata e design riconosciuto a livello internazionale. Il meccanismo di ammortizzazione integrato nel fondello assicura una chiusura fluida e silenziosa, offrendo massimo comfort di utilizzo anche in spazi ridotti.

Blum steel door hinges combine innovative technology and internationally recognised design. The damper mechanism built into their backplate ensures soft silent closing and maximum performance even in small spaces.

Collection highlights



Carenature in metallo zinco-magnesio e acciaio Panels in zinc-magnesium metal and steel

Le carenature delle cucine Fògher nascono da leghe metalliche di alta qualità, in cui zinco e magnesio vengono combinati per garantire solidità, durata nel tempo e resistenza all'usura. Le ante a battente permettono di creare pratici vani chiusi per riporre utensili e accessori, favorendo al contempo composizioni dinamiche grazie all'alternanza di spazi chiusi e a giorno.

Fògher kitchen panels are forged from high-quality zinc-magnesium alloys to ensure long-lasting sturdiness, durability and resistance to wear and tear. Hinged doors create not only cupboard storage for utensils and accessories, but also dynamic compositions thanks to alternating open and closed spaces.



Appenderia Utensil rack

L'appenderia è un elemento funzionale ed estetico che caratterizza la linea Lares. Progettata per ospitare e organizzare gli strumenti di cottura, contribuisce a rendere lo spazio outdoor ordinato e operativo, aggiungendo al tempo stesso un segno distintivo e riconoscibile alla composizione cucina.

The utensil rack is a characteristic accessory of the Lares line that adds function and form. Designed to hold and organise cooking utensils, it helps to keep this outdoor kitchen tidy and operational, while adding a distinctive recognisable feature to this composition.

Plus della collezione



Snack bar Snack bar

Lo snack bar è disponibile in quattro dimensioni e offre una struttura funzionale pensata sia come piano di appoggio sia come zona conviviale. Con l'aggiunta degli sgabelli può essere utilizzato per consumare i pasti, mantenendo una profondità contenuta che ne facilita l'inserimento anche in spazi più compatti.

Available in four different sizes, the snack bar is a functional structure designed as both a work surface and a convivial area. With the addition of stools, it can be used at mealtimes, its narrow depth making it perfect even for smaller spaces.

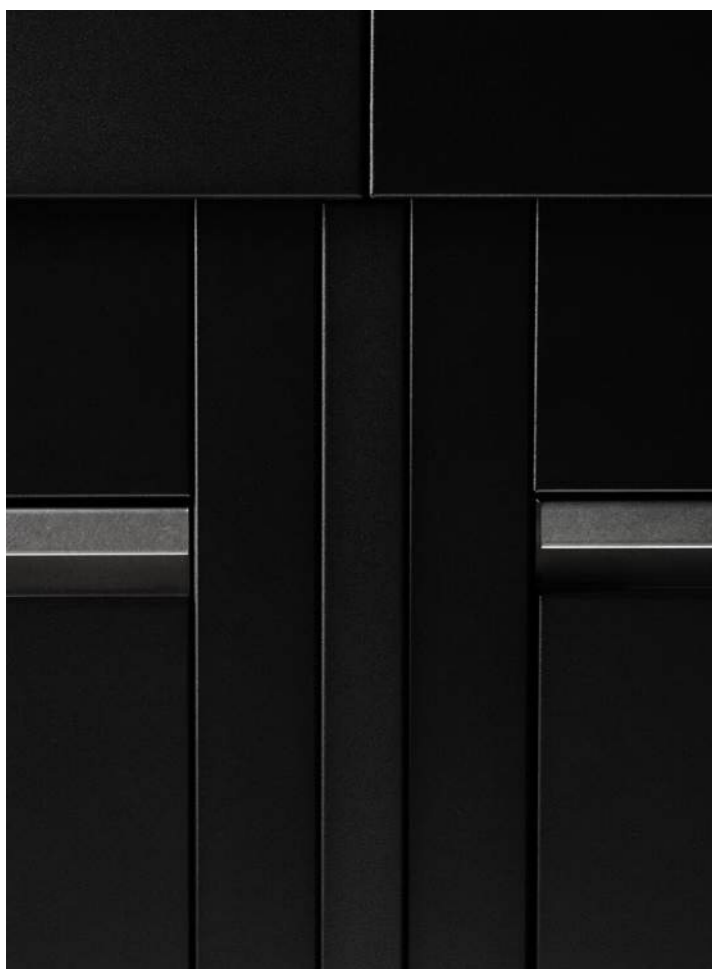

Kit giunzione Joining kit

Il kit giunzione è progettato per collegare i moduli cucina in modo solido e preciso, garantendo continuità strutturale e coerenza estetica. Questi elementi consentono di unire i diversi moduli in maniera stabile, contribuendo a rendere l'intera composizione più uniforme, robusta e perfettamente allineata.

The joining kit is designed as a solid, precise way of connecting the kitchen modules while guaranteeing seamless structural continuity and aesthetics. These elements enable the different modules to be firmly joined together, making the entire composition more even, sturdier, and perfectly aligned.

Collection highlights



Elettrodomestici

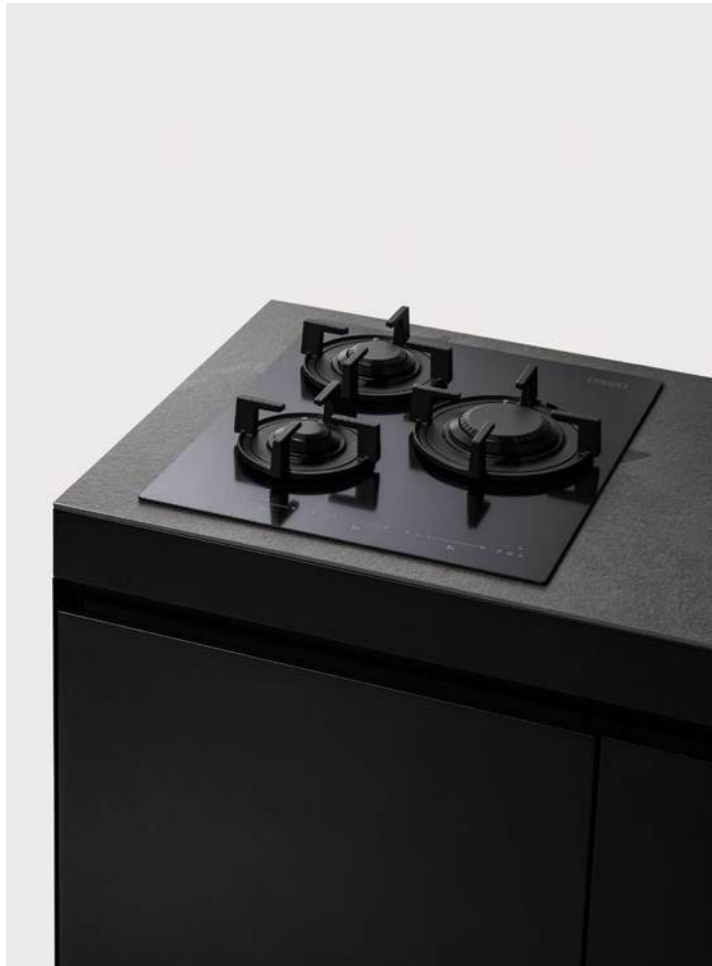

Piano cottura a gas Gas cooktop

I piani cottura a gas Fima sono disponibili nelle versioni a tre fuochi (FEF 4532 SE) e a un fuoco dual con accessorio wok (FEF 4514 SE). Progettati per l'uso outdoor, combinano la potenza del gas con un sistema di gestione elettronica touch che sostituisce le manopole tradizionali, migliorando ergonomia e affidabilità nel tempo. Il controllo intelligente della fiamma garantisce riaccensione automatica in caso di spegnimento accidentale, assicurando continuità di utilizzo, sicurezza e precisione durante ogni fase di cottura.

Fima gas cooktops are available as a three-burner (FEF 4532 SE) or dual-burner with wok support (FEF 4514 SE). Designed for outdoor use, they combine the power of gas with an electronic touch-control system instead of traditional knobs, improving ergonomics and reliability over time. Intelligent flame control guarantees that the flame is automatically reignited if accidentally extinguished, ensuring continuity of use safety and precision at each stage of cooking.



Piano cottura a induzione Induction cooktop

Il piano cottura a induzione Lùxar di Fògher interpreta la cucina outdoor attraverso un linguaggio essenziale e contemporaneo. La superficie in vetroceramica satinata integra tre zone di cottura in un unico piano continuo, dove la grafica discreta accompagna un'interazione intuitiva. Tecnologia e design si incontrano per offrire precisione, controllo e un'esperienza di cottura pulita e funzionale.

The Luxar induction cooktop by Fògher is an essential contemporary feature of the outdoor kitchen. A satin-finish glass-ceramic surface integrates three cooking zones in a single continuous cooktop, its discreet graphics teamed with intuitive interaction. Technology and design come together to deliver precision, control and a sleek functional cooking experience.

Appliances



Moduli refrigerazione Refrigerator modules

Il frigo-freezer ad incasso si integra con discrezione nelle cucine outdoor Agher, offrendo uno spazio refrigerato funzionale e un mini congelatore per maggiore versatilità. La cantinetta vini completa l'esperienza outdoor, mantenendo le bottiglie alla temperatura ideale e unendo funzionalità, stile e praticità in un'unica soluzione elegante e raffinata.

The built-in fridge-freezer fits seamlessly into Agher outdoor kitchens to offer practical refrigerated space and a mini freezer for greater versatility. The wine cellar completes the outdoor experience, keeping bottles at an ideal temperature while combining function, style and practicality in a single refined elegant solution.



Lavello in acciaio inox Stainless steel sink

Il lavello YÒZA 450 NA, installato sopra il top, è privo di vasca abbattibile, offrendo una struttura compatta e immediatamente disponibile. La configurazione semplificata consente un utilizzo diretto e intuitivo, garantendo resistenza, igiene e facilità di pulizia, con una resa estetica coerente con l'intero sistema cucina outdoor.

The over-mounted YÒZA 450 NA sink has no foldable Mixer tap, for an immediately available compact structure. Simplified configuration ensures direct intuitive use and guarantees resistance, hygiene, easy cleaning and aesthetics that match the entire outdoor kitchen system.

Sistemi di cottura

I sistemi di cottura Fògher rappresentano l'evoluzione tecnica del barbecue a gas, progettati per garantire prestazioni elevate e controllo preciso della temperatura. I modelli FGA e FGB trasformano il barbecue in un vero strumento di cucina, grazie a materiali selezionati, soluzioni costruttive avanzate e accessori dedicati, assicurando versatilità e risultati costanti.

Cooking system

Fògher cooking systems are the technical evolution of the gas barbecue, designed to guarantee high performance and precise temperature control. The FGA and FGB models transform the barbecue into a real kitchen tool, thanks to selected materials, advanced construction solutions and dedicated accessories, ensuring versatility and consistent results.

I sistemi di cottura Fògher sono progettati per offrire strumenti precisi e affidabili, con un controllo ottimale della temperatura e della distribuzione del calore. L'integrazione di materiali di alta qualità e accessori dedicati consente un utilizzo fluido, ergonomico e duraturo, garantendo prestazioni costanti nel tempo.

Fògher cooking systems are designed to offer precise reliable tools, with optimal control of temperature and heat distribution. The integration of high-quality materials and dedicated accessories allows for smooth, ergonomic, long-lasting use, ensuring constant performance over time.

I sistemi di cottura Fògher uniscono versatilità e prestazioni elevate in un unico strumento di cottura. La progettazione attenta dei materiali e delle soluzioni costruttive assicura stabilità, uniformità e affidabilità in ogni condizione, offrendo un'esperienza di cottura sicura, precisa e costantemente performante.

Fògher cooking systems combine versatility and high performance in a single tool. Careful design of materials and construction solutions ensures stability, uniformity and reliability in all conditions, offering a safe, precise, constantly high-performance cooking experience.



Barbecue FGA

I barbecue a gas FGA sono progettati per interpretare la cottura outdoor con un approccio essenziale e funzionale, in cui affidabilità tecnica e precisione costruttiva guidano il progetto. Pensati per la cottura diretta a gas, garantiscono una distribuzione uniforme del calore sulle superfici di cottura, offrendo controllo costante e risultati sempre omogenei.

FGA gas grills are designed to interpret outdoor cooking with an essential and functional approach where technical reliability and construction precision drive the project. Designed for direct gas cooking, they ensure even heat distribution on the cooking surfaces, offering constant control and consistent results.

Disponibili in diverse dimensioni e configurazioni di fuochi, possono essere installati come moduli integrati nei sistemi cucina outdoor oppure utilizzati in versione free standing, adattandosi con naturalezza a differenti contesti progettuali. Tutti i modelli sono progettati per essere facilmente inseriti in qualsiasi cucina Fògher, garantendo armonia stilistica e funzionale con il resto del sistema.

Available in various sizes and burner configurations, they can be installed as modules integrated into outdoor kitchen systems or used in a free-standing version, adapting naturally to different design contexts. All models are designed to fit easily into any Fògher kitchen, ensuring stylistic and functional harmony with the rest of the system.



Barbecue FGA FO

Il barbecue a gas FGA FO amplia le possibilità operative della cottura outdoor. Il coperchio multifunzione consente una gestione accurata della temperatura e rende possibile l'alternanza tra cottura diretta e indiretta, trasformando il barbecue in un sistema versatile e completo.

The FGA FO gas grill expands the operational possibilities of outdoor cooking. The multifunctional lid allows for accurate temperature management and makes it possible to alternate between direct and indirect cooking, transforming the barbecue into a versatile and complete cooking system.

La modularità delle superfici di cottura e la compatibilità con accessori dedicati permettono configurazioni flessibili e personalizzate. Disponibile in diverse misure, FGA FO può essere installato sia come elemento integrato sia in versione free standing, mantenendo coerenza formale e funzionale.

The modularity of the cooking surfaces and compatibility with dedicated accessories allow for flexible and customized configurations. Available in various sizes, FGA FO can be installed both as an integrated element and in a free-standing version, maintaining formal and functional consistency.



Barbecue FGB

Il barbecue a gas FGB è pensato per l'installazione ad incasso su piani di lavoro, offrendo una soluzione compatta e funzionale senza compromessi in termini di prestazioni. La struttura è studiata per garantire un efficace isolamento termico, riducendo la trasmissione del calore verso il piano di appoggio e preservando l'integrità dei materiali circostanti.

The FGB gas grill is designed for built-in installation on countertops, offering a compact and functional solution without compromising on performance. The structure is designed to ensure effective thermal insulation, reducing heat transmission to the support surface and preserving the integrity of the surrounding materials.

Questa impostazione consente un'integrazione sicura e armoniosa all'interno delle cucine outdoor. Tutti i modelli sono progettati per essere inseriti nelle cucine Fògher, garantendo continuità estetica e funzionale con gli altri moduli.

This setting allows for safe and harmonious integration within outdoor kitchens. All models are designed to be inserted into Fògher kitchens, ensuring aesthetic and functional continuity with the other modules.



Barbecue FGB FO

Il modello a gas FGB FO, dotato di coperchio multifunzione, amplia le possibilità di utilizzo, permettendo di gestire il calore in modo controllato e trasformando il barbecue in un vero e proprio forno outdoor.

The FGB FO gas model, equipped with a multifunction lid, expands the possibilities of use, allowing to manage the heat in a controlled way and transforming the barbecue into a real outdoor oven.

La progettazione dei flussi termici e la selezione dei materiali consentono l'installazione su diverse tipologie di piano di lavoro, evitando surriscaldamenti o deformazioni. FGB FO si inserisce così con eleganza e funzionalità nelle cucine, offrendo versatilità e praticità di utilizzo.

The design of the thermal flows and the selection of materials allow installation on different types of worktops, avoiding overheating or deformations. FGB FO thus fits elegantly and functionally into kitchens, offering versatility and ease of use.



Cottura diretta

Direct cooking

La cottura diretta è la classica grigliata in cui il cibo è a diretto contatto con la fonte di calore, con questo tipo di cottura si raggiungono temperature molto alte che permettono di cucinare velocemente diverse tipologie di pietanze, come carne, pesce e verdure.

Direct cooking is classic grilling with the food in direct contact with the heat source, the very high temperatures reached allowing rapid cooking of different kinds of food, such as meat, fish and vegetables.



Barbecue Barbecue



FGA 500 FGA 750 FGA 1000 FGA 500 FGA 750 FGB 1000



FGA 500 FO FGA 750 FO FGA 1000 FO FGB 500 FO FGB 750 FO FGB 1000 FO

Accessori di cottura Cooking accessories



Fry top Fry top Griglia doppia Double grill Pietra ollare Soapstone Brasiera Teppan

Cibo Dishes



Carne rossa Red meat Carne bianca White meat Pesce Fish Verdure Vegetables

Cottura indiretta

a media e alta temperatura

Indirect cooking at medium and high temperature

Nella cottura indiretta il cibo non è a diretto contatto con la fonte di calore, ma quest'ultimo viene riflesso dal coperchio coibentato all'interno della camera di cottura, trasformando il barbecue in un vero e proprio forno. Questo tipo di cottura richiede tempi più lunghi, ma consente di cucinare alimenti anche di grandi dimensioni, come arrostiti, pollame e dolci.

With indirect cooking, the food is not in direct contact with the heat source, as the latter is reflected by the insulated lid inside the cooking chamber that transforms the barbecue into a real oven. This kind of cooking takes longer, but makes it possible to cook even large pieces, such as roasts, chicken and cakes.



Barbecue Barbecue



FGA 500 FO FGA 750 FO FGA 1000 FO FGB 500 FO FGB 750 FO FGB 1000 FO

Accessori di cottura Cooking accessories



Fry top Fry top Griglia doppia Double grill Pietra ollare Soapstone Brasiera Teppan Kit cottura indiretta Indirect cooking kit

Cibo Dishes

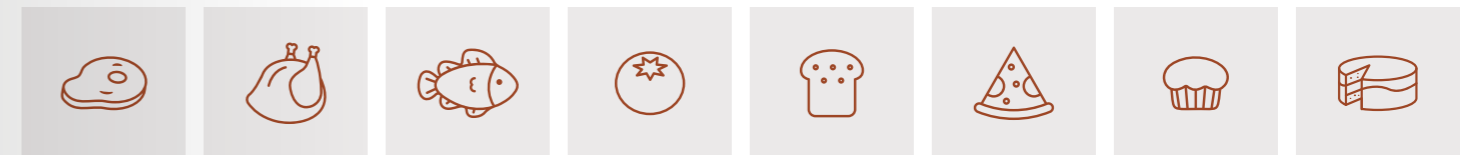

Carne rossa Red meat Carne bianca White meat Pesce Fish Verdure Vegetables Pane Bread Pizza Pizza Soufflé Soufflé Dolci Cakes



Cottura indiretta a bassa temperatura Affumicatura

Indirect cooking at low temperature Smoking

La cottura indiretta a bassa temperatura utilizza il coperchio come sistema di riflessione del calore ma sfrutta una temperatura più bassa all'interno della camera di cottura, è così possibile cucinare qualsiasi alimento, anche di grandi dimensioni o che richiede lunghe cotture. Inoltre attraverso l'apposito kit vi è la possibilità di aggiungere alle pietanze una nota affumicata grazie all'uso di chips di legni aromatici.

Indirect low-temperature cooking uses the lid as a heat reflection system but with a lower temperature inside the cooking chamber, making it possible to cook any kind of food, even large pieces or those requiring lengthy cooking times. A special kit also offers the possibility of adding a smoky note to the dishes with aromatic wood chips.



Barbecue Barbecue



FGA 500 FO



FGA 750 FO



FGA 1000 FO

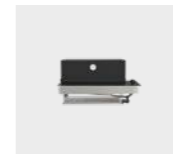

FGB 500 FO



FGB 750 FO



FGB 1000 FO

Accessori di cottura Cooking accessories



Fry top
Fry top



Griglia doppia
Double grill



Kit cottura indiretta
Indirect cooking kit

Cibo Dishes

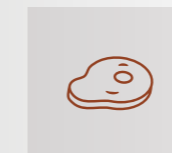

Carne rossa
Red meat

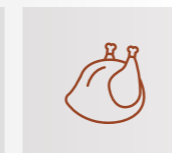

Carne bianca
White meat



Pesce
Fish

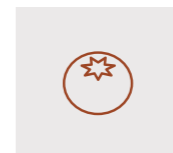

Verdure
Vegetables



L'esperienza
di barbecue definitiva

The ultimate
barbecue experience

Dettagli tecnici



Verniciatura resistente alle intemperie Weatherproof paint

Grazie alla verniciatura a polveri epossidiche termoindurenti e alla struttura in acciaio, i barbecue Fògher garantiscono una straordinaria resistenza alle alte temperature e agli eventi atmosferici, anche con il passare del tempo.

Thanks to their thermoset epoxy powder coating and steel structure, Fògher barbecues guarantee extraordinary resistance to high temperatures and the weather, even in the long term.

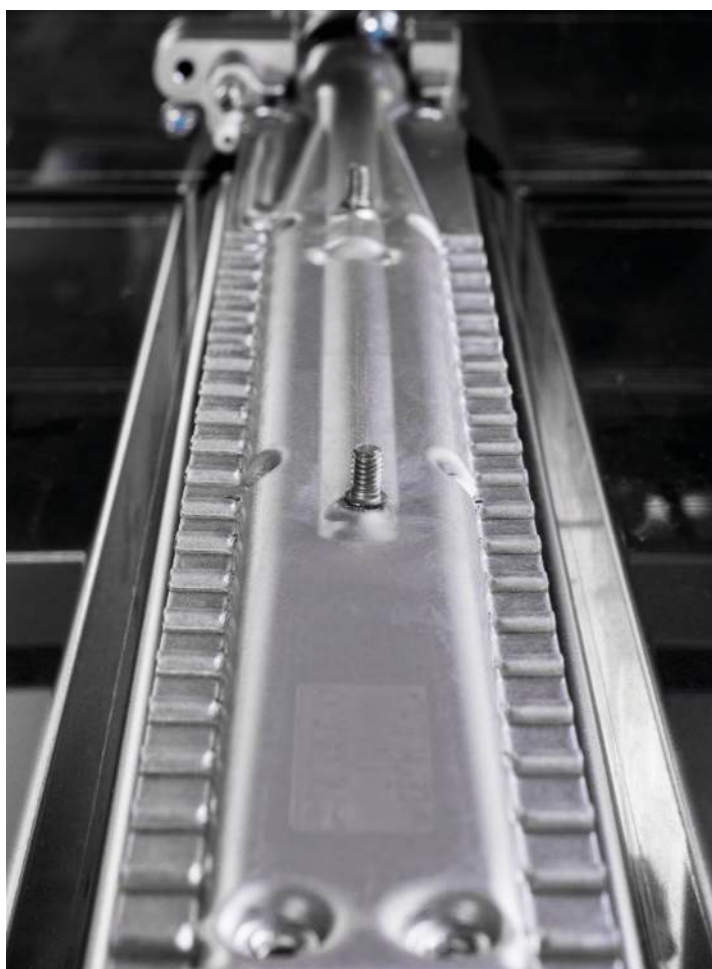

Bruciatori ad alta efficienza High efficiency burners

I bruciatori ad alte prestazioni con termocoppie di sicurezza native all'interno della struttura possono funzionare sia a GPL, sia a metano. Grazie all'efficiente sistema di propagazione del calore, i bruciatori riescono ad ottenere una potenza eccezionale con un risparmio di oltre 50% di gas rispetto ai competitors (2,8kW rispetto a 6kW).

High-performance burners with native safety thermocouples inside the structure can be used with both LPG and methane. Thanks to the efficient heat propagation system, the burners deliver exceptional power with savings in gas of over 50% compared to competitors (2.8kW compared to 6kW).

Technical details



Firecore®: propagazione ottimale del calore Firecore®: optimal heat propagation

La caratteristica principale dei barbecue a gas Fògher è il sistema Fire Core®. Questo esclusivo sistema di parabole radianti ottimizza il trasferimento di calore dal bruciatore alla piastra, distribuendolo in maniera uniforme su tutta la superficie di cottura. Ciò permette di cucinare con un notevole risparmio energetico.

The main feature of Fògher gas barbecues is their Fire Core® system. This exclusive system of radiant dishes optimises heat transfer from burner to griddle, ensuring even distribution over the entire cooking surface. This ensures considerable energy savings when cooking.



Cassetto recupero liquidi di cottura Drip pan for cooking liquids

Attraverso il nostro sistema di raccolta dei liquidi di cottura non sarà più necessario preoccuparsi dello sporco, infatti in ogni barbecue a gas Fògher è presente un pratico contenitore asportabile per la raccolta dei liquidi di colatura. In alternativa è possibile il montaggio di uno scarico per la raccolta direttamente negli appositi contenitori.

Our cooking liquid collection system makes worrying about dirt a thing of the past, as every Fògher gas barbecue features a practical removable drip pan. Alternatively, a drain hose can be fitted to drip directly into special containers.

Dettagli tecnici

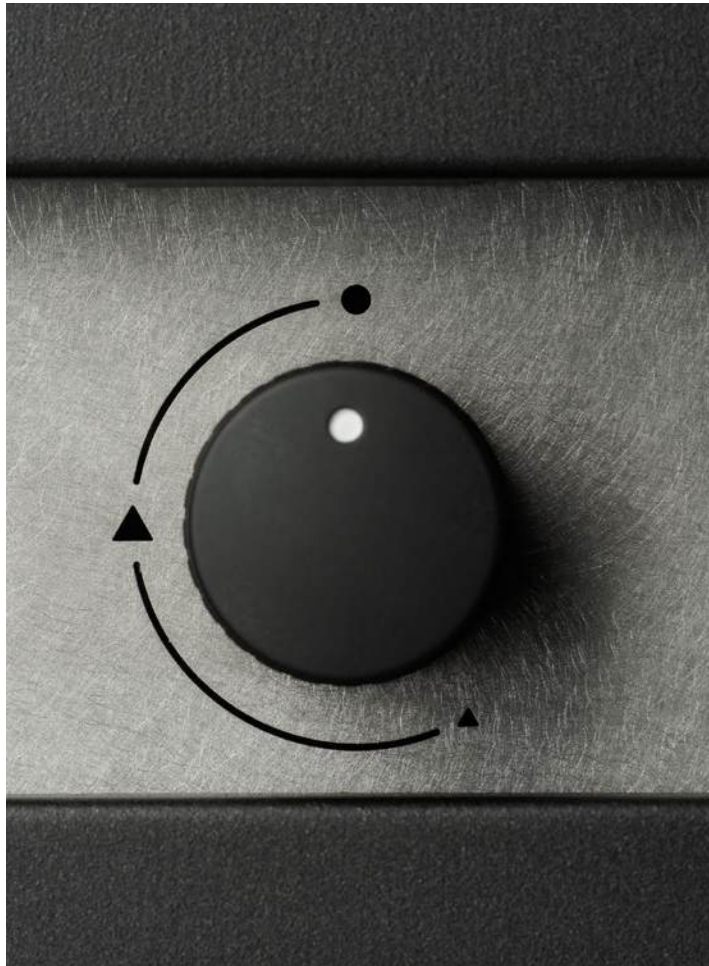

Manopola di precisione con 210° di rotazione Precision knob with 210° rotation

Con 210° di rotazione, rispetto ai 180° standard, le manopole di regolazione dei BBQ Fògher garantiscono una precisione ed un controllo della temperatura eccezionale, l'ideale anche per gli chef più esigenti.

Rotating 210° instead of the standard 180°, the knobs on Fògher BBQs guarantee exceptional precision and temperature control, ideal for even the most demanding chefs.



Superfici di cottura modulari Modular cooking surfaces

Grazie al sistema modulare le superfici di cottura dei BBQ sono intercambiabili e componibili a piacimento, infatti è possibile scegliere tra diversi complementi di cottura in base alle proprie esigenze. Tutte le piastre garantiscono inoltre uno scolo totale del grasso evitando la ricaduta nell'area dei bruciatori e mantenendo le superfici pulite per una cottura più salutare e una facile pulizia di tutti i componenti.

A modular system makes the BBQ cooking surfaces interchangeable so that they can be combined to suit personal requirements, with a wide choice of cooking accessories. All the plates also ensure total draining of grease, preventing it dripping onto the burner area and keeping surfaces clean for healthier cooking and easy cleaning of all components.

Technical details



Termometro con sonda integrata Thermometer with built-in probe

I barbecue della serie FGA-FO sono dotati di un termometro analogico con sonda integrata nel coperchio per permettere una supervisione totale durante la cottura dei cibi.

The FGA-FO series barbecues have an analogue thermometer complete with a probe fitted into the lid to allow complete control during cooking.



Coperchio multifunzione con isolamento Multifunction lid with insulation

Il coperchio termo isolato "cold cover" dei modelli FGA-FO è un vero e proprio strumento di cottura in grado di trasformare il barbecue in un forno. Questo sistema unito alla guarnizione permette una cottura con temperature eccezionalmente stabili garantendo anche una maggiore sicurezza durante l'utilizzo.

The thermo-insulated "cold cover" lid on the FGA-FO models is a real cooking tool that transforms the barbecue into an oven. Together with the gasket, this system enables cooking at exceptionally stable temperatures, also ensuring greater safety during use.

Dettagli tecnici



Sistema di estrazione dei fumi di combustione Combustion fume extraction system

L'innovativo sistema brevettato di estrazione dei fumi consente una cottura più salubre e genuina, eliminando i gas di combustione dalla camera di cottura attraverso il camino posizionato nella parte posteriore del coperchio.

An innovative patented fume extraction system allows for healthier, more genuine cooking, eliminating combustion gases from the cooking chamber through the chimney located at the back of the lid.



Cerniera calibrata con chiusura ammortizzata Calibrated soft-close hinge

L'apertura e chiusura del coperchio è resa estremamente agile grazie alla speciale cerniera calibrata. Grazie alle molle il peso percepito per alzare e abbassare il coperchio sarà di soli 500 g. Ciò, unito alla guarnizione, rende la chiusura leggera e ammortizzata.

Opening and closing the lid is extremely easy thanks to the special calibrated hinge. Springs mean that perceived weight when raising and lowering the lid is only 500 g. Together with the gasket, this makes for light soft closing.

Technical details

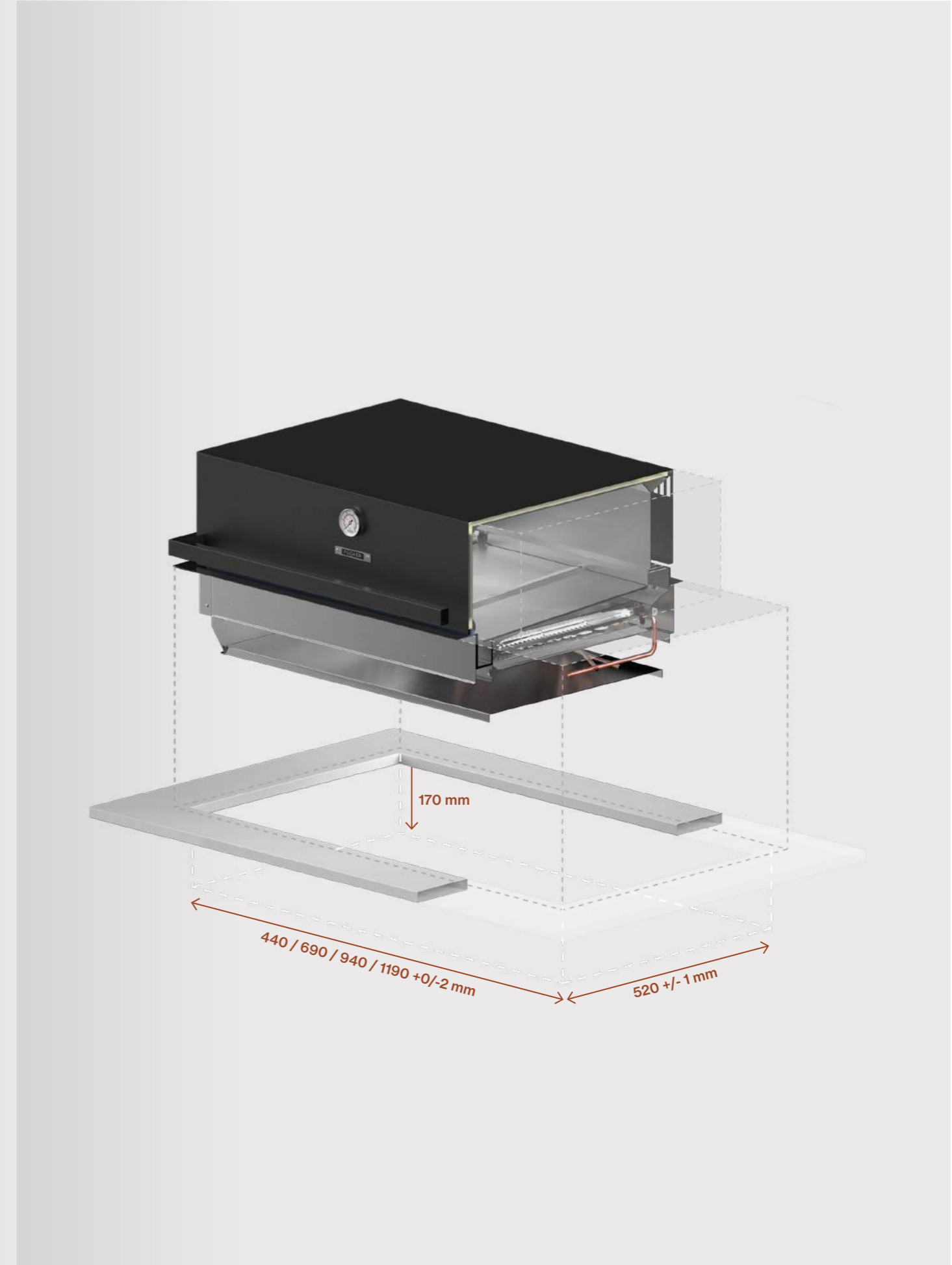

Accessori di cottura



Fry top in acciaio Steel fry top

La superficie di cottura in acciaio AISI 430 senza giunzioni garantisce prestazioni elevate. Grazie allo spessore maggiorato, mantiene il calore stabile più a lungo, riducendo il consumo di gas. È progettata specificamente per favorire il corretto deflusso dei liquidi di cottura.

The seamless AISI 430 steel cooking surface guarantees high performance. Thanks to its increased thickness, it keeps the heat even for longer, reducing gas consumption. It has been specifically designed to help cooking liquids drain off correctly.



Griglia doppia in acciaio Double steel grill

Una griglia ad estrazione totale scomponibile per facilitare la pulizia. La sua particolare struttura frangi fiamma garantisce una cottura con temperature corrette evitando che le fiamme entrino in contatto diretto con il cibo, eliminando così ogni tipo di bruciatura.

Fully extractable grill that can be taken apart for easy cleaning. Special flame guard structure. This ensures correct cooking temperatures by stopping the flames from coming into direct contact with the food, and eliminating any risk of burning.

Cooking accessories



Pietra ollare Soapstone

La pietra ollare piena con spessore di 20 mm consente una cottura sana della carne senza l'aggiunta di olio o burro, garantendo una distribuzione uniforme del calore.

Solid 20-mm-thick soapstone cooks meat healthily without the addition of oil or butter, ensuring even heat distribution.



Brasiera acciaio inox Stainless steel teppan grill

La brasiera in acciaio inox con spessore di 5 mm è progettata per garantire una cottura precisa e versatile. Adatta alla preparazione di carne, pesce e verdure, assicura una distribuzione uniforme del calore e un utilizzo agevole con qualsiasi utensile da cucina, grazie alla superficie ultra liscia.

The 5-mm-thick stainless steel teppan grill is designed to guarantee precise versatile cooking. Suitable for the preparation of meat, fish and vegetables, it ensures even heat distribution and easy use with any kitchen utensil, thanks to its ultra-smooth surface.

Accessori di cottura



Kit panificazione Baking kit

Il kit panificazione trasforma il barbecue in un vero e proprio forno per la preparazione di pane, pizza e altri alimenti panificati. Grazie al sistema di diffusione del calore e alla superficie in pietra refrattaria in cordierite, assicura un'eccellente trasmissione termica e raggiunge temperature comprese tra 350 e i 400°C, ideali per la cottura della pizza.

The baking kit transforms the barbecue into a real oven for cooking bread, pizza and other baked goods. Thanks to its heat diffusion system and cordierite refractory stone surface, it ensures excellent heat transmission and reaches temperatures of 662°F to 752°F, ideal for baking pizza.



Kit cottura indiretta e affumicatura low temperature cooking and smoker kit

Il kit per la cottura indiretta è composto da una griglia rialzata in acciaio inox che mantiene gli alimenti sollevati dalla fonte di calore diretta. Il kit include il contenitore per chips di legni aromatici, per arricchire le preparazioni con una delicata nota affumicata.

The indirect cooking kit consists of a raised stainless steel grill that keeps food away from the direct heat source. It also includes an aromatic wood chip holder to add an irresistible smoky note to dishes.

Cooking accessories



Smoker

Lo smoker Fògher porta la cucina a carbone a un livello professionale, disponibile in due versioni: Water Version o Reverse Flow. Progettato con materiali selezionati e soluzioni costruttive avanzate, combina innovazione e versatilità, garantendo un controllo ottimale del calore e dei fumi per risultati costanti e precisi in ogni preparazione.

Smoker

Taking charcoal cooking to professional levels, the Fògher smoker is available in two versions: Water Version or Reverse Flow. Designed with selected materials and advanced construction solutions, it combines innovation and versatility, ensuring optimal heat and fume control for constant precise results every time.

Lo smoker è dotato di FIRE CORE®, un sistema innovativo che schermando l'irradiazione termica del carbone permette una gestione precisa di fumi e calore tramite le serrande superiori e inferiori. Questa tecnologia assicura una distribuzione uniforme della temperatura nella camera di cottura, ottimizzando la consistenza e il sapore degli alimenti preparati.

The smoker is fitted with FIRE CORE®, an innovative system that shields the thermal radiation of the charcoal to allow accurate management of smoke and heat through the upper and lower shutters. This technology ensures even heat distribution in the cooking chamber for optimised food texture and flavour.

Il metodo Low & Slow consente una cottura lenta a basse temperature, tipica degli affumicatori, conferendo agli alimenti una consistenza morbida e aromi intensi. La costruzione in acciaio inox e le griglie regolabili garantiscono facilità di pulizia e manutenzione, mentre l'irradiazione costante della carbonella e l'uso di legni aromatici arricchiscono ogni ricetta con profumi unici.

The Low & Slow method allows for slow cooking at low temperatures typical of smokers, for tender food with intense flavour. The stainless steel construction and adjustable grills make cleaning and maintenance easy, while constant irradiation of the charcoal and the use of aromatic wood enrich each recipe with unique aroma.



Dettagli tecnici



Camino con presa d'aria in uscita regolabile Chimney with adjustable air vent

Le prese d'aria dotate di saracinesca regolabile permettono un controllo totale della quantità di ossigeno e fumo presenti nella camera di combustione e nella camera di cottura. Questo sistema tecnico assicura una gestione precisa del calore e della fumosità, consentendo di ottenere risultati di cottura ottimali e uniformi, anche durante sessioni prolungate.

The air vents with adjustable shutters allow total control of the amount of oxygen and smoke in the combustion and cooking chambers. This technical system ensures precise heat and smoke management, for optimal uniform cooking results, even during lengthy sessions.

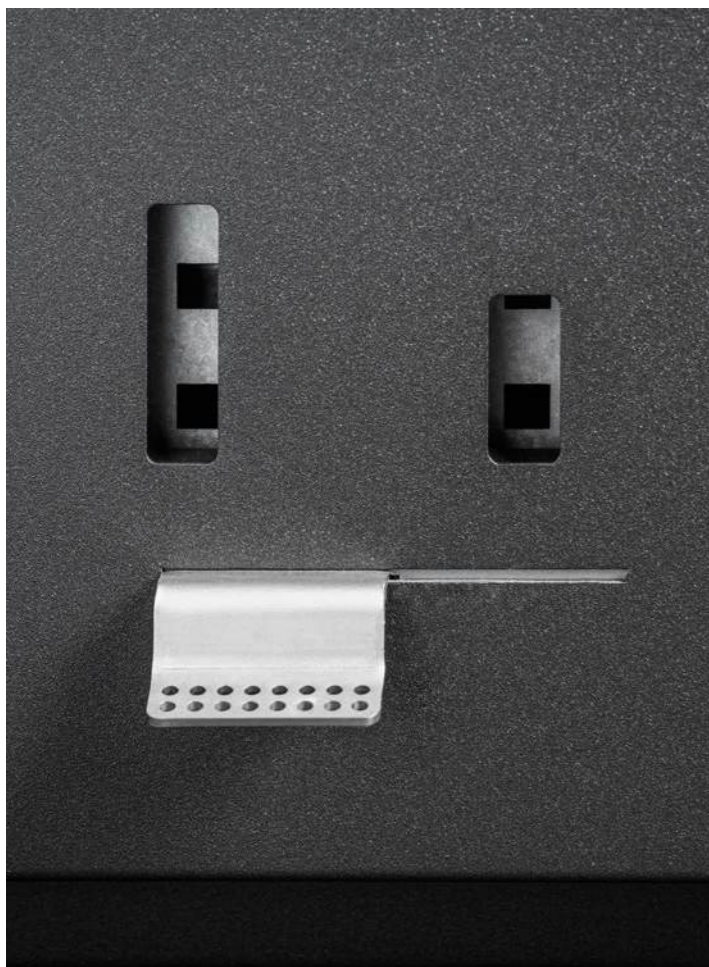

Presca d'aria in entrata regolabile Adjustable air intake

La presa d'aria inferiore dello smoker Fògher consente l'immissione controllata di aria nella camera di combustione, alimentando le braci e modulando con precisione il calore generato. Grazie alla saracinesca regolabile, è possibile gestire il flusso d'aria in modo accurato, ottimizzando la combustione e garantendo temperature costanti per cotture uniformi e controllate.

"The lower air intake of the Fògher smoker controls the intake of air into the combustion chamber, to feed the coals and accurately modulate the heat generated. The adjustable shutter allows for accurate management of the air flow, optimising combustion and ensuring constant temperatures for uniform controlled cooking.

Technical details



Camera di cottura in acciaio inox Stainless steel cooking chamber

La camera di cottura è realizzata in acciaio inossidabile AISI 304, assicurando una struttura robusta e resistente alla corrosione. Questo materiale garantisce igiene e sicurezza alimentare, evitando contaminazioni, e rende la pulizia semplice e rapida, mantenendo la camera sempre pronta per l'uso.

The cooking chamber is made of AISI 304 stainless steel, ensuring a robust, corrosion-resistant structure. This material guarantees hygiene and food safety, avoiding contamination, for easy rapid cleaning that means the chamber is always ready for use.



Scocca coibentata Insulated body

La scocca coibentata dello smoker Fògher garantisce un isolamento termico efficace, distribuendo il calore in maniera uniforme all'interno della camera di cottura. Questo migliora la qualità della cottura, evita punti troppo caldi o freddi e riduce il consumo di carbone, aumentando l'efficienza complessiva del sistema.

The insulated body of the Fògher smoker guarantees effective thermal insulation, distributing the heat evenly inside the cooking chamber. This improves cooking quality, avoids hot or cold spots, and reduces charcoal consumption, increasing the overall efficiency of the system.

Dettagli tecnici



Camera di combustione con serpentina Combustion chamber with coil

La camera di combustione dello smoker Fògher è il cuore del sistema, dove calore e fumo vengono generati per cucinare gli alimenti. La serpentina integrata ottimizza l'efficienza energetica, permettendo di mantenere elevate prestazioni di cottura riducendo il consumo di combustibile, per risultati uniformi e costanti.

The combustion chamber of the Fògher smoker is the heart of the system, where heat and smoke are generated to cook food. The integrated coil optimises energy efficiency, maintaining excellent cooking results while reducing charcoal consumption, for consistent uniform results.



Water pan Water pan

La water pan è un elemento essenziale del sistema di cottura: consente di aggiungere acqua per stabilizzare la temperatura, riducendo gli sbalzi improvvisi e garantendo maggiore costanza. Allo stesso tempo aumenta l'umidità interna, limita la disidratazione della carne e favorisce una migliore adesione del fumo nelle prime fasi di cottura, per risultati più morbidi e uniformi.

The water pan is an essential component of the cooking system: it allows water to be added to stabilize the temperature, reducing sudden fluctuations and ensuring greater consistency. At the same time, it increases internal humidity, limits meat dehydration, and promotes better smoke adhesion during the initial stages of cooking, delivering softer and more uniform results.

Technical details



Guarnizione termica di tenuta Thermal seal gasket

La guarnizione di tenuta termica dello smoker Fògher garantisce un'efficace conservazione del calore all'interno della camera di cottura, migliorando la stabilità e l'uniformità delle temperature durante l'intero processo di cottura. Questo componente ottimizza l'efficienza energetica e contribuisce a risultati costanti e precisi.

The thermal seal gasket on the Fògher smoker guarantees effective heat retention inside the cooking chamber, for more stable, uniform temperatures during the cooking process. This component optimises energy efficiency for consistent, accurate results.



Ripiani alimenti Food shelves

Lo smoker Fògher supporta fino a sei ripiani all'interno della camera di cottura, tutti compatibili con accessori Gastro Norm $\frac{2}{3}$, per una gestione modulare degli alimenti. Il prodotto include due griglie in acciaio inossidabile AISI 304, garantendo igiene, resistenza alla corrosione e prestazioni costanti anche durante cotture prolungate.

The Fògher smoker can hold up to six shelves inside the cooking chamber, all compatible with Gastro Norm $\frac{2}{3}$ accessories for modular management of food. The product includes two AISI 304 stainless steel racks, ensuring hygiene, corrosion resistance and consistent performance even during lengthy cooking.

Dettagli tecnici



Termometro analogico con sonda integrata Analogue thermometer with built-in probe

Il termometro analogico con sonda integrata nella camera di cottura permette di monitorare con precisione la temperatura durante l'intero processo di cottura. Per chi desidera un controllo ancora più accurato, lo smoker Fògher prevede inoltre predisposizioni per l'installazione di sonde esterne.

The analogue thermometer with a probe fitted into the cooking chamber allows precise temperature control during cooking. For those who want even more accurate control, the Fògher smoker can also be retrofitted with external probes.



Chiusura a leva Toggle latch

La chiusura a leva, robusta e intuitiva da azionare, è un elemento centrale di ogni smoker Fògher. Assicura massima sicurezza durante l'uso e una gestione semplice e immediata.

Sturdy and easy to use, the toggle latch is a central element of every Fògher smoker. It ensures maximum safety during use and simple and immediate control.

Technical details



Cassetta raccolta cenere Ash box

Cassetta raccogli cenere integrata per una pulizia semplice e rapida, che evita la dispersione di residui nell'ambiente. Lo smoker resta sempre ordinato e pronto all'uso, per un'esperienza di cottura pratica e funzionale.

Quick and easy to clean, the built-in ash box prevents the dispersal of residue into the environment. The smoker is always clean and ready to use, for a practical functional cooking experience.



Piedini d'appoggio regolabili Adjustable feet

I piedini d'appoggio regolabili assicurano una stabilità ottimale dello smoker su qualsiasi superficie, anche irregolare come erba, ghiaia o roccia. Questo sistema permette un posizionamento sicuro e preciso, garantendo comfort d'uso e performance costanti durante tutte le sessioni di cottura.

The adjustable feet ensure optimal stability for the smoker on any surface, even uneven ones such as grass, gravel or rock. This system allows for safe precise positioning, ensuring ease of use and constant performance during all cooking sessions.

Dettagli tecnici

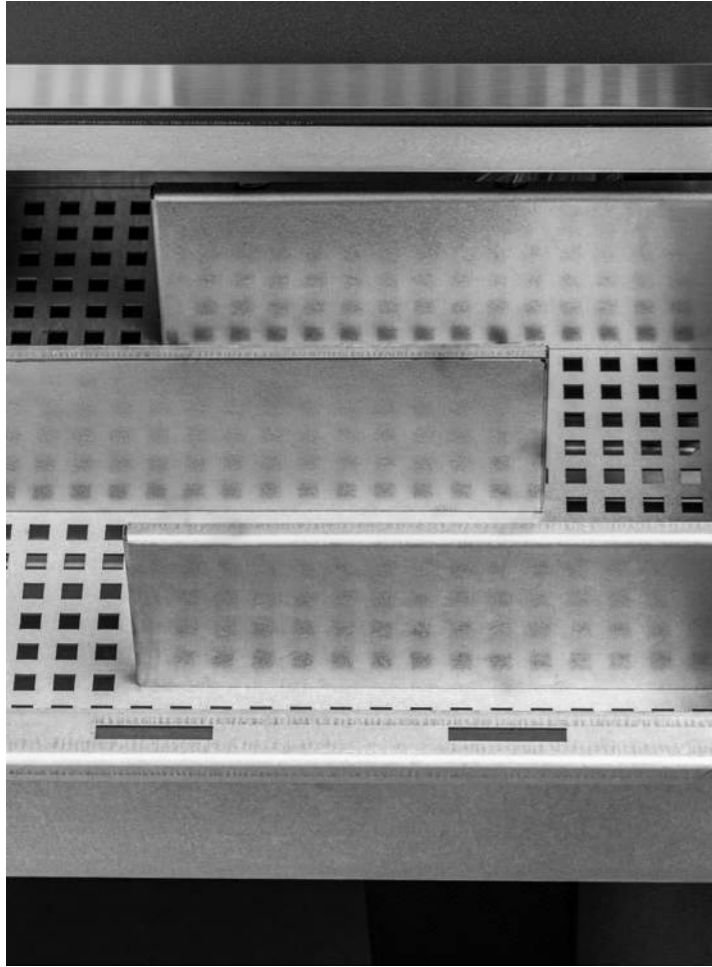

Fornace per 2 kg max di carbone Furnace for up to 2 kg of coal

La fornace dello smoker Fògher può contenere fino a 2 kg di carbone, garantendo cotture prolungate senza interruzioni per ricariche, per risultati costanti anche durante sessioni lunghe.

The Fògher smoker furnace can hold up to 2 kg of charcoal, for prolonged cooking with no interruptions for refilling, giving constant results even during lengthy sessions.



Predisposizione per ventola di controllo Retrofitting with heat control fan

Tutti i nostri affumicatori sono predisposti per l'installazione di una ventola di controllo automatico del calore. Questo sistema regola il flusso d'aria nella camera di combustione, consentendo di mantenere costante la temperatura e garantendo una cottura uniforme degli alimenti.

All our smokers can be retrofitted with an automatic heat control fan. This system regulates the airflow in the combustion chamber, maintaining a constant temperature and ensuring the food is cooked evenly.

Technical details



Caminetto

Il caminetto grill Fògher interpreta il fuoco come elemento centrale della convivialità outdoor. La cottura su brace, generata naturalmente dalla legna, esalta profumi e sapori autentici, creando un'esperienza che coinvolge i sensi. Progettato per adattarsi a diversi spazi esterni, unisce praticità e libertà di utilizzo. Le forme essenziali e le finiture contemporanee lo rendono un oggetto capace di dialogare con l'ambiente, trasformando ogni momento all'aperto in un rituale condiviso.

Fireplace

The Fògher fireplace grill embodies fire as a central element of outdoor conviviality. Cooking over embers, naturally generated by wood, enhances authentic aromas and flavours, creating an experience that engages the senses. Designed to adapt to different outdoor spaces, it combines practicality and freedom of use. Its essential shapes and contemporary finishes make it capable of dialoguing with its surroundings, transforming every moment spent outdoors into a shared ritual.

Il caminetto grill Fògher è progettato per garantire prestazioni affidabili e facilità d'uso negli ambienti outdoor. Utilizzabile con legna, carbone o bricchette, assicura una gestione efficiente della brace e una cottura uniforme. La struttura è composta da elementi modulari che ne facilitano l'integrazione con i sistemi cucina Fògher. Materiali resistenti, finiture curate e produzione 100% Made in Italy definiscono un prodotto solido, funzionale e pensato per durare nel tempo.

The Fògher fireplace grill is designed to ensure reliable results and ease of use in outdoor environments. It can be used with wood, charcoal or briquettes and ensures efficient control of the embers and uniform cooking. The structure is made up of modular elements that facilitate integration with the Fògher kitchen systems. Resistant materials, refined finishes and production 100% Made in Italy define a solid, functional product designed to last over time.

Pensato per vivere l'esterno in modo naturale e spontaneo, il caminetto grill Fògher diventa il punto focale dello spazio. Il fuoco, visibile e reale, accompagna la preparazione dei cibi e crea un'atmosfera calda e accogliente. La struttura leggera e facilmente riposizionabile consente massima flessibilità d'uso, mentre il design geometrico e pulito ne valorizza l'integrazione anche all'interno di sistemi cucina modulari. Un equilibrio perfetto tra estetica e funzione.

Conceived to offer a natural spontaneous outdoor experience, the Fògher fireplace grill becomes the focal point of any space. Visible and real, the fire accompanies food preparation and creates a warm welcoming atmosphere. Lightweight and easy to move, the structure allows maximum flexibility of use, while its geometric no-frills design means it fits perfectly into modular kitchen systems. The perfect balance of form and function.



Dettagli tecnici



Doppia cappa per evitare il surriscaldamento Double hood to prevent overheating

Gli approfonditi studi di fluidodinamica alla base della progettazione della cappa hanno consentito lo sviluppo di un sistema capace di garantire un'elevata efficienza di aspirazione in ogni condizione atmosferica. La struttura integra una camera d'aria ventilata, studiata per favorire la dissipazione del calore generato internamente, contribuendo a mantenere inalterate nel tempo le prestazioni, la resistenza dei materiali e la qualità estetica della superficie esterna.

The in-depth study of fluid dynamics behind the design of this hood has enabled development of a system that guarantees highly efficient suction in all weather conditions. Its structure has a ventilated air chamber studied to dissipate the heat generated internally, helping to maintain performance, the materials' resistance and external surface aesthetics over time.



Canalina di scolo per le acque piovane Rainwater drainage channel

La canalina di scolo delle acque piovane convoglia l'acqua lontano dalla zona di cottura, proteggendo le superfici operative, prevenendo accumuli di umidità e corrosione, e garantendo affidabilità, sicurezza e continuità d'uso anche in condizioni atmosferiche avverse.

The channel drains rainwater away from the cooking area, protecting the surfaces, preventing an accumulation of humidity and corrosion and guaranteeing reliability, safety and continual use even in bad weather.

Technical details

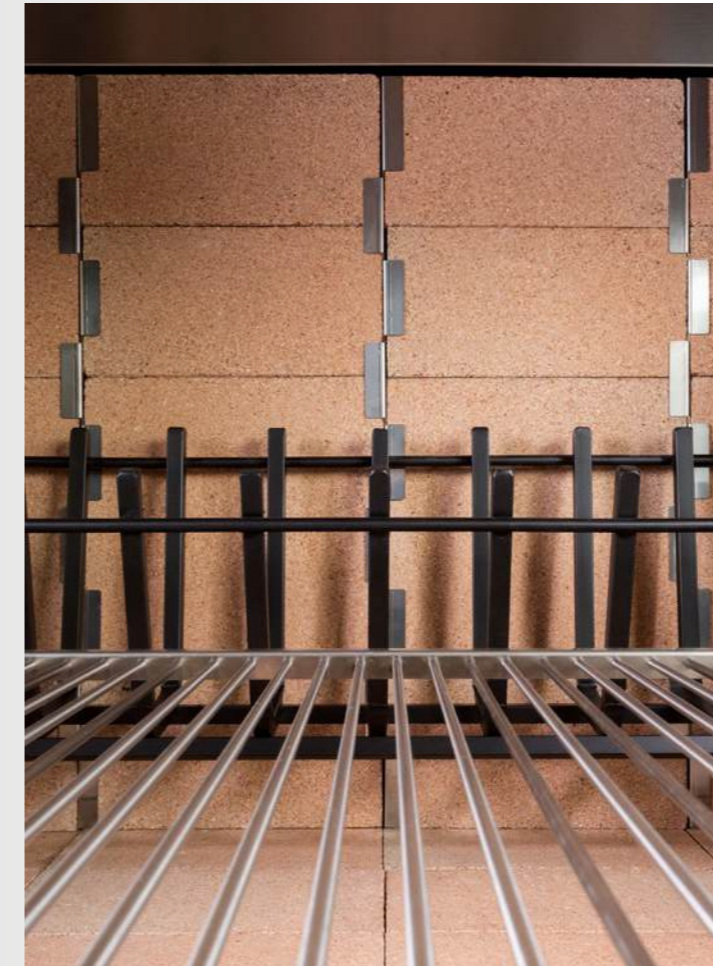

Rivestimento interno in mattoni refrattari Refractory brick interior cladding

Il caminetto grill da giardino utilizza mattoni refrattari posizionati sul piano di cottura a diretto contatto con la fiamma, capaci di trasferire alla struttura stabilità termica e resistenza alle alte temperature. Facili da sostituire, sono montati con giunti di dilatazione studiati per prevenire crepe e deformazioni, garantendo sicurezza e lunga durata anche in uso continuativo.

The garden fireplace grill has refractory bricks on the cooktop in direct contact with the flames, making the structure thermally stable and resistant to high temperatures. Easy to replace, they are assembled with expansion joints to prevent cracks and breaks, guaranteeing safety and long-term durability even with continuous use.

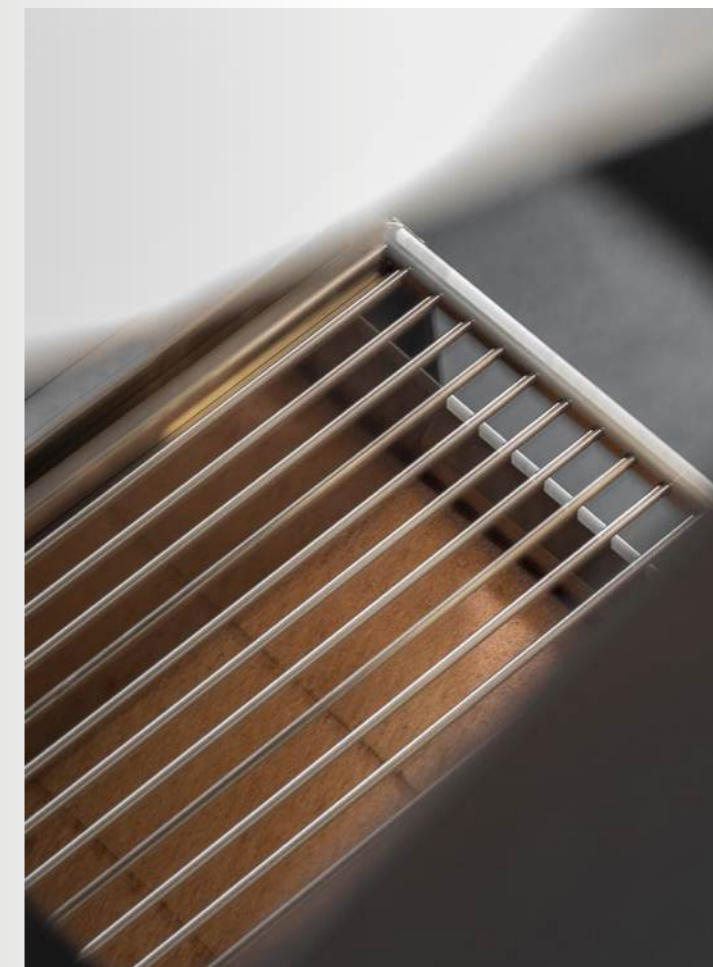

Griglia cottura a tondini in acciaio inox Cooking grill made from stainless steel rods

La griglia a tondini, fornita con il caminetto grill da giardino, è realizzata completamente in acciaio inossidabile ad alta resistenza termica. Non corrosibile, mantiene le caratteristiche meccaniche e la superficie liscia nel tempo, garantendo una cottura uniforme e risultati costanti anche dopo un uso prolungato.

The garden fireplace grill comes with a rod grill made entirely of stainless steel with high thermal resistance. Non-corrodible, it maintains its mechanical characteristics and smooth surface over time, ensuring uniform cooking and constant results even after prolonged use.

Dettagli tecnici



Verniciatura resistente alle intemperie Weatherproof paint

La superficie esterna del caminetto è trattata con una speciale verniciatura a polveri, che unita allo spessore elevato della scocca, assicura eccellente resistenza agli agenti atmosferici. In questo modo, il caminetto Fògher mantiene nel tempo prestazioni costanti e affidabili.

The external surface of the fireplace is treated with a special powder coating, which, combined with the very thick body, ensures excellent resistance to the elements. This means that the Fògher fireplace maintains a constant reliable performance over time.



The outdoor kitchen

Scocca in zinco magnesio Zinc-magnesium shell

La scocca del caminetto, realizzata in una lega metallica a base di zinco e magnesio, combina leggerezza e solidità. Resistente all'usura e agli agenti esterni, mantiene nel tempo integrità e stabilità, garantendo durata e sicurezza anche dopo un uso prolungato.

The fireplace shell is lightweight yet solid, thanks to a metal zinc-magnesium alloy. Resistant to wear and external agents, it remains integral and stable over time, ensuring durability and safety even after prolonged use.

P.130

Technical details



Fireplace

P.131

Informazioni tecniche

Dati dimensionali, configurazioni e specifiche tecniche definiscono le caratteristiche dei sistemi Fògher, fornendo gli elementi necessari alla corretta progettazione e integrazione dei prodotti negli spazi outdoor. Le informazioni sono sviluppate nel rispetto degli standard qualitativi del brand, a supporto della coerenza funzionale ed estetica dell'intero sistema.

Technical information

Dimensional data, configurations, and technical specifications define the characteristics of Fògher systems, providing the elements necessary for proper design and integration within outdoor spaces. The information is developed in accordance with the brand's quality standards and supports the functional and aesthetic coherence of the entire system.

Nojara, la cucina-tavolo

Nojara, the kitchen-table

Nojara distingue le aree funzionali della cucina, permettendo di configurare separatamente piani di lavoro, zone cottura e superfici conviviali. Questa modularità consente di scegliere finiture, materiali e disposizione dei singoli elementi in base al progetto, garantendo un risultato personalizzato, coerente e funzionale in ogni spazio outdoor.

Nojara distinguishes the functional areas of the kitchen, enabling separate configuration of worktops, cooking areas, and convivial surfaces. This modularity allows selection of finishes, materials, and arrangement of individual elements according to project requirements, ensuring a functional, coherent, and customized solution for every outdoor space.

Configurazioni

Configurations

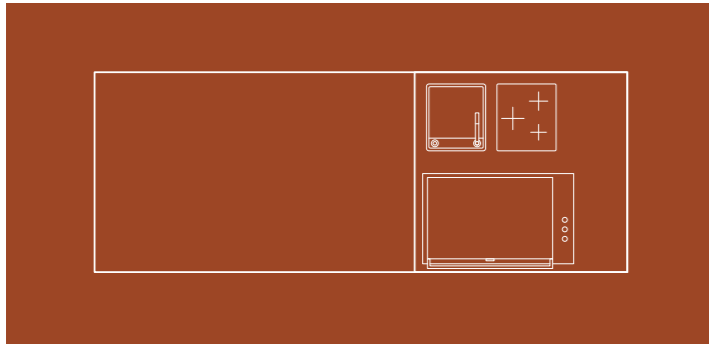

3995 x 1500 mm
157 ¼ x 59 ⅞ in

Nojara è un sistema modulare per l'outdoor di 3995 x 1500 mm, progettato per integrare in un'unica struttura superfici di lavoro, cottura e convivialità. I moduli possono essere combinati e configurati secondo le specifiche del progetto, ottimizzando flussi operativi, ergonomia e distribuzione dello spazio.

Nojara is a 3995 x 1500 mm (157 ¼ x 59 ⅞ in) modular outdoor system, designed to integrate work surfaces, cooking areas, and convivial zones into a single structure. The modules can be combined and configured according to project specifications, optimizing operational flows, ergonomics, and space distribution.

Area cooking

Cooking area

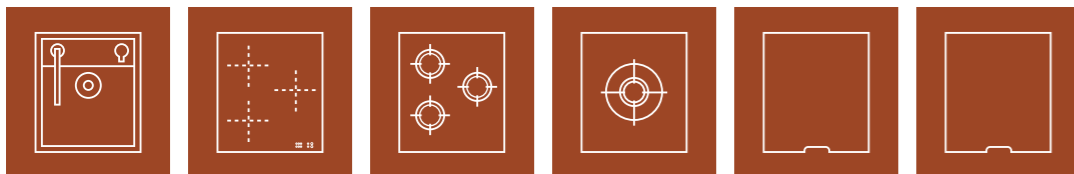

Lavello
Sink

Induzione
Induction

Gas 3 fuochi
3 burners gas

Gas 1 fuoco dual
1 dual burner gas

Copri foro MDI
MDI cover plate

Tagliere Corian®
Corian® cutting board

Sistemi di cottura Fògher

Fògher cooking systems

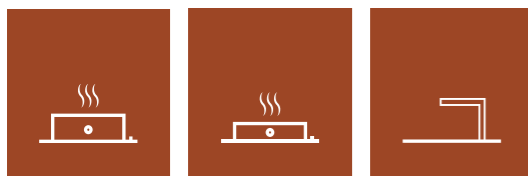

BBQ a gas ad incasso con coperchio forno
Built-in gas BBQ with oven lid

BBQ ad incasso a gas con coperchio basso
Built-in gas BBQ with low lid

FEY 950 ST
Sistema lavello Yòza
FEY 950 ST
Yòza sink system

Materiali e finiture

Materials and finishes

Nojara adotta un approccio funzionale alla personalizzazione, distinguendo le finiture in base alle diverse aree operative della cucina. Questa suddivisione consente di intervenire in modo mirato sui singoli elementi, offrendo flessibilità progettuale e controllo estetico complessivo.

Nojara adopts a functional approach to customization, distinguishing finishes according to the different functional areas of the kitchen. This structure allows for targeted intervention on individual elements, offering design flexibility and overall aesthetic control.

Area cottura

Cooking area

Base Base



Ossidiana
Obsidian

Seta Materica
Material Sink

Piano Top

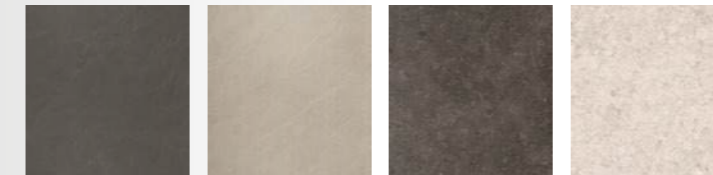

MDI pacific gris
MDI pacific gris

MDI pacific blanco
MDI pacific white

Roccia bruna
Dark rock

Duna chiara
Light dune

Tavolo

Table

Base Base



Ossidiana
Obsidian

Bronzo vivo
Live bronze

Terra di Siena
Sienna

Soffio di Baia
Bay breeze

Salvia Antica
Ancient Sage

Seta Materica
Material Sink

Piano Top

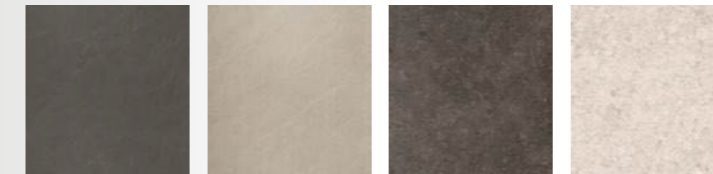

MDI pacific gris
MDI pacific gris

MDI pacific blanco
MDI pacific white

Roccia bruna
Dark rock







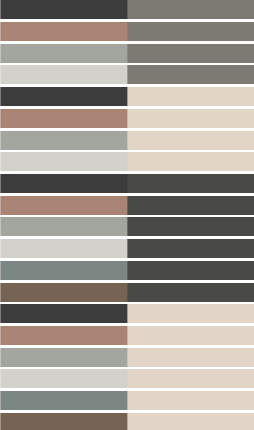

Duna chiara
Light dune

Codici di riferimento Nojara



Prodotto Product	Nome prodotto Product name	Misure (LxPxA) mm Measures (LxDxH) in	Finitura Finishing	Codice Code
	Modulo area cottura Cooking area module	1595 x 1500 x 910 mm 62 ³ / ₄ x 59 ¹ / ₈ x 35 ³ / ₄ in		1088818.0-N201 1088818.0-N205 1088818.0-N101 1088818.0-N105 1088818.0-N401 1088818.0-N405 1088818.0-N301 1088818.0-N305



	Tavolo Nojara da 8 persone Nojara table for 8 people	2400 x 1500 x 910 mm 94 ¹ / ₂ x 59 ¹ / ₁₆ x 35 ³ / ₁₆ in		1088819.0-N201 1088819.0-N202 1088819.0-N204 1088819.0-N205 1088819.0-N101 1088819.0-N102 1088819.0-N104 1088819.0-N105 1088819.0-N401 1088819.0-N402 1088819.0-N404 1088819.0-N405 1088819.0-N409 1088819.0-N403 1088819.0-N301 1088819.0-N302 1088819.0-N304 1088819.0-N305 1088819.0-N309 1088819.0-N303
--	--	--	--	--

Elettrodomestici Appliances



	FEL 453 ST Piano cottura induzione Lùxar 3 zone FEL 453 ST Lùxar Induction cooktop 3 zones	450 x 520 mm 17 ³ / ₄ x 20 ¹ / ₂ in		1084215.1*
	FEF 4514 SE Piano cottura gas Fiamo 1 fuoco dual FEF 4514 SE Fiamo gas cooktop 1 dual burner	450 x 520 mm 17 ³ / ₄ x 20 ¹ / ₂ in		1084508.1*
	FEF 4532 SE Piano cottura gas Fiamo 3 fuochi FEF 4532 SE Fiamo gas cooktop 3 burners	450 x 520 mm 17 ³ / ₄ x 20 ¹ / ₂ in		1084501.1*
	FEY 450 NA Lavello Yòza FEY 450 NA Yòza Sink	440 x 510 mm 17 ³ / ₈ x 20 ¹ / ₈ in		1089742.0

Nojara key codes

Prodotto Product	Nome prodotto Product name	Misure (LxPxA) mm Measures (LxDxH) in	Finitura Finishing	Codice Code
	FEY 450 UT Lavello Yòza FEY 450 UT Yòza Sink	440 x 500 mm 17 ³ / ₈ x 19 ⁵ / ₈ in		1084796.0

	FEY 950 ST Sistema lavello Yòza FEY 950 ST Yòza Sink System	970 x 530 x 230 mm 38 ³ / ₁₆ x 20 ⁷ / ₈ x 9 in		1084797.0
---	---	--	---	-----------

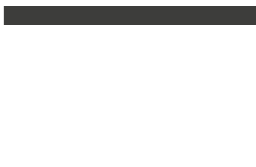

Sistemi di cottura ad incasso FGB FGB built in cooking systems

	Sistema di cottura FGB 750 FGB 750 built-in cooking system	963 x 575 x 217 mm 37 ⁷ / ₈ x 22 ³ / ₄ x 8 ¹ / ₂ in		1085771.1*
---	--	---	---	------------

	Sistema di cottura FGB 750 FO FGB 750 FO built-in cooking system	963 x 615 x 382 mm 37 ⁷ / ₈ x 24 ¹ / ₄ x 15 in		1085772.1*
---	--	--	---	------------

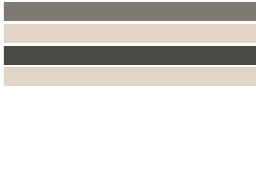
Accessori copri foro Cut out cover accessories

	Vaschetta sotto top con copri fori in ceramica super sinterizzata Under-counter tray with ultra-sintered ceramic hole cover plate	420 x 480 mm 16 ¹ / ₂ X 18 ³ / ₈ in		1088812.0-N200 1088812.0-N100 1088812.0-N400 1088812.0-N300
---	---	---	---	--

	Copri lavello in ceramica super sinterizzata Yòza FEY 450 UT Ultra-sintered ceramic Yòza FEY 450 UT sink cover	420 x 480 mm 16 ¹ / ₂ X 18 ³ / ₈ in		1088807.0-N200 1088807.0-N100 1088807.0-N400 1088807.0-N300
---	--	---	---	--

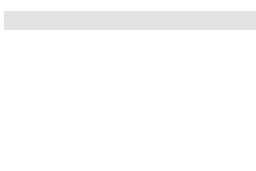
	Tagliere copri lavello Yòza in Corian® FEY 450 UT Corian® cutting board cover for Yòza sink FEY 450 UT	420 x 480 mm 16 ¹ / ₂ X 18 ³ / ₈ in		1088812.0-K100
---	--	---	---	----------------

Cucina monoblocco Agher

Agher monobloc kitchen

Agher interpreta la personalizzazione come espressione di carattere. La combinazione di materiali e colori permette di definire cucine uniche, mentre i piani modulari offrono la libertà di predisporre gli elettrodomestici a piacimento, adattandosi a qualsiasi progetto outdoor senza compromettere funzionalità e praticità.

Agher interprets personalization as an expression of character. The combination of materials and colors allows unique kitchen configurations, while modular countertops offer the freedom to arrange appliances freely, adapting to any outdoor project without compromising functionality or practicality.

Configurazioni

Configurations

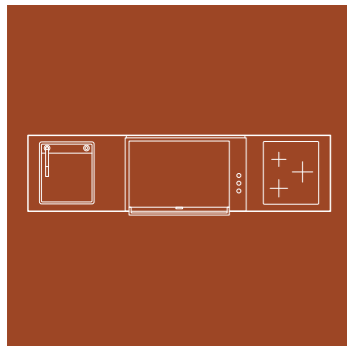

Isola
Island

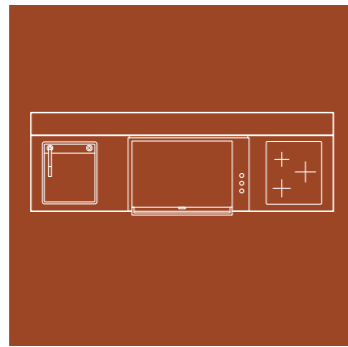

A muro
One-wall kitchen

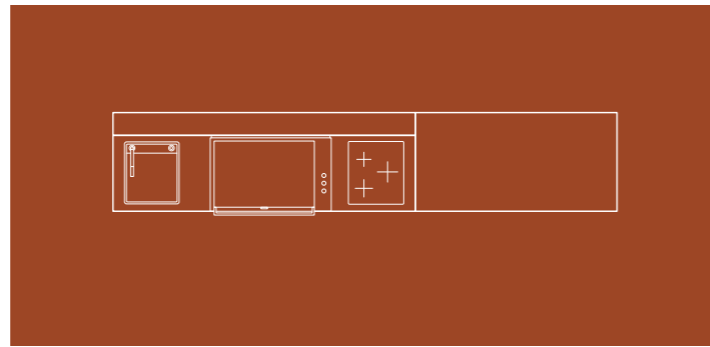

Con tavolo – Forma lineare o ad L
With table – Linear or L-shaped

La cucina Agher unisce compattezza e prestazioni elevate in un design modulare e lineare. Il piano di 2400x600 mm permettono di disporre liberamente gli elettrodomestici e organizzare le postazioni di lavoro secondo le esigenze del progetto outdoor.

The Agher kitchen combines compactness and high performance in a modular, linear design. The 2400 x 600 mm (94 1/2 x 23 5/8 in) worktop allow appliances and workstations to be arranged according to the needs of the outdoor project.

Moduli cucina

Cooking modules

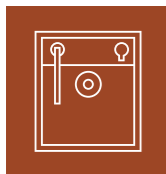

Lavello
Sink

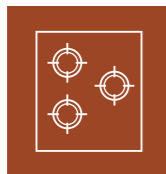

Induzione
Induction

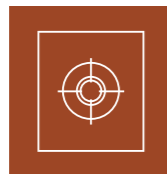

Gas
Gas

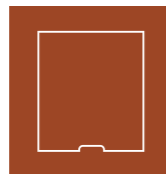

Tagliere
Cutting board

Sistemi di cottura Fògher

Fògher cooking systems



BBQ a gas ad incasso con coperchio forno
Built-in gas BBQ with oven lid



BBQ ad incasso a gas con coperchio basso
Built-in gas BBQ with low lid

Materiali e finiture

Materials and finishes

Agher prevede un numero definito di combinazioni cromatiche, studiate per valorizzare il disegno del prodotto e garantirne un'identità visiva precisa. La personalizzazione è guidata, pensata per assicurare equilibrio estetico e riconoscibilità progettuale.

Agher features a defined set of color combinations, developed to enhance the product's design and ensure a precise and recognizable visual identity. Personalization is guided, ensuring aesthetic balance and design consistency.

Agher Premium amplia il sistema di configurazione, introducendo una maggiore articolazione tra piani e strutture. La possibilità di intervenire separatamente sugli elementi consente un livello superiore di personalizzazione, mantenendo elevati standard di coerenza e qualità progettuale.

Agher Premium expands the configuration system, introducing greater articulation between worktops and structural elements. The ability to configure individual components independently allows for a higher level of customization, while maintaining high standards of coherence and design quality.

Agher

Combinazioni Combinations

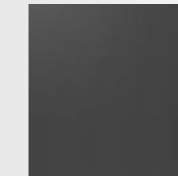

Ossidiana
Obsidian

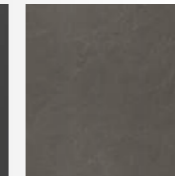

MDI pacific gris
MDI pacific gris



Seta Materica
Material Sink



MDI pacific blanco
MDI pacific white

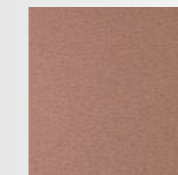

Terra di Siena
Sienna

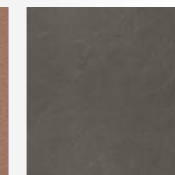

MDI pacific gris
MDI pacific gris



Salvia Antica
Ancient Sage



MDI pacific blanco
MDI pacific white

Agher premium

Base Base

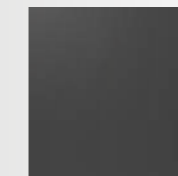

Ossidiana
Obsidian

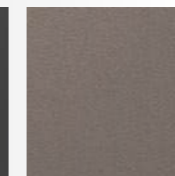

Bronzo vivo
Live bronze



Terra di Siena
Sienna

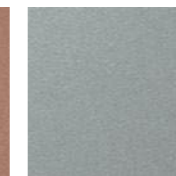

Soffio di Baia
Bay breeze



Salvia Antica
Ancient Sage



Seta Materica
Material Sink

Piano Top

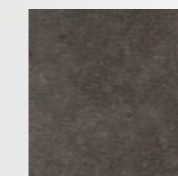

Roccia bruna
Dark rock

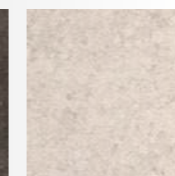





Duna chiara
Light dune





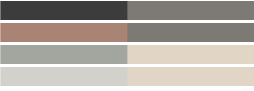

Codici di riferimento Agher

Prodotto Product	Nome prodotto Product name	Misure (LxPxA) mm Measures (LxDxH) in	Finitura Finishing	Codice Code
---------------------	-------------------------------	--	-----------------------	----------------

Moduli base Agher Agher base modules



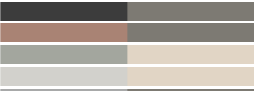

	Modulo cucina Standard Kitchen module Standard	2400 x 600 x 910 mm 94 1/2 x 23 3/8 x 35 7/8 in		1088576.0-M201 1088576.0-M202 1088576.0-M104 1088576.0-M105
	Modulo cucina Neutra (no foro centrale) Kitchen module Work station (without bbq hole)	2400 x 600 x 910 mm 94 1/2 x 23 3/8 x 35 7/8 in		1088577.0-M201 1088577.0-M202 1088577.0-M104 1088577.0-M105
	Modulo cucina J.Bastianich Inox AISI 316 Kitchen module J.Bastianich AISI 316 stainless steel	2400 x 600 x 910 mm 94 1/2 x 23 3/8 x 35 7/8 in		1088822.0-M207

Accessori cucina Agher Agher kitchen accessories







	Snack bar 18 Serving bar 18	2400 x 180 x 910 mm 94 1/2 x 7 1/8 x 35 7/8 in		1088801.0-M201 1088801.0-M202 1088801.0-M104 1088801.0-M105 1088825.0-0007
	Schiena di chiusura per snack bar Back closure panel for serving bar	2400 x 734 mm 94 1/2 x 28 7/8 in		1088802.0-0004 1088802.0-0005 1088802.0-0001 1088802.0-0002 1088802.0-0007 1088802.0-0009 1088802.0-0003
	Snack bar 25 Serving bar 25	2400 x 250 x 250 mm 94 1/2 x 9 7/8 x 9 7/8 in		1088803.0-M104 1088803.0-M105 1088803.0-M201 1088803.0-M202 1088826.0-M207
	Kit zoccolo Kitchen kickboard kit	2370 x 530 x 140 mm 93 3/4 x 20 7/8 x 5 1/2 in		1085460

Agher key codes

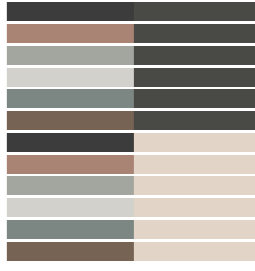

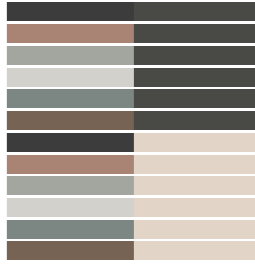

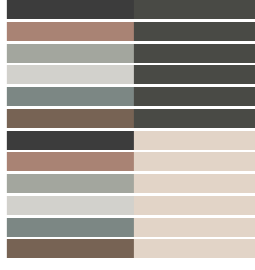

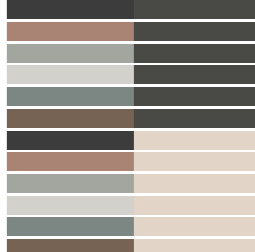
Prodotto Product	Nome prodotto Product name	Misure (LxPxA) mm Measures (LxDxH) in	Finitura Finishing	Codice Code
---------------------	-------------------------------	--	-----------------------	----------------

	Tavolo Agher Agher table	1600 x 780 x 910 mm 63 x 30 3/4 x 35 7/8 in		1088578.0-M201 1088578.0-M202 1088578.0-M104 1088578.0-M105 1088827.0-M207
	Kit 2 sgabelli Agher Agher 2 stool kit	650 x 440 x 960 mm 25 5/8 x 17 3/8 x 37 3/4 in		1088804.0-0004 1088804.0-0005 1088804.0-0001 1088804.0-0002

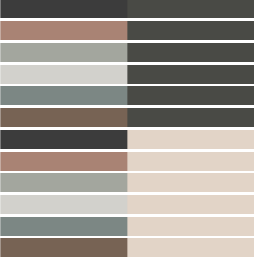

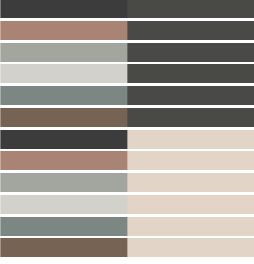
Moduli base AgherPremium Agher Premium base modules

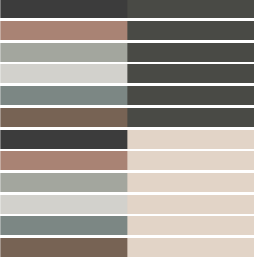
	Modulo cucina Premium Kitchen module Premium	2400 x 600 x 910 mm 94 1/2 x 23 3/8 x 35 7/8 in		1088576.0-N401 1088576.0-N402 1088576.0-N404 1088576.0-N405 1088576.0-N409 1088576.0-N403 1088576.0-N301 1088576.0-N302 1088576.0-N304 1088576.0-N305 1088576.0-N309 1088576.0-N303
	Modulo cucina Premium - foro sx Kitchen module Premium - left cut out	2400 x 600 x 910 mm 94 1/2 x 23 3/8 x 35 7/8 in		1088828.0-N401 1088828.0-N402 1088828.0-N404 1088828.0-N405 1088828.0-N409 1088828.0-N403 1088828.0-N301 1088828.0-N302 1088828.0-N304 1088828.0-N305 1088828.0-N309 1088828.0-N303
	Modulo cucina Premium - foro dx Kitchen module Premium - right cut out	2400 x 600 x 910 mm 94 1/2 x 23 3/8 x 35 7/8 in		1088829.0-N401 1088829.0-N402 1088829.0-N404 1088829.0-N405 1088829.0-N409 1088829.0-N403 1088829.0-N301 1088829.0-N302 1088829.0-N304 1088829.0-N305 1088829.0-N309 1088829.0-N303
	Modulo cucina Premium - solo foro centrale Kitchen module Premium - only central cut out	2400 x 600 x 910 mm 94 1/2 x 23 3/8 x 35 7/8 in		1088820.0-N401 1088820.0-N402 1088820.0-N404 1088820.0-N405 1088820.0-N409 1088820.0-N403 1088820.0-N301 1088820.0-N302 1088820.0-N304 1088820.0-N305 1088820.0-N309 1088820.0-N303

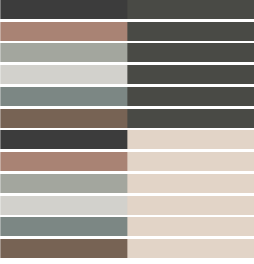

Codici di riferimento Agher

Prodotto Product	Nome prodotto Product name	Misure (LxPxA) mm Measures (LxDxH) in	Finitura Finishing	Codice Code
	Modulo cucina Premium neutra - fori sx/dx Kitchen module Premium neutral - left and right cut out	2400 x 600 x 910 mm 94½ x 23⅝ x 35 ⅞ in		1088577.0-N401 1088577.0-N402 1088577.0-N404 1088577.0-N405 1088577.0-N409 1088577.0-N403 1088577.0-N301 1088577.0-N302 1088577.0-N304 1088577.0-N305 1088577.0-N309 1088577.0-N303
	Modulo cucina Premium neutra - foro sx Kitchen module Premium neutral - left cut out	2400 x 600 x 910 mm 94½ x 23⅝ x 35 ⅞ in		1088830.0-N401 1088830.0-N402 1088830.0-N404 1088830.0-N405 1088830.0-N409 1088830.0-N403 1088830.0-N403 1088830.0-N301 1088830.0-N302 1088830.0-N304 1088830.0-N305 1088830.0-N309 1088830.0-N303
	Modulo cucina Premium neutra - foro dx Kitchen module Premium neutral - right cut out	2400 x 600 x 910 mm 94½ x 23⅝ x 35 ⅞ in		1088831.0-N401 1088831.0-N402 1088831.0-N404 1088831.0-N405 1088831.0-N409 1088831.0-N403 1088831.0-N301 1088831.0-N302 1088831.0-N304 1088831.0-N305 1088831.0-N309 1088831.0-N303
	Modulo cucina Premium neutra - senza fori Kitchen module Premium neutral - without cut out	2400 x 600 x 910 mm 94½ x 23⅝ x 35 ⅞ in		1088832.0-N401 1088832.0-N402 1088832.0-N404 1088832.0-N405 1088832.0-N409 1088832.0-N403 1088832.0-N301 1088832.0-N302 1088832.0-N304 1088832.0-N305 1088832.0-N309 1088832.0-N303

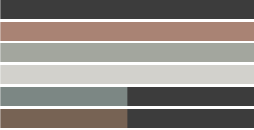



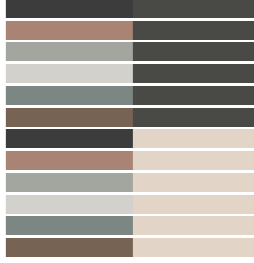





Accessori cucina Agher Premium Agher Premium kitchen accessories

	Snack bar 180 Premium Snack bar 180 Premium	2400 x 180 x 910 mm 94½ x 7⅛ x 35 ⅞ in		1088801.0-N401 1088801.0-N402 1088801.0-N404 1088801.0-N405 1088801.0-N409 1088801.0-N403 1088801.0-N301 1088801.0-N302 1088801.0-N304 1088801.0-N305 1088801.0-N309 1088801.0-N303
	Kit 2 sgabelli Agher Agher 2 stool kit	650 x 440 x 960 mm 25⅝ x 17⅜ x 37¼ in		1088804.0-0004 1088804.0-0005 1088804.0-0001 1088804.0-0002 1088804.0-0009 1088804.0-0003



Agher key codes

Prodotto Product	Nome prodotto Product name	Misure (LxPxA) mm Measures (LxDxH) in	Finitura Finishing	Codice Code
	Snack bar 250 Premium Serving bar 250 Premium	2400 x 250 x 250 mm 94½ x 9⅞ x 9⅞ in		1088803.0-N401 1088803.0-N402 1088803.0-N404 1088803.0-N405 1088803.0-N409 1088803.0-N403 1088803.0-N301 1088803.0-N302 1088803.0-N304 1088803.0-N305 1088803.0-N309 1088803.0-N303
	Tavolo Agher Premium Agher table Premium	1600 x 780 x 910 mm 63 x 30¾ x 35 ⅞ in		1088578.0-N401 1088578.0-N402 1088578.0-N404 1088578.0-N405 1088578.0-N409 1088578.0-N403 1088578.0-N301 1088578.0-N302 1088578.0-N304 1088578.0-N305 1088578.0-N309 1088578.0-N303





Elettrodomestici Agher Agher appliances

	FEL 453 ST Piano cottura induzione Lùxar 3 zone FEL 453 ST Lùxar Induction cooktop 3 zones	450 x 520 mm 17¾ x 20½ in		1084215.1*
	FEF 4514 SE Piano cottura gas Fiuma 1 fuoco dual FEF 4514 SE Fiuma gas cooktop 1 dual burner	450 x 520 mm 17¾ x 20½ in		1084508.1*
	FEF 4532 SE Piano cottura gas Fiuma 3 fuochi FEF 4532 SE Fiuma gas cooktop 3 burners	450 x 520 mm 17¾ x 20½ in		1084501.1*
	FEY 450 NA Lavello Yòza FEY 450 NA Yòza Sink	440 x 510 mm 17⅞ x 20⅞ in		1089742.0
	FEY 450 UT Lavello Yòza FEY 450 UT Yòza Sink	440 x 500 mm 17⅞ x 19⅝ in		1084796.0





Codici di riferimento Agher

Prodotto Product	Nome prodotto Product name	Misure (LxPxA) mm Measures (LxDxH) in	Finitura Finishing	Codice Code
	FEY 950 ST Sistema lavello Yòza FEY 950 ST Yòza Sink System	970 x 530 x 230 mm 38 ³ / ₁₆ x 20 ⁷ / ₈ x 9 in		1084797.0

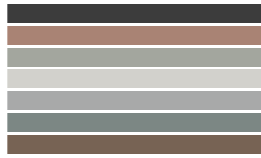

Sistemi di cottura ad incasso FGB FGB built in cooking systems

	Sistema di cottura FGB 750 FGB 750 built-in cooking system	963 x 575 x 217 mm 37 ⁷ / ₈ x 22 ³ / ₄ x 8 ¹ / ₂ in		1085771.1*
	Sistema di cottura FGB 750 FO FGB 750 FO built-in cooking system	963 x 615 x 382 mm 37 ⁷ / ₈ x 24 ¹ / ₄ x 15 in		1085772.1*



Modelli refrigerazione Agher Agher refrigeration models

	Frigo outdoor e kit per incasso Outdoor refrigerator with built-in kit	548 x 553 x 622 mm 21 ⁹ / ₁₆ x 21 ⁹ / ₄ x 24 ¹ / ₂ in		1084601.1-0001
	Cantinetta vini outdoor e kit per incasso Outdoor wine cooler with built-in kit	595 x 504 x 632 mm 23 ³ / ₈ x 19 ¹ / ₈ x 23 ¹ / ₈ in		1088805.1-0001 1088805.1-0002 1088805.1-0004 1088805.1-0005 1088805.1-0007 1088805.1-0009 1088805.1-0003
	Fabbricatore ghiaccio nautico Inox AISI 316 Marine ice maker AISI 316 stainless steel	353 x 405 x 582 mm 13 ⁷ / ₈ x 16 x 22 ⁷ / ₈ in		1084815.1*





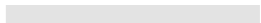

Accessori copri foro Agher Agher cut out cover accessories

	Vaschetta sotto top con copri fori in MDI Under-counter tray with MDI hole cover plate	420 x 480 mm 16 ¹ / ₂ X 18 ³ / ₈ in		1088812.0-M200 1088812.0-M100
--	--	---	--	--





Agher key codes

Prodotto Product	Nome prodotto Product name	Misure (LxPxA) mm Measures (LxDxH) in	Finitura Finishing	Codice Code
	Vaschetta sotto top con copri fori in MDI - Premium Under-counter tray with MDI hole cover plate - Premium	420 x 480 mm 16 ¹ / ₂ X 18 ³ / ₈ in		1088812.0-N400 1088812.0-N300
	Vaschetta sotto top con tagliere in Corian® Under-counter tray with Corian® cutting board	420 x 480 mm 16 ¹ / ₂ X 18 ³ / ₈ in		1088812.0-K100











Accessori copri foro Agher Agher cut out cover accessories

	Vaschetta sotto top con copri fori in ceramica super sinterizzata Premium Under-counter tray with ultra-sintered ceramic hole cover plate Premium	420 x 480 mm 16 ¹ / ₂ X 18 ³ / ₈ in		1088807.0-M200 1088807.0-M100
	Tagliere copri lavello Yòza in Corian® FEY 450 UT Corian® cutting board cover for Yòza sink FEY 450 UT	420 x 480 mm 16 ¹ / ₂ X 18 ³ / ₈ in		1088812.0-K100
	Copri lavello in ceramica super sinterizzata Yòza FEY 450 UT Premium Ultra-sintered ceramic Yòza FEY 450 UT sink cover Premium	420 x 480 mm 16 ¹ / ₂ X 18 ³ / ₈ in		1088807.0-N400 1088807.0-N300

Accessori Agher Agher accessories

	Cassettiera Agher Cassetto + cassettone Agher Drawer Unit Drawer + Deep Drawer	595x553x622mm 23 ³ / ₈ x 21 ⁹ / ₄ x 24 ¹ / ₂ in		1088833.0-0001
	Sistema smaltimento rifiuti Waste disposal system	443 x 304 x 405 mm 17 ¹ / ₂ x 12 x 16 in		1083381.0

Codici di riferimento Agher

Prodotto Product	Nome prodotto Product name	Misure (LxPxA) mm Measures (LxDxH) in	Finitura Finishing	Codice Code
	Portaspezie Agher 700 Spice rack 700	700 x 180 mm 27½ x 7¼ in		1088797.0-0001
	Paraschizzi da muro Upstand panel	2400 x 700 mm 94½ x 27½ in	 	1088809.0-M200 1088809.0-M100
	Battistraccio Splashback panel	2400 x 80 mm 94½ x 3¼ in	 	1088810.0-M200 1088810.0-M100
	Kit ruote* Wheel Kit*			1082303.0

Coperture Agher Agher cover

	Copertura cucina isola Agher Agher island kitchen cover	2400 x 600 x 1310 mm 94½ x 23⅝ x 51½ in		1082439.0
	Copertura cucina con Snack bar Agher Agher kitchen cover with serving bar	2400 x 780 x 1310 mm 94½ x 30¾ x 51½ in		1082440.0
	Copertura tavolo cucina Agher Agher Kitchen table cover	1600 x 780 mm 63 x 30¾ in		1082441.0
	Copertura magnetica Barbecue FGB 750 FO Magnetic cover for FGB 750 FO barbecue	1600 x 780 mm 63 x 30¾ x in		1083940.0

Agher key codes



Cucina modulare Lares

Lares modular kitchen

La modularità di Lares mette l'equilibrio al centro: superfici e basi si combinano per creare soluzioni armoniche, adattabili a spazi di diverse dimensioni e stili. Ogni configurazione mantiene coerenza estetica e versatilità operativa.

Lares modularity places balance at the core: surfaces and bases combine to create harmonious solutions, adaptable to spaces of varying sizes and styles. Each configuration ensures aesthetic consistency and operational versatility.

Configurazioni

Configurations

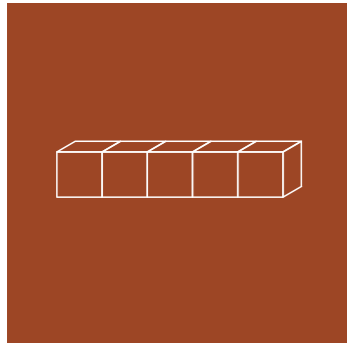

Lineare
Linear

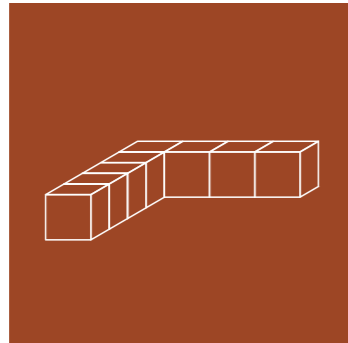

Ad angolo
L-Shaped

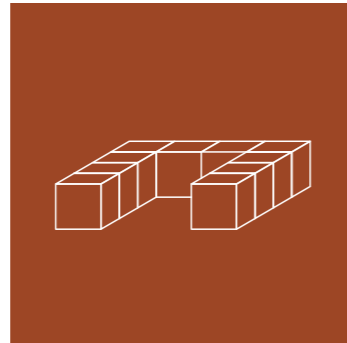

A ferro di cavallo
C-Shaped

Creare la vostra cucina da esterno Lares è immediato: i moduli da 85, 385, 700, 700+300 e 1000 mm, uniti ai sistemi di cottura Fògher, consentono combinazioni personalizzate per adattarsi a qualsiasi spazio.

Creating your own Lares outdoor kitchen is straightforward: the 85, 385, 700, 700+300, and 1000 mm modules, combined with Fògher cooking systems, enable customized configurations to suit any space.

Moduli cucina

Cooking modules



Neutro
Worktop



Cottura
Cooking



Supporto
Support



Lavello
Sink



Frigido
Fridge



Kit giunzione
Junction kit



Carenature
e accessori
Doors and
accessories

Sistemi di cottura Fògher

Fògher cooking systems



BBQ a gas
Gas BBQ



BBQ ad incasso
a gas
Built-in gas
BBQ



Caminetto grill
Outdoor
fireplace

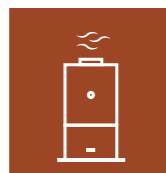

Smoker
Smoker

Materiali e finiture

Materials and finishes

Lares offre un sistema di personalizzazione strutturato, basato sulla combinazione controllata di superfici e basamenti. Le diverse configurazioni consentono di modulare l'aspetto della cucina mantenendo coerenza formale e funzionale in ogni contesto di utilizzo.

Lares offers a structured customization system based on the controlled combination of surfaces and base units. The available configurations allow the appearance of the kitchen to be modulated while maintaining formal and functional coherence across different contexts of use.

Lares

Combinazioni Combinations

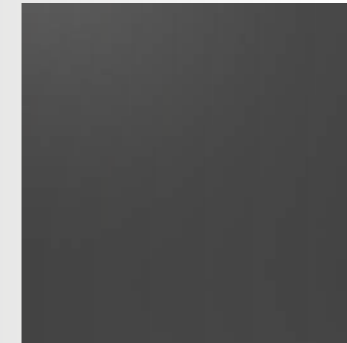

Ossidiana
Obsidian

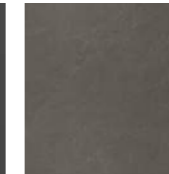

MDI Pacific Gris
MDI Pacific Gris



MDI Pacific
Blanco
MDI Pacific
White



Acciaio inox
316 Reditage
Stainless steel
316 Reditage

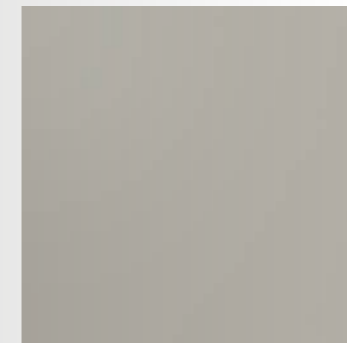

Seta Materica
Material Sink



MDI Pacific
Blanco
MDI Pacific
White

Moduli Lares

Lares modules

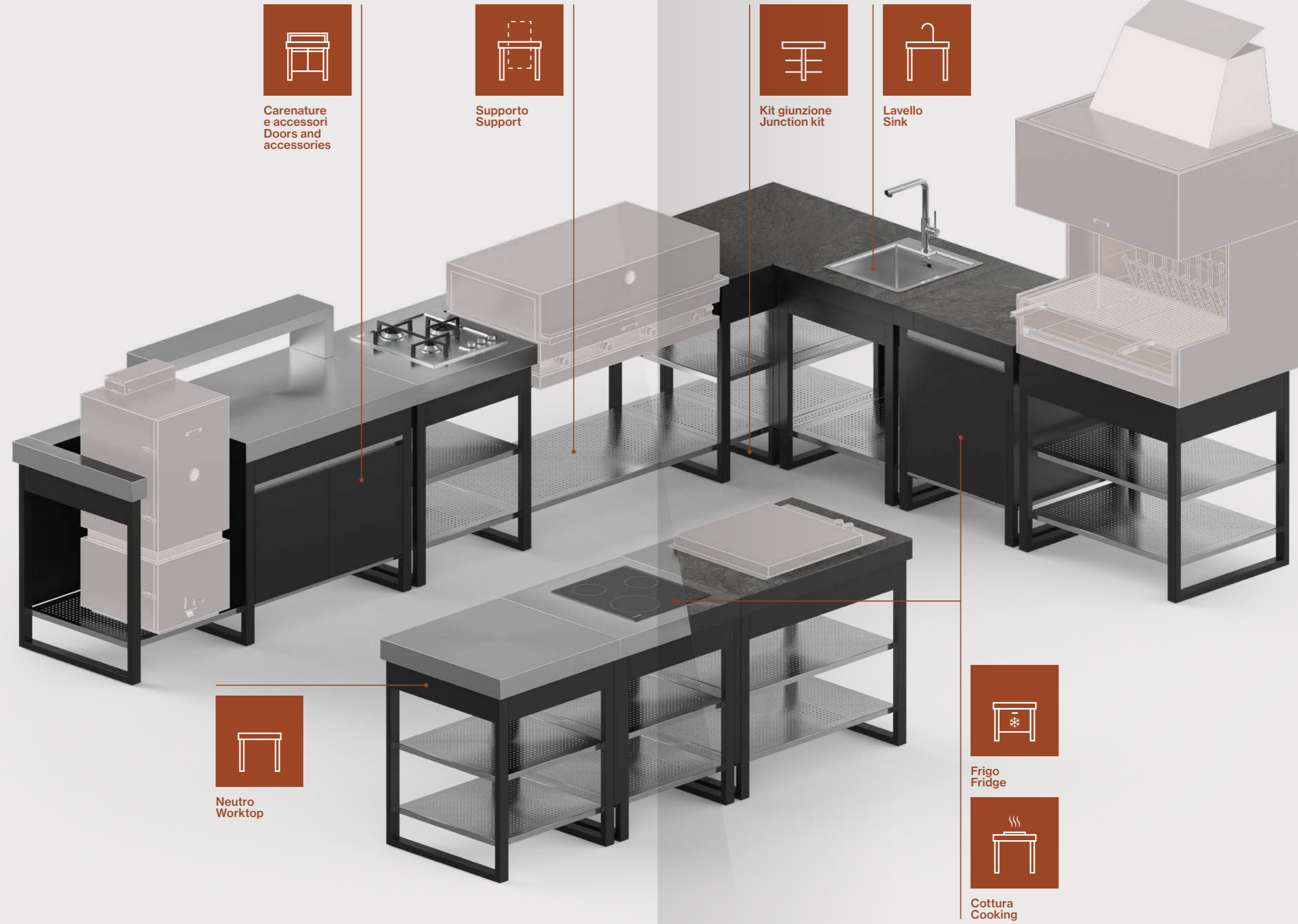

Carenature e accessori
Doors and accessories



Supporto
Support



Kit giunzione
Junction kit



Lavello
Sink



Neutro
Worktop

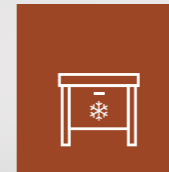

Frigo
Fridge



Cottura
Cooking

Moduli Lares

Lares modules



BBQ a gas
Gas BBQ

Modelli
compatibili:
Compatible
models:

- FGA 500
- FGA 500 FO
- FGA 750
- FGA 750 FO
- FGA 1000
- FGA 1000 FO

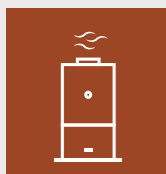
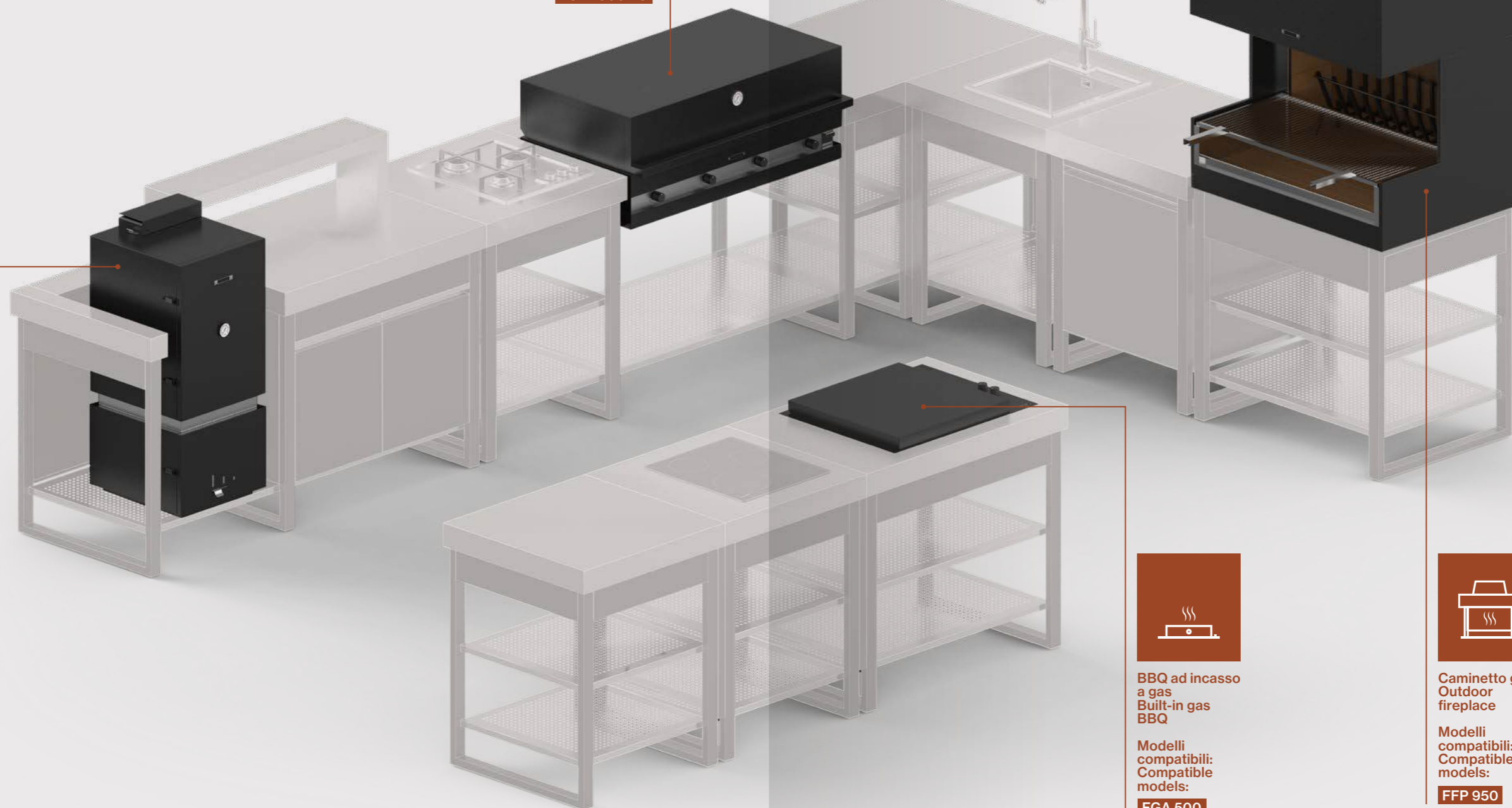

Smoker
Smoker

Modelli
compatibili:
Compatible
models:

- WS 450
- RF 450

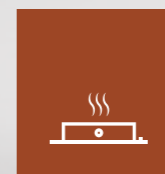

BBQ ad incasso
a gas
Built-in gas
BBQ

Modelli
compatibili:
Compatible
models:

- FGA 500
- FGA 500 FO

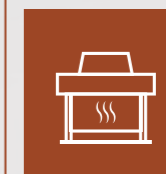

Caminetto grill
Outdoor
fireplace











Modelli
compatibili:
Compatible
models:

- FFP 950

Codici di riferimento Lares

Prodotto Product	Nome prodotto Product name	Misure (LxPxA) mm Measures (LxDxH) in	Finitura Finishing	Codice Code
---------------------	-------------------------------	--	-----------------------	----------------

Moduli neutri Modular cabinets

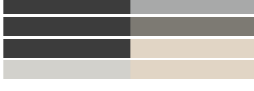
	Modulo neutro 85 Cabinet 85	85 x 700 x 910 mm 3 ³ / ₈ x 27 ¹ / ₂ x 35 ⁷ / ₈ in		1088688.0-E201 1088688.0-M201 1088688.0-M101 1088688.0-M105
	Modulo neutro 385 Cabinet 385	385 x 700 x 910 mm 15 ¹ / ₈ x 27 ¹ / ₂ x 35 ⁷ / ₈ in		1088689.0-E201 1088689.0-M201 1088689.0-M101 1088689.0-M105
	Modulo neutro 700 Cabinet 700	700 x 700 x 910 mm 27 ¹ / ₂ x 27 ¹ / ₂ x 35 ⁷ / ₈ in		1088691.0-E201 1088691.0-M201 1088691.0-M101 1088691.0-M105
	Modulo neutro 700+300 dx Cabinet 700+300 right	1000 x 700 x 910 mm 39 ³ / ₈ x 27 ¹ / ₂ x 35 ⁷ / ₈ in		1088728.0-E201 1088728.0-M201 1088728.0-M101 1088728.0-M105
	Modulo neutro 700+300 sx Cabinet 700+300 left	1000 x 700 x 910 mm 39 ³ / ₈ x 27 ¹ / ₂ x 35 ⁷ / ₈ in		1088724.0-E201 1088724.0-M201 1088724.0-M101 1088724.0-M105
	Modulo neutro 1000 Cabinet 1000	1000 x 700 x 910 mm 39 ³ / ₈ x 27 ¹ / ₂ x 35 ⁷ / ₈ in		1088700.0-E201 1088700.0-M201 1088700.0-M101 1088700.0-M105

Moduli neutri carenati Modular cabinets - door

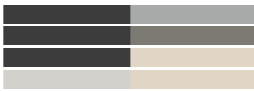
	Modulo 385 carenato Cabinet 85 - full door	385 x 700 x 910 mm 15 ¹ / ₈ x 27 ¹ / ₂ x 35 ⁷ / ₈ in		1088690.0-E201 1088690.0-M201 1088690.0-M101 1088690.0-M105
--	--	--	--	--

Lares key codes





Prodotto Product	Nome prodotto Product name	Misure (LxPxA) mm Measures (LxDxH) in	Finitura Finishing	Codice Code
---------------------	-------------------------------	--	-----------------------	----------------

	Modulo 700 carenato Cabinet 700 - full door	700 x 700 x 910 mm 27 ¹ / ₂ x 27 ¹ / ₂ x 35 ⁷ / ₈ in		1088692.0-E201 1088692.0-M201 1088692.0-M101 1088692.0-M105
	Modulo 700+300 sx carena sx Cabinet 700+300 left - left small door	1000 x 700 x 910 mm 39 ³ / ₈ x 27 ¹ / ₂ x 35 ⁷ / ₈ in		1088725.0-E201 1088725.0-M201 1088725.0-M101 1088725.0-M105
	Modulo 700+300 sx carena dx Cabinet 700+300 left - right large door	1000 x 700 x 910 mm 39 ³ / ₈ x 27 ¹ / ₂ x 35 ⁷ / ₈ in		1088731.0-E201 1088731.0-M201 1088731.0-M101 1088731.0-M105
	Modulo 700+300 sx carenato Cabinet 700+300 left - full door	1000 x 700 x 910 mm 39 ³ / ₈ x 27 ¹ / ₂ x 35 ⁷ / ₈ in		1088731.0-E201 1088731.0-M201 1088731.0-M101 1088731.0-M105
	Modulo 700+300 dx carena dx Cabinet 700+300 right - right small door	1000 x 700 x 910 mm 39 ³ / ₈ x 27 ¹ / ₂ x 35 ⁷ / ₈ in		1088726.0-E201 1088726.0-M201 1088726.0-M101 1088726.0-M105
	Modulo 700+300 dx carena sx Cabinet 700+300 right - left large door	1000 x 700 x 910 mm 39 ³ / ₈ x 27 ¹ / ₂ x 35 ⁷ / ₈ in		1088725.0-E201 1088725.0-M201 1088725.0-M101 1088725.0-M105
	Modulo 700+300 dx carenato Cabinet 700+300 right - full door	1000 x 700 x 910 mm 39 ³ / ₈ x 27 ¹ / ₂ x 35 ⁷ / ₈ in		1088727.0-E201 1088727.0-M201 1088727.0-M101 1088727.0-M105
	Modulo 1000 carenato Cabinet 1000 - full door	1000 x 700 x 910 mm 39 ³ / ₈ x 27 ¹ / ₂ x 35 ⁷ / ₈ in		1088701.0-E201 1088701.0-M201 1088701.0-M101 1088701.0-M105





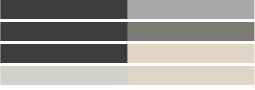

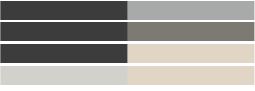

Codici di riferimento Lares

Prodotto Product	Nome prodotto Product name	Misure (LxPxA) mm Measures (LxDxH) in	Finitura Finishing	Codice Code
---------------------	-------------------------------	--	-----------------------	----------------

Moduli foro a sinistra Modular cabinets - left cut out

	Modulo 700 foro sx Cabinet 700 - left cut out	700 x 700 x 910 mm 27½ x 27½ x 35 ⅞ in		1088693.0-E201 1088693.0-M201 1088693.0-M101 1088693.0-M105
	Modulo 700+300 foro sx Cabinet 700+300 - left cut out	1000 x 700 x 910 mm 39⅝ x 27½ x 35 ⅞ in		1088732.0-E201 1088732.0-M201 1088732.0-M101 1088732.0-M105
	Modulo 1000 foro sx Cabinet 1000 - left cut out	1000 x 700 x 910 mm 39⅝ x 27½ x 35 ⅞ in		1088702.0-E201 1088702.0-M201 1088702.0-M101 1088702.0-M105



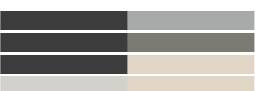

Moduli foro a sinistra carenati Modular cabinets - left cut out - door

	Modulo 700 foro sx carenato Cabinet 700 - left cut out - full door	700 x 700 x 910 mm 27½ x 27½ x 35 ⅞ in		1088694.0-E201 1088694.0-M201 1088694.0-M101 1088694.0-M105
	Modulo 700+300 foro sx carena sx Cabinet 700+300 - left cut out - small right door	1000 x 700 x 910 mm 39⅝ x 27½ x 35 ⅞ in		1088734.0-E201 1088734.0-M201 1088734.0-M101 1088734.0-M105
	Modulo 700+300 foro sx carena dx Cabinet 700+300 - left cut out - large left door	1000 x 700 x 910 mm 39⅝ x 27½ x 35 ⅞ in		1088733.0-E201 1088733.0-M201 1088733.0-M101 1088733.0-M105
	Modulo 700+300 foro sx carenato Cabinet 700+300 - left cut out - full door	1000 x 700 x 910 mm 39⅝ x 27½ x 35 ⅞ in		1088735.0-E201 1088735.0-M201 1088735.0-M101 1088735.0-M105
	Modulo 1000 foro sx carenato Cabinet 1000 - left cut out - full door	1000 x 700 x 910 mm 39⅝ x 27½ x 35 ⅞ in		1088703.0-E201 1088703.0-M201 1088703.0-M101 1088703.0-M105





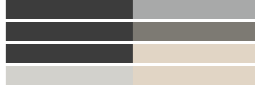

Lares key codes

Prodotto Product	Nome prodotto Product name	Misure (LxPxA) mm Measures (LxDxH) in	Finitura Finishing	Codice Code
---------------------	-------------------------------	--	-----------------------	----------------

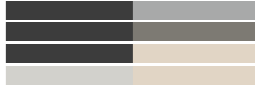
Moduli foro a destra Modular cabinets - right cut out

	Modulo 700 foro dx Cabinet 700 - right cut out	700 x 700 x 910 mm 27½ x 27½ x 35 ⅞ in		1088695.0-E201 1088695.0-M201 1088695.0-M101 1088695.0-M105
	Modulo 700+300 foro dx Cabinet 700+300 - right cut out	1000 x 700 x 910 mm 39⅝ x 27½ x 35 ⅞ in		1088736.0-E201 1088736.0-M201 1088736.0-M101 1088736.0-M105
	Modulo 1000 foro dx Cabinet 1000 - right cut out	1000 x 700 x 910 mm 39⅝ x 27½ x 35 ⅞ in		1088704.0-E201 1088704.0-M201 1088704.0-M101 1088704.0-M105









Moduli foro a destra carenati Modular cabinets - left cut out - door

	Modulo 700 foro dx carenato Cabinet 700 - right cut out - full door	700 x 700 x 910 mm 27½ x 27½ x 35 ⅞ in		1088696.0-E201 1088696.0-M201 1088696.0-M101 1088696.0-M105
	Modulo 700+300 foro dx carena sx Cabinet 700+300 - right cut out - small right door	1000 x 700 x 910 mm 39⅝ x 27½ x 35 ⅞ in		1088737.0-E201 1088737.0-M201 1088737.0-M101 1088737.0-M105
	Modulo 700+300 foro dx carena dx Cabinet 700+300 - right cut out - large left door	1000 x 700 x 910 mm 39⅝ x 27½ x 35 ⅞ in		1088738.0-E201 1088738.0-M201 1088738.0-M101 1088738.0-M105
	Modulo 700+300 foro dx carenato Cabinet 700+300 - right cut out - full door	1000 x 700 x 910 mm 39⅝ x 27½ x 35 ⅞ in		1088739.0-E201 1088739.0-M201 1088739.0-M101 1088739.0-M105
	Modulo 1000 foro dx carenato Cabinet 1000 - right cut out - full door	1000 x 700 x 910 mm 39⅝ x 27½ x 35 ⅞ in		1088705.0-E201 1088705.0-M201 1088705.0-M101 1088705.0-M105

Codici di riferimento Lares

Prodotto Product	Nome prodotto Product name	Misure (LxPxA) mm Measures (LxDxH) in	Finitura Finishing	Codice Code
---------------------	-------------------------------	--	-----------------------	----------------

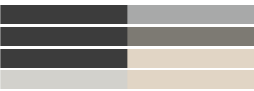
Moduli carrello Wheeled cabinets

	Modulo carrello 1000 ruote dx Cabinet 1000 - right wheels	1000 x 700 x 910 mm 39 3/8 x 27 1/2 x 35 7/8 in		1088714.0-E201 1088714.0-M201 1088714.0-M101 1088714.0-M105
	Modulo carrello 1000 ruote dx foro sx Cabinet 1000 - right wheels - left cut out	1000 x 700 x 910 mm 39 3/8 x 27 1/2 x 35 7/8 in		1088720.0-E201 1088720.0-M201 1088720.0-M101 1088720.0-M105
	Modulo carrello 1000 ruote dx foro dx Cabinet 1000 - right wheels - right cut out	1000 x 700 x 910 mm 39 3/8 x 27 1/2 x 35 7/8 in		1088722.0-E201 1088722.0-M201 1088722.0-M101 1088722.0-M105
	Modulo carrello 1000 ruote sx Cabinet 1000 - left wheels	1000 x 700 x 910 mm 39 3/8 x 27 1/2 x 35 7/8 in		1088712.0-E201 1088712.0-M201 1088712.0-M101 1088712.0-M105
	Modulo carrello 1000 ruote sx foro sx Cabinet 1000 - left wheels - left cut out	1000 x 700 x 910 mm 39 3/8 x 27 1/2 x 35 7/8 in		1088716.0-E201 1088716.0-M201 1088716.0-M101 1088716.0-M105
	Modulo carrello 1000 ruote sx foro dx Cabinet 1000 - left wheels - right cut out	700 x 700 x 910 mm 27 1/2 x 27 1/2 x 35 7/8 in		1088718.0-E201 1088718.0-M201 1088718.0-M101 1088718.0-M105

















Lares key codes

Prodotto Product	Nome prodotto Product name	Misure (LxPxA) mm Measures (LxDxH) in	Finitura Finishing	Codice Code
---------------------	-------------------------------	--	-----------------------	----------------

Moduli carrello Wheeled cabinets - Door

	Modulo carrello 1000 ruote dx carenato Cabinet 1000 - right wheels - full door	1000 x 700 x 910 mm 39 3/8 x 27 1/2 x 35 7/8 in		1088715.0-E201 1088715.0-M201 1088715.0-M101 1088715.0-M105
	Modulo carrello 1000 ruote dx foro sx carenato Cabinet 1000 - right wheels - left cut out - full door	1000 x 700 x 910 mm 39 3/8 x 27 1/2 x 35 7/8 in		1088721.0-E201 1088721.0-M201 1088721.0-M101 1088721.0-M105
	Modulo carrello 1000 ruote dx foro dx carenato Cabinet 1000 - right wheels - right cut out - full door	1000 x 700 x 910 mm 39 3/8 x 27 1/2 x 35 7/8 in		1088723.0-E201 1088723.0-M201 1088723.0-M101 1088723.0-M105
	Modulo carrello 1000 ruote sx carenato Cabinet 1000 - left wheels - full door	1000 x 700 x 910 mm 39 3/8 x 27 1/2 x 35 7/8 in		1088713.0-E201 1088713.0-M201 1088713.0-M101 1088713.0-M105
	Modulo carrello 1000 ruote sx foro sx carenato Cabinet 1000 - left wheels - left cut out - full door	1000 x 700 x 910 mm 39 3/8 x 27 1/2 x 35 7/8 in		1088717.0-E201 1088717.0-M201 1088717.0-M101 1088717.0-M105
	Modulo carrello 1000 ruote sx foro dx carenato Cabinet 1000 - left wheels - right cut out - full door	1000 x 700 x 910 mm 39 3/8 x 27 1/2 x 35 7/8 in		1088719.0-E201 1088719.0-M201 1088719.0-M101 1088719.0-M105

Codici di riferimento Lares



Prodotto Product	Nome prodotto Product name	Misure (LxPxA) mm Measures (LxDxH) in	Finitura Finishing	Codice Code
	Modulo supporto BBQ FGB 500 foro sx Barbecue support module FGB 500 left cut out	1000 x 700 x 910 mm 39 3/8 x 27 1/2 x 35 7/8 in		1088748.0-E201 1088748.0-M201 1088748.0-M101 1088748.0-M105
	Modulo supporto BBQ FGB 500 foro dx Barbecue support module FGB 500 right cut out	1000 x 700 x 910 mm 39 3/8 x 27 1/2 x 35 7/8 in		1088750.0-E201 1088750.0-M201 1088750.0-M101 1088750.0-M105
	Modulo carrello SX BBQ FGB 500 foro sx Barbecue support module FGB 500 - left cut out - left wheels	1000 x 700 x 910 mm 39 3/8 x 27 1/2 x 35 7/8 in		1088752.0-E201 1088752.0-M201 1088752.0-M101 1088752.0-M105
	Modulo carrello SX BBQ FGB 500 foro dx Barbecue support module FGB 500 - right cut out - left wheels	1000 x 700 x 910 mm 39 3/8 x 27 1/2 x 35 7/8 in		1088754.0-E201 1088754.0-M201 1088754.0-M101 1088754.0-M105
	Modulo carrello DX BBQ FGB 500 foro sx Barbecue support module FGB 500 - left cut out - right wheels	1000 x 700 x 910 mm 39 3/8 x 27 1/2 x 35 7/8 in		1088756.0-E201 1088756.0-M201 1088756.0-M101 1088756.0-M105
	Modulo carrello DX BBQ FGB 500 foro dx Barbecue support module FGB 500 - right cut out - right wheels	1000 x 700 x 910 mm 39 3/8 x 27 1/2 x 35 7/8 in		1088758.0-E201 1088758.0-M201 1088758.0-M101 1088758.0-M105
	Modulo supporto smoker 450 450 Smoker support module	580 x 700 mm 22 7/8 x 27 1/2 in		1088763.0-E201 1088763.0-M201 1088763.0-M101 1088763.0-M105
	Modulo supporto Caminetto FFP 950 Fireplace support module	950 x 709 mm 37 3/8 x 27 7/8 in		1088764.0-E201

Lares key codes

Prodotto Product	Nome prodotto Product name	Misure (LxPxA) mm Measures (LxDxH) in	Finitura Finishing	Codice Code
	Kit carenatura supporto BBQ FGA 500 Doors kit for bbq support FGA 500	-		1088767.0-E201 1088767.0-E205
	Kit carenatura supporto BBQ FGA 750 Doors kit for bbq support FGA 750	-		1088768.0-E201 1088768.0-E205
	Kit carenatura supporto BBQ FGA 1000 Doors kit for bbq support FGA 1000	-		1088760.0-E201 1088760.0-E205
	Modulo supporto BBQ FGB 500 foro sx carenato Barbecue support FGB 500 - left cut out - full door	1000 x 700 x 910 mm 39 3/8 x 27 1/2 x 35 7/8 in		1088749.0-E201 1088749.0-M201 1088749.0-M101 1088749.0-M105
	Modulo supporto BBQ FGB 500 foro dx carenato Barbecue support FGB 500 - right cut out - full door	1000 x 700 x 910 mm 39 3/8 x 27 1/2 x 35 7/8 in		1088751.0-E201 1088751.0-M201 1088751.0-M101 1088751.0-M105
	Modulo carrello SX BBQ FGB 500 foro sx carenato Barbecue support FGB 500 - left cut out - left wheels - full door	1000 x 700 x 910 mm 39 3/8 x 27 1/2 x 35 7/8 in		1088752.0-E201 1088752.0-M201 1088752.0-M101 1088752.0-M105
	Modulo carrello SX BBQ FGB 500 foro dx carenato Barbecue support FGB 500 - right cut out - left wheels - full door	1000 x 700 x 910 mm 39 3/8 x 27 1/2 x 35 7/8 in		1088754.0-E201 1088754.0-M201 1088754.0-M101 1088754.0-M105
	Modulo carrello DX BBQ FGB 500 foro sx carenato Barbecue support FGB 500 - left cut out - right wheels - full door	1000 x 700 x 910 mm 39 3/8 x 27 1/2 x 35 7/8 in		1088756.0-E201 1088756.0-M201 1088756.0-M101 1088756.0-M105



Codici di riferimento Lares

Prodotto Product	Nome prodotto Product name	Misure (LxPxA) mm Measures (LxDxH) in	Finitura Finishing	Codice Code
	Modulo carrello DX BBQ FGB 500 foro dx carenato Barbecue support FGB 500 right cut out - right wheels - full door	1000 x 700 x 910 mm 39 ³ / ₈ x 27 ¹ / ₂ x 35 ⁷ / ₈ in		1088758.0-E201 1088758.0-M201 1088758.0-M101 1088758.0-M105



	Modulo supporto caminetto carenato FFP 950 Fireplace support module full door	580 x 700 mm 22 ⁷ / ₈ x 27 ¹ / ₂ in		1088764.0-E201
--	--	---	--	-----------------------



Kit giunzione Junction kit

	Kit giunzione moduli Junction kit	-		1088765.0-E201 1088765.0-E205
--	---	---	--	---



	Kit giunzione moduli ad angolo	-		1088766.0-E201 1088766.0-E205
--	---------------------------------------	---	--	---

Tavolo e sgabelli Wheeled cabinets - Door



	Tavolo Lares Lares table	1600 x 780 x 910 mm 63 x 30 ³ / ₄ x 35 ³ / ₄ in		1088578.0-M201 1088578.0-M105
--	------------------------------------	---	--	---

	Kit 2 sgabelli tavolo Lares Lares table 2 stool kit	650 x 440 x 960 mm 25 ¹ / ₂ x 17 ³ / ₈ x 37 ³ / ₄ in		1088804.0-0004 1088804.0-0002
--	---	--	--	---

Snack bar Snack bar

	Snack bar 1700 Snack bar 1700	1700 x 270 x 1150 mm 66 ⁷ / ₈ x 10 ³ / ₈ x 45 ¹ / ₄ in		1088778.0-0001
--	---	--	--	-----------------------

Lares key codes

Prodotto Product	Nome prodotto Product name	Misure (LxPxA) mm Measures (LxDxH) in	Finitura Finishing	Codice Code
	Snack bar 2000 Snack bar 2000	2000 x 270 x 1150 mm 78 ³ / ₄ x 10 ³ / ₈ x 45 ¹ / ₄ in		1088779.0-0001



	Snack bar 2230 Snack bar 2230	2230 x 270 x 1150 mm 87 ⁷ / ₈ x 10 ³ / ₈ x 45 ¹ / ₄ in		1088780.0-0001
---	---	--	---	-----------------------



	Snack bar 2380 Snack bar 2380	2380 x 270 x 1150 mm 111 ¹ / ₈ x 10 ⁵ / ₈ x 45 ¹ / ₄ in		1088781.0-0001
---	---	---	---	-----------------------



Sgabelli Stools

	Kit 2 sgabelli Snack bar Snack bar 2 stool kit	650 x 440 x 1070 mm 25 ¹ / ₂ x 17 ³ / ₈ x 42 ¹ / ₈ in		1088782.0-0001
---	--	---	---	-----------------------

Appenderia Frame

	Appenderia 2 mt Frame 2 mt	2035 x 660 x 2000 mm 80 ¹ / ₈ x 26 x 78 ³ / ₄ in		1088774.0-0001 1088774.0-0005
---	--------------------------------------	--	---	---

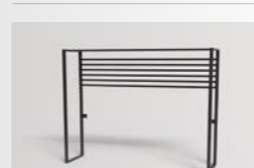





	Appenderia 2,3 mt Frame 2,3 mt	2350 x 660 x 2000 mm 92 ¹ / ₂ x 26 x 78 ³ / ₄ in		1088775.0-0001 1088775.0-0005
---	--	--	---	---

	Appenderia 2,6 mt Frame 2,6 mt	2600 x 660 x 2000 mm 102 ³ / ₈ x 26 x 78 ³ / ₄ in		1088776.0-0001 1088776.0-0005
---	--	---	---	---







Codici di riferimento Lares

Prodotto Product	Nome prodotto Product name	Misure (LxPxA) mm Measures (LxDxH) in	Finitura Finishing	Codice Code
	Appenderia 2,9 mt Frame 2,9 mt	2950 x 660 x 2000 mm 116 ¹ / ₈ x 26 x 78 ³ / ₄ in		1088777.0-0001 1088777.0-0005

Modelli refrigerazione Refrigeration models

	Frigo outdoor e kit per incasso Fully Built-In Refrigerator	548 x 553 x 622 mm 21 ⁹ / ₁₆ x 21 ⁹ / ₄ x 24 ¹ / ₂ in		1088771.1-E201 1088771.1-E205
	Cantinetta vini outdoor e kit per incasso Outdoor wine cooler with built-in kit	595 x 504 x 632 mm 23 ⁷ / ₈ x 19 ⁷ / ₈ x 23 ⁷ / ₈ in		1088773.1-E201 1088773.1-E205
	Fabbricatore ghiaccio nautico Inox AISI 316 Marine ice maker AISI 316 stainless steel	353 x 405 x 582 mm 13 ⁷ / ₈ x 16 x 22 ⁷ / ₈ in		1084815.1*













Elettrodomestici Appliances

	FEL 453 ST Piano cottura induzione Lùxar 3 zone FEL 453 ST Lùxar Induction cooktop 3 zones	450 x 520 mm 17 ³ / ₄ x 20 ¹ / ₂ in		1084215.1*
	FEF 4514 SE Piano cottura gas Fiamo 1 fuoco dual FEF 4514 SE Fiamo gas cooktop 1 dual burner	450 x 520 mm 17 ³ / ₄ x 20 ¹ / ₂ in		1084508.1*
	FEF 4532 SE Piano cottura gas Fiamo 3 fuochi FEF 4532 SE Fiamo gas cooktop 3 burners	450 x 520 mm 17 ³ / ₄ x 20 ¹ / ₂ in		1084501.1*

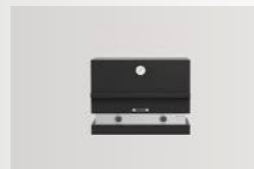
Lares key codes

Prodotto Product	Nome prodotto Product name	Misure (LxPxA) mm Measures (LxDxH) in	Finitura Finishing	Codice Code
	FEY 450 NA Lavello Yòza FEY 450 NA Yòza Sink	440 x 510 mm 17 ³ / ₈ x 20 ¹ / ₈ in		1089742.0
	FEY 450 ST Lavello Yòza FEY 450 UT Yòza Sink	440 x 500 mm 17 ³ / ₈ x 19 ³ / ₈ in		1084796.0



Sistemi di cottura FGA FGA cooking systems



	Sistema di cottura FGA 500 FGA 500 cooking system	550 x 590 x 259 mm 21 ⁵ / ₈ x 23 ¹ / ₄ x 10 ¹ / ₄ in		1085764.1*
	Sistema di cottura FGA 750 FGA 750 cooking system	800 x 590 x 259 mm 31 ¹ / ₂ x 23 ¹ / ₄ x 10 ¹ / ₄ in		1085765.1*
	Sistema di cottura FGA 1000 FGA 1000 cooking system	1051 x 590 x 259 mm 17 ³ / ₄ x 20 ¹ / ₂ x 10 ¹ / ₄ in		1085768.1*
	Sistema di cottura FGA 500 FO FGA 500 FO cooking system	550 x 520 x 424 mm 21 ⁵ / ₈ x 20 ¹ / ₂ x 16 ³ / ₄ in		1085763.1*
	Sistema di cottura FGA 750 FO FGA 750 FO cooking system	800 x 520 x 424 mm 31 ¹ / ₂ x 20 ¹ / ₂ x 16 ³ / ₄ in		1085765.1*
	Sistema di cottura FGA 1000 FO FGA 1000 FO cooking system	1051 x 520 x 424 mm 41 ⁵ / ₈ x 20 ¹ / ₂ x 16 ³ / ₄ in		1085767.1*

Codici di riferimento Lares

Prodotto Product	Nome prodotto Product name	Misure (LxPxA) mm Measures (LxDxH) in	Finitura Finishing	Codice Code
---------------------	-------------------------------	--	-----------------------	----------------



Sistemi di cottura FGB FGB Built in cooking systems



	Sistema di cottura FGB 500 FGB 500 FO built-in cooking system	713 x 575 x 217 mm 28 ¹ / ₈ x 22 ³ / ₄ x 8 ¹ / ₂ in		1085769.1 *
--	---	---	--	--------------------

	Sistema di cottura FGB 500 FO FGB 500 FO built-in cooking system	712 x 615 x 382 mm 28 ¹ / ₈ x 24 ¹ / ₄ x 15 in		1085770.1 *
--	--	--	--	--------------------



Altri sistemi di cottura Other cooking systems



	Smoker WS 450 WS 450 Smoker	434 x 503 x 1010 mm 17 ¹ / ₈ x 19 ³ / ₄ x 39 ³ / ₄ in		1062131.0
--	---------------------------------------	---	--	------------------

	Smoker RF 450 RF 450 Smoker	434 x 503 x 1010 mm 17 ¹ / ₈ x 19 ³ / ₄ x 39 ³ / ₄ in		1075715.0
--	---------------------------------------	---	--	------------------

	Caminetto FFP 950 FFP 950 fireplace	950 x 715 x 1453 mm 37 ³ / ₈ x 28 ¹ / ₈ x 57 ¹ / ₈ in		1077329.0
--	---	---	--	------------------



Accessori smoker e caminetto Smoker and Fireplace accesories

	Set 2 griglie smoker (solo per Smoker WS 450) 2 grids set for Smoker (WS 450 Smoker only)	320 x 380 mm 12 ⁵ / ₈ x 15 in		1064019.0
--	---	---	--	------------------

	Kit reverse flow smoker 450 Reverse flow kit for 450 smoker	500 x 430 mm 19 ⁵ / ₈ x 16 ⁷ / ₈ in		1043541.0
--	---	---	--	------------------

Lares key codes



Prodotto Product	Nome prodotto Product name	Misure (LxPxA) mm Measures (LxDxH) in	Finitura Finishing	Codice Code
---------------------	-------------------------------	--	-----------------------	----------------



	Griglia di cottura inox ffp Stainless steel FFP grill	900 x 430 mm 35 ¹ / ₂ x 16 ⁷ / ₈ in		1074718.0
---	---	---	---	------------------



	Girarrosto elettrico in acciaio Electric steel rotisserie	830 x 395 mm 32 ³ / ₈ x 15 ¹ / ₂ in		1075745.1
---	---	---	---	------------------



Accessori Accesories



	Sistema smaltimento rifiuti Waste disposal system	443 x 304 x 405 mm 17 ³ / ₈ x 12 x 15 ⁷ / ₈ in		1083381.0
---	---	--	---	------------------

	Porta spezie 700 Spice rack 700	700 x 180 mm 27 ¹ / ₂ x 7 ¹ / ₈ in		1088797.0-0001
---	---	--	---	-----------------------

	Porta spezie 1000 Spice rack 1000	1000 x 180 mm 39 ³ / ₈ x 7 ¹ / ₈ in		1088811.0-0001
---	---	---	---	-----------------------

	Ripiano intermedio modulo bbq 500 Intermediate shelf bbq module 500	500 x 520 mm 19 ¹ / ₁₆ x 20 ¹ / ₂ in		1069913.0-E02
---	---	--	---	----------------------

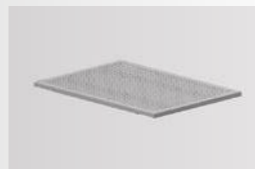









	Ripiano intermedio modulo bbq 750 Intermediate shelf bbq module 750	750 x 520 mm 29 ¹ / ₂ x 20 ¹ / ₂ in		1069911.0-E02
---	---	---	---	----------------------

	Ripiano intermedio modulo bbq 1000 Intermediate shelf bbq module 1000	1000 x 520 mm 39 ³ / ₈ x 20 ¹ / ₂ in		1069914.0-E02
---	---	--	---	----------------------

















Codici di riferimento Lares

Prodotto Product	Nome prodotto Product name	Misure (LxPxA) mm Measures (LxDxH) in	Finitura Finishing	Codice Code
	Cassetto Lares Cassetto + cassettoni Lares Drawer Unit Drawer + Deep Drawer	595x553x622mm 23 ³ / ₈ x 21 ⁹ / ₄ x 24 ¹ / ₂ in		1088833.0-0001
	Cassetto sotto top moduli 700 Under-top drawer for module 700	700 x 500 x 80 mm 27 ¹ / ₂ x 19 ⁵ / ₈ x 3 ¹ / ₈ in		1088798.0-E201 1088798.0-E205
	Cassetto sotto top moduli 1000 Under-top drawer for module 1000	1000 x 500 x 80 mm 39 ³ / ₈ x 19 ⁵ / ₈ x 3 ¹ / ₈ in		1088799.0-E201 1088799.0-E205

Paraschizzi e battistraccio Splashback and upstand

	Paraschizzi modulo 85 Splashback panel module 85	85 x 700 mm 3 ³ / ₈ x 27 ¹ / ₂ in		1088783.0-M200 1088783.0-M100
	Paraschizzi modulo 385 Splashback panel module 385	385 x 700 mm 15 ¹ / ₈ x 27 ¹ / ₂ in		1088784.0-M200 1088784.0-M100
	Paraschizzi modulo 700 Splashback panel module 700	700 x 700 mm 27 ¹ / ₂ x 27 ¹ / ₂ in		1088785.0-M200 1088785.0-M100
	Paraschizzi modulo 1000 Splashback panel module 1000	1000 x 700 mm 39 ³ / ₈ x 27 ¹ / ₂ in		1088786.0-M200 1088786.0-M100
	Paraschizzi modulo Barbecue FGA 500 Splashback panel FGA 500 bbq module	580 x 700 mm 22 ⁷ / ₈ x 27 ¹ / ₂ in		1088787.0-M200 1088787.0-M100

Lares key codes

Prodotto Product	Nome prodotto Product name	Misure (LxPxA) mm Measures (LxDxH) in	Finitura Finishing	Codice Code
	Paraschizzi modulo Barbecue FGA 750 Splashback panel FGA 750 bbq module	830 x 700 mm 32 ⁵ / ₈ x 27 ¹ / ₂ in		1088788.0-M200 1088788.0-M100
	Paraschizzi modulo Barbecue FGA 1000 Splashback panel FGA 1000 bbq module	1080 x 700 mm 42 ¹ / ₂ x 27 ¹ / ₂ in		1088789.0-M200 1088789.0-M100
	Battistraccio modulo 385 Upstand panel module 385	385 x 85 mm 15 ¹ / ₈ x 3 ³ / ₈ in		1088791.0-M200 1088791.0-M100
	Battistraccio modulo 700 Upstand panel module 700	700 x 85 mm 27 ¹ / ₂ x 3 ³ / ₈ in		1088792.0-M200 1088792.0-M100
	Battistraccio modulo 1000 Upstand panel module 1000	1000 x 85 mm 39 ³ / ₈ x 3 ³ / ₈ in		1088793.0-M200 1088793.0-M100
	Battistraccio modulo Barbecue FGA 500 Upstand panel FGA 500 bbq module	580 x 85 mm 22 ⁷ / ₈ x 3 ³ / ₈ in		1088794.0-M200 1088794.0-M100
	Battistraccio modulo Barbecue FGA 750 Upstand panel FGA 750 bbq module	830 x 85 mm 32 ⁵ / ₈ x 3 ³ / ₈ in		1088795.0-M200 1088795.0-M100
	Battistraccio modulo Barbecue FGA 1000 Upstand panel FGA 1000 bbq module	1080 x 85 mm 42 ¹ / ₂ x 3 ³ / ₈ in		1088796.0-M200 1088796.0-M100

Il barbecue in dettaglio

The barbecue in detail

Verniciatura resistente alle intemperie
Bad weather resistant varnishing

Coperchio multifunzione con isolamento
Insulated multi-function lid

Sistema di estrazione dei fumi di combustione
Fume extraction system

Superfici di cottura modulari
Modular cooking surfaces

Fire core: propagazione ottimale del calore
Firecore: optimal heat distribution

Bruciatori ad alta efficienza
High-efficiency burners



Cerniera calibrata con chiusura ammortizzata
Weighted hinge with dampening closing

Termometro con sonda integrata
Thermometer with integrated probe

Manopola di precisione con 210° di rotazione
Precision knob with 210° rotation

Cassetto recupero liquidi di cottura
Drip tray for cooking liquids

Accensione del fuoco elettronica
Electronic ignition

Guarnizione a tenuta ermetica
Hermetically sealing gasket

Lo smoker in dettaglio

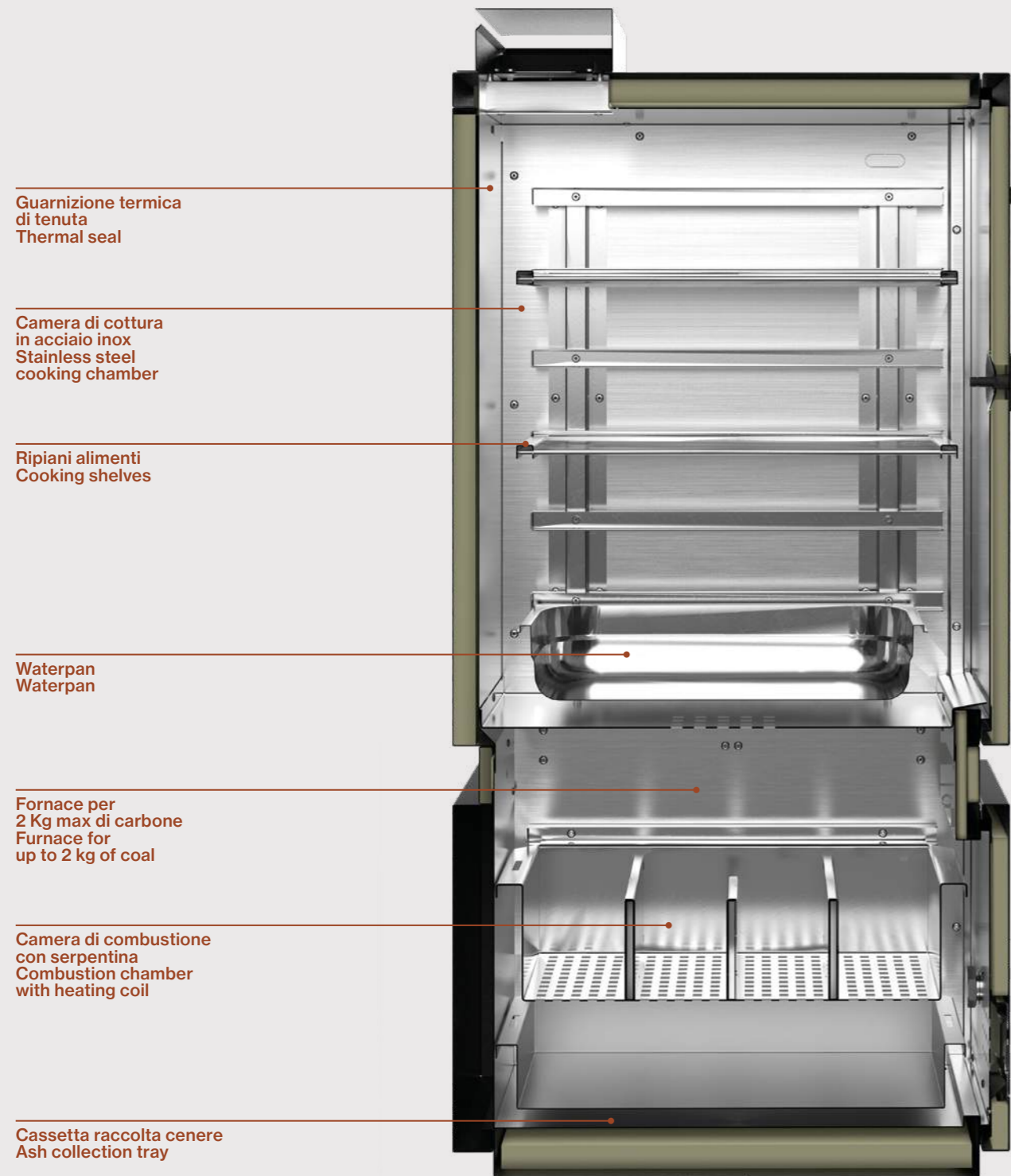

The smoker in detail

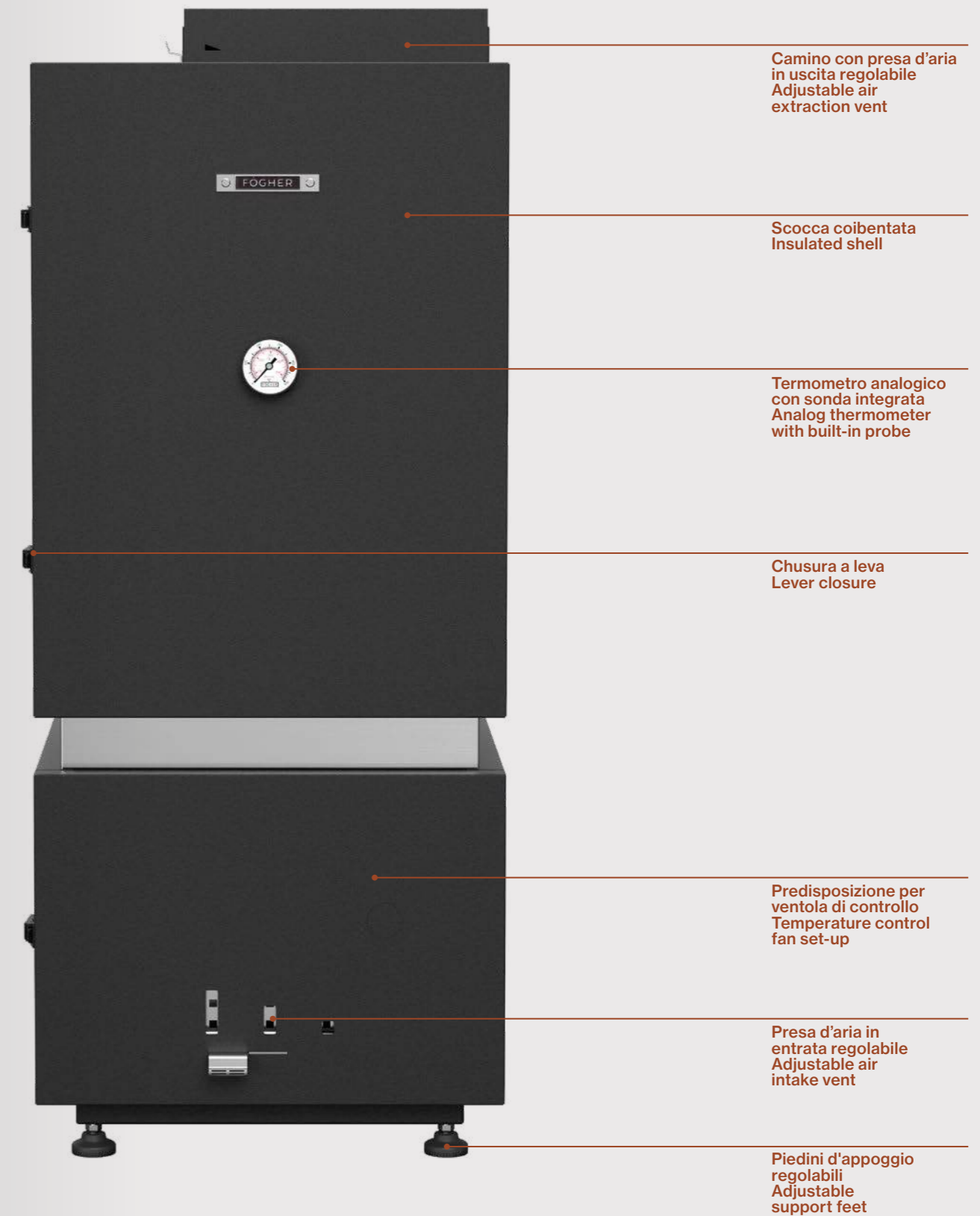

Il caminetto in dettaglio

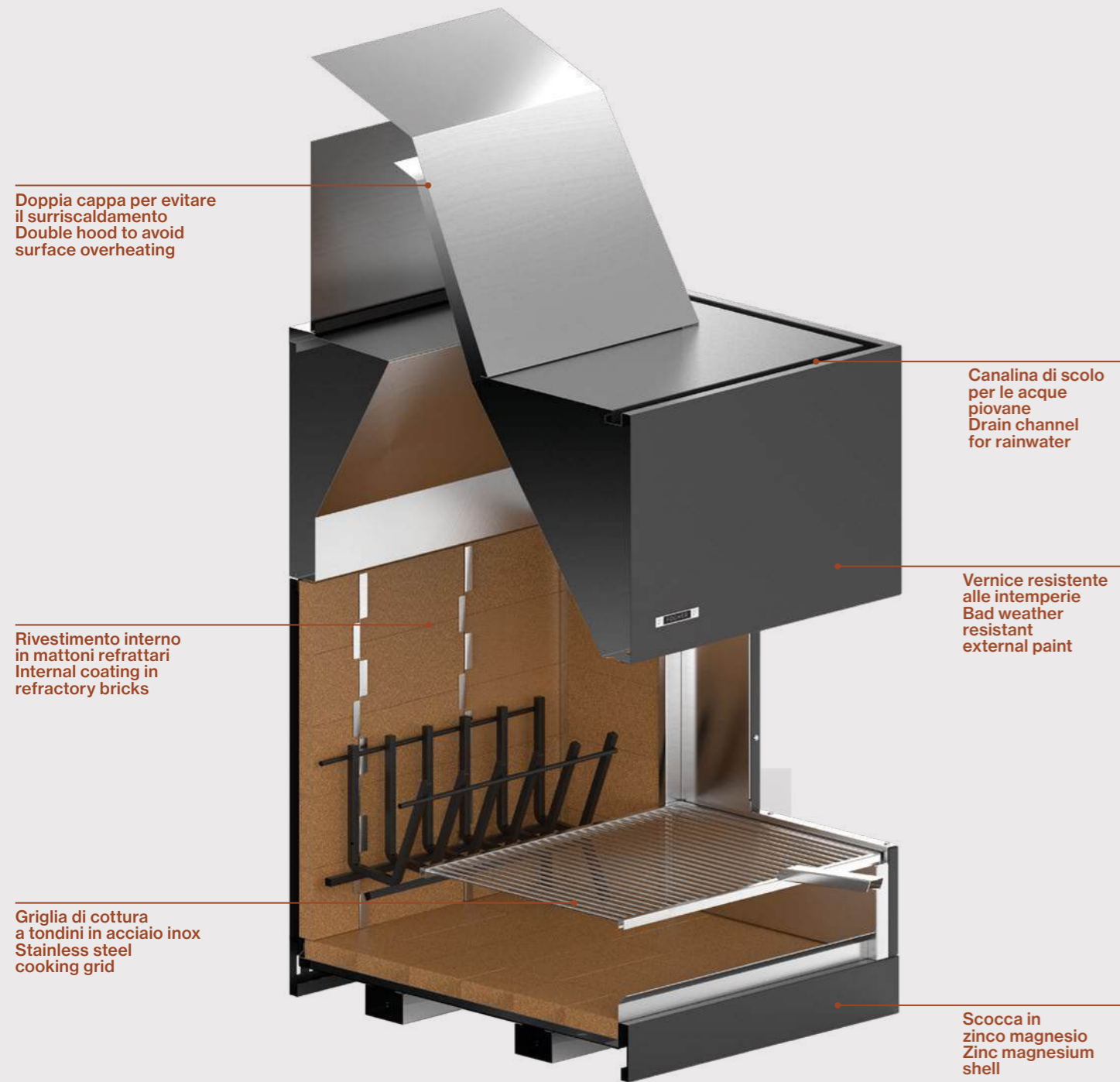



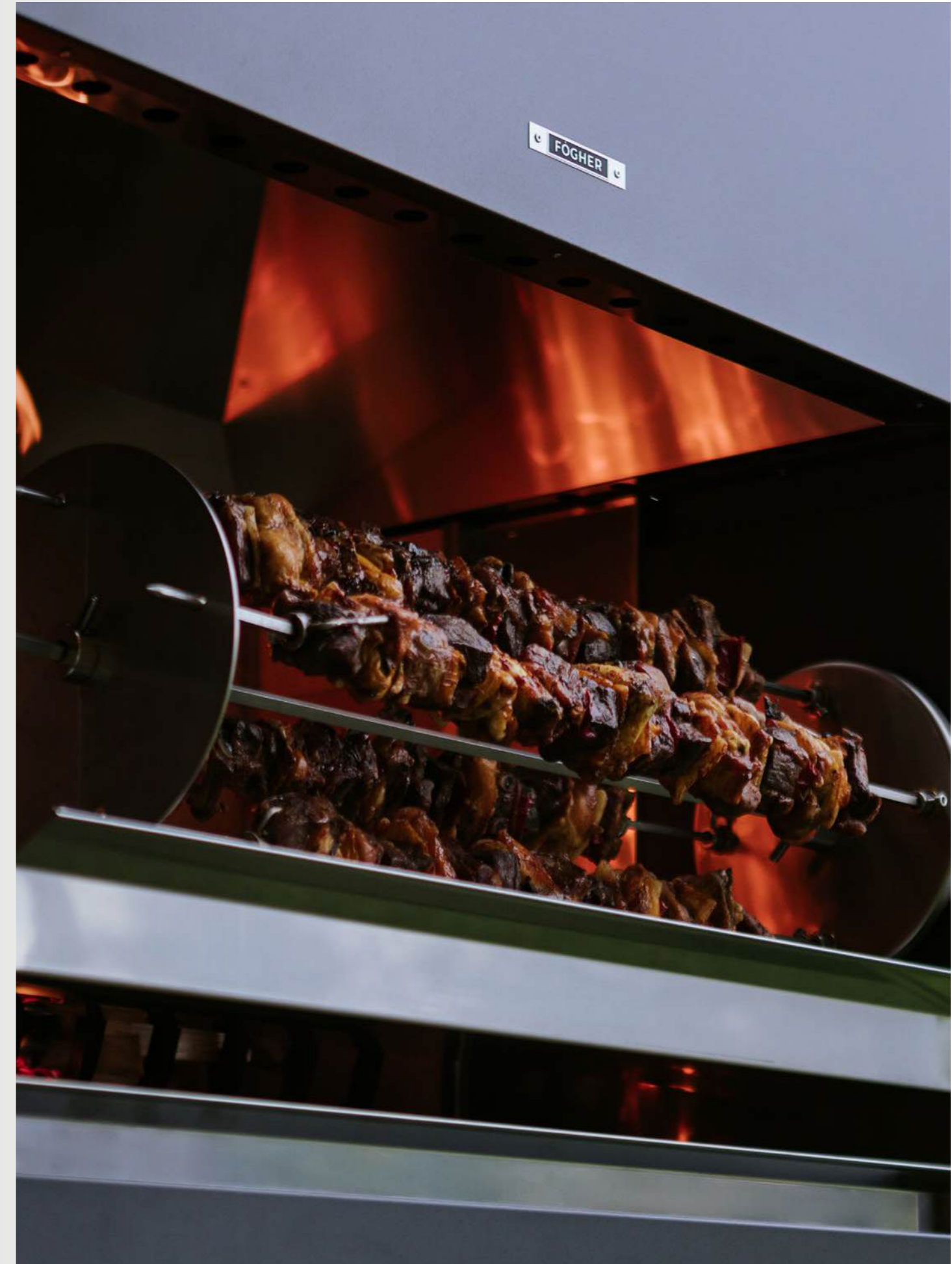









The fireplace in detail





Codici di riferimento Sistemi di cottura

Prodotto Product	Nome prodotto Product name	Misure (LxPxA) mm Measures (LxDxH) in	Finitura Finishing	Codice Code
---------------------	-------------------------------	--	-----------------------	----------------

Sistemi di cottura FGA FGA cooking systems











	Sistema di cottura FGA 500 FGA 500 cooking system	550 x 590 x 259 mm 21 7/8 x 23 1/4 x 10 1/4 in		1085764.1 *
	Sistema di cottura FGA 750 FGA 750 cooking system	800 x 590 x 259 mm 31 1/2 x 23 1/4 x 10 1/4 in		1085765.1 *
	Sistema di cottura FGA 1000 FGA 1000 cooking system	1051 x 590 x 259 mm 17 3/4 x 20 1/2 x 10 1/4 in		1085768.1 *
	Sistema di cottura FGA 500 FO FGA 500 FO cooking system	550 x 520 x 424 mm 21 5/8 x 20 1/2 x 16 3/4 in		1085763.1 *
	Sistema di cottura FGA 750 FO FGA 750 FO cooking system	800 x 520 x 424 mm 31 1/2 x 20 1/2 x 16 3/4 in		1085765.1 *
	Sistema di cottura FGA 1000 FO FGA 1000 FO cooking system	1051 x 520 x 424 mm 41 3/8 x 20 1/2 x 16 3/4 in		1085767.1 *

Sistemi di cottura ad incasso FGB FGB built in cooking systems





	Sistema di cottura FGB 500 FGB 500 FO built-in cooking system	713 x 575 x 217 mm 28 1/8 x 22 3/4 x 8 1/2 in		1085769.1 *
--	--	--	--	-------------

Cooking systems key codes

Prodotto Product	Nome prodotto Product name	Misure (LxPxA) mm Measures (LxDxH) in	Finitura Finishing	Codice Code
---------------------	-------------------------------	--	-----------------------	----------------

	Sistema di cottura FGB 750 FGB 750 built-in cooking system	963 x 575 x 217 mm 37 7/8 x 22 3/4 x 8 1/2 in		1085771.1 *
	Sistema di cottura FGB 1000 FGB 1000 built-in cooking system	1213 x 575 x 217 mm 47 7/8 x 22 3/4 x 8 1/2 in		1085771.1 *
	Sistema di cottura FGB 500 FO FGB 500 FO built-in cooking system	712 x 615 x 382 mm 28 1/8 x 24 1/4 x 15 in		1085773.1 *
	Sistema di cottura FGB 750 FO FGB 750 FO built-in cooking system	963 x 615 x 382 mm 37 7/8 x 24 1/4 x 15 in		1085772.1 *
	Sistema di cottura FGB 1000 FO FGB 1000 FO built-in cooking system	1213 x 615 x 382 mm 47 7/8 x 24 1/4 x 15 in		1085774.1 *



Smoker Smoker

	Smoker WS 450 WS 450 Smoker	434 x 503 x 1010 mm 17 1/8 x 19 3/4 x 39 3/4 in		1062131.0
	Smoker RF 450 RF 450 Smoker	434 x 503 x 1010 mm 17 1/8 x 19 3/4 x 39 3/4 in		1075715.0

Codici di riferimento Sistemi di cottura

Prodotto Product	Nome prodotto Product name	Misure (LxPxA) mm Measures (LxDxH) in	Finitura Finishing	Codice Code
---------------------	-------------------------------	--	-----------------------	----------------



Caminetto Fireplace



	Caminetto FFP 950 FFP 950 fireplace	950 x 715 x 1453 mm 37 ⁷ / ₈ x 28 ¹ / ₈ x 57 ¹ / ₈ in		1077329.0
--	---	---	--	------------------



Accessori sistemi di cottura BBQ Cooking systems BBQ accessories



	Fry top Fry top	250 x 430 mm 9 ⁷ / ₈ x 16 ¹⁵ / ₁₆ in		1068682.0
--	---------------------------	--	--	------------------

	Griglia doppia in acciaio inox Double grill	250 x 430 mm 9 ⁷ / ₈ x 16 ¹⁵ / ₁₆ in		1051116.0
--	---	--	--	------------------

	Pietra ollare Soapstone	250 x 430 mm 9 ⁷ / ₈ x 16 ¹⁵ / ₁₆ in		1059050.0
--	-----------------------------------	--	--	------------------

	Brasiera 500 Teppan 500	500 x 420 mm 19 ⁵ / ₈ x 16 ¹ / ₂ in		1082290.0
--	-----------------------------------	---	--	------------------



	Brasiera 750 Teppan 750	750 x 420 mm 29 ¹ / ₂ x 16 ¹ / ₂ in		1082289.0
--	-----------------------------------	---	--	------------------



	Kit cottura indiretta 250 Indirect cooking kit 250	250 x 430 mm 9 ⁷ / ₈ x 16 ¹⁵ / ₁₆ in		1070935.0
--	--	--	--	------------------



Cooking systems key codes

Prodotto Product	Nome prodotto Product name	Misure (LxPxA) mm Measures (LxDxH) in	Finitura Finishing	Codice Code
---------------------	-------------------------------	--	-----------------------	----------------

	Kit cottura indiretta 500+ Affumicatore Indirect cooking/smoking kit 500	500 x 430 mm 19 ⁵ / ₈ x 16 ¹⁵ / ₁₆ in		1070934.0
---	--	---	---	------------------



	Kit panificazione 500 Baking kit 500	497 x 430 mm 19 ¹ / ₂ x 16 ¹⁵ / ₁₆ in		1070730.0
---	--	---	---	------------------



	Kit panificazione 750 Baking kit 750	743 x 430 mm 29 ¹ / ₄ x 16 ¹⁵ / ₁₆ in		1070736.0
---	--	---	---	------------------

	Kit panificazione 1000 Baking kit 1000	989 x 430 mm 38 ¹⁵ / ₁₆ x 16 ¹⁵ / ₁₆ in		1070740.0
--	--	---	---	------------------

	Kit panificazione / Scaldavivande Baking trays / chafing dish	494 x 374 mm 19 ⁷ / ₁₆ x 16 ¹⁵ / ₁₆ in		1067263.0
---	---	--	---	------------------

Accessori smoker Smoker accessories

	Set 2 griglie smoker (solo per Smoker WS 450) 2 grids set for Smoker (WS 450 Smoker only)	320 x 380 mm 12 ⁵ / ₈ x 15 in		1064019.0
---	---	---	---	------------------

	Kit reverse flow smoker 450 Reverse flow kit for 450 smoker	500 x 430 mm 19 ⁵ / ₈ x 16 ⁷ / ₈ in		1043541.0
---	---	---	---	------------------

Codici di riferimento Sistemi di cottura

Prodotto Product	Nome prodotto Product name	Misure (LxPxA) mm Measures (LxDxH) in	Finitura Finishing	Codice Code
---------------------	-------------------------------	--	-----------------------	----------------



Kit ruote smoker 450
Smoker 450 wheel kit

1059177.0

Accessori caminetto Fireplace accessories



Griglia di cottura inox FFP
Stainless steel FFP grill

900 x 430 mm
35½ x 16 7/8 in

1074718.0

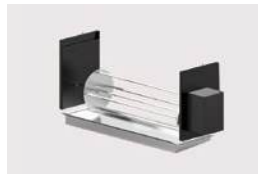

Girarrosto elettrico in acciaio
Electric steel rotisserie

830 x 395 mm
32 3/8 x 15 1/2 in

1075745.1

Piani cottura Cooking appliances



FEL 453 ST
Piano cottura induzione Lùxar 3 zone
FEL 453 ST
Lùxar Induction cooktop 3 zones

450 x 520 mm
17 3/4 x 20 1/2 in

1084215.1 *



FEF 4514 SE
Piano cottura gas Fiuma 1 fuoco dual
FEF 4514 SE
Fiuma gas cooktop 1 dual burner

450 x 520 mm
17 3/4 x 20 1/2 in

1084508.1 *



FEF 4532 SE
Piano cottura gas Fiuma 3 fuochi
FEF 4532 SE
Fiuma gas cooktop 3 burners







450 x 520 mm
17 3/4 x 20 1/2 in

1084501.1 *









Cooking systems key codes

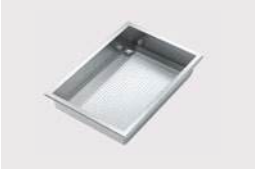

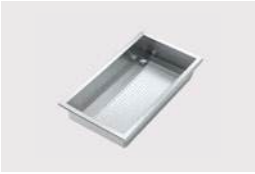



Codici di riferimento Lavelli

Prodotto Product	Nome prodotto Product name	Misure (LxPxA) mm Measures (LxDxH) in	Finitura Finishing	Codice Code
	FEY 450 NA Lavello Yòza FEY 450 NA Yòza Sink	440 x 510 mm 17 ³ / ₈ x 20 ¹ / ₈ in		1089742.0
	FEY 450 UT Lavello Yòza FEY 450 UT Yòza Sink	440 x 500 mm 17 ³ / ₈ x 19 ⁵ / ₈ in		1084796.0
	FEY 950 ST Sistema lavello Yòza FEY 950 ST Yòza Sink System	970 x 530 x 230 mm 38 ³ / ₁₆ x 20 ⁷ / ₈ x 9 in		1084797.0

Accessori lavello FEY 950 ST Cooking appliances

	Vaschetta forata grande Large strainer tray	345 x 435 x 80 mm 11 ⁷ / ₈ x 17 ¹ / ₈ x 3 ¹ / ₈ in		1084230.0
	Vaschetta forata piccola Small strainer tray	190 x 435 x 80 mm 7 ¹ / ₂ x 17 ¹ / ₈ x 3 ¹ / ₈ in		1084233.0
	Griglia Grill	300 x 465 x 25 mm 11 ⁷ / ₈ x 18 ³ / ₁₆ x 1 in		1084232.0
	Vaschetta Tray	345 x 435 x 80 mm 11 ⁷ / ₈ x 17 ¹ / ₈ x 3 ¹ / ₈ in		1084231.0

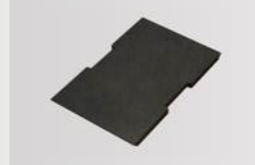











Sink key codes

Prodotto Product	Nome prodotto Product name	Misure (LxPxA) mm Measures (LxDxH) in	Finitura Finishing	Codice Code
	Tagliere in legno Wood cutting board	345 x 465 x 19 mm 11 ⁷ / ₈ x 18 ³ / ₁₆ x ³ / ₄ in		1084234.0
	Tagliere in Paperstone® Paperstone® cutting board	345 x 465 x 19 mm 11 ⁷ / ₈ x 18 ³ / ₁₆ x ³ / ₄ in		1084235.0



Codici di riferimento Free standing

Prodotto Product	Nome prodotto Product name	Misure (LxPxA) mm Measures (LxDxH) in	Finitura Finishing	Codice Code
---------------------	-------------------------------	--	-----------------------	----------------

Configurazioni FGA FO FGA FO configuration



	Barbecue free standing FKS 003 FKS 003 free standing barbecue	551 x 590 x 1120 mm 21 ⁵ / ₈ x 23 ¹ / ₄ x 44 ¹ / ₈ in		1076478.1*
	Barbecue free standing FKS 005 FKS 005 free standing barbecue	800 x 590 x 1120 mm 31 ¹ / ₂ x 23 ¹ / ₄ x 44 ¹ / ₈ in		1076480.1*
	Barbecue free standing FKS 007 FKS 007 free standing barbecue	1051 x 590 x 1120 mm 41 ³ / ₈ x 23 ¹ / ₄ x 44 ¹ / ₈ in		1076482.1*
	Barbecue free standing FKS 004 FKS 004 free standing barbecue	551 x 590 x 1120 mm 21 ⁵ / ₈ x 23 ¹ / ₄ x 44 ¹ / ₈ in		1085115.1-E02*
	Barbecue free standing FKS 006 FKS 006 free standing barbecue	800 x 590 x 1120 mm 31 ¹ / ₂ x 23 ¹ / ₄ x 44 ¹ / ₈ in		1085116.1-E02*
	Barbecue free standing FKS 008 FKS 008 free standing barbecue	1051 x 590 x 1120 mm 41 ³ / ₈ x 23 ¹ / ₄ x 44 ¹ / ₈ in		1085117.1-E02*

Configurazioni FGA FGA configuration













	Barbecue free standing FKS 001 FKS 001 free standing barbecue	551 x 590 x 1120 mm 21 ⁵ / ₈ x 23 ¹ / ₄ x 44 ¹ / ₈ in		1076476.1*
--	--	--	--	------------

Free standing key codes







Prodotto Product	Nome prodotto Product name	Misure (LxPxA) mm Measures (LxDxH) in	Finitura Finishing	Codice Code
---------------------	-------------------------------	--	-----------------------	----------------

	Barbecue free standing FKS 002 FKS 002 free standing barbecue	800 x 590 x 1120 mm 31 ¹ / ₂ x 23 ¹ / ₄ x 44 ¹ / ₈ in		1076477.1*
---	--	--	---	------------







Supporto BBQ Free standing BBQ free standing support

	Gambe tubolari fisse 500 Fixed tubular legs 500	532 x 479 x 700 mm 20 ⁷ / ₈ x 18 ⁷ / ₈ x 27 ¹ / ₂ in		1070065.0
	Gambe tubolari fisse 750 Fixed tubular legs 750	782 x 479 x 700 mm 30 ⁷ / ₈ x 18 ⁷ / ₈ x 27 ¹ / ₂ in		1070066.0
	Gambe tubolari fisse 1000 Fixed tubular legs 1000	1033 x 479 x 700 mm 40 ⁵ / ₈ x 18 ⁷ / ₈ x 27 ¹ / ₂ in		1070067.0
	Kit carrello leggero 500 sx/dx Cart BBQ 500 L/R	791 x 508 x 700 mm 31 ¹ / ₈ x 20 x 27 ¹ / ₂ in		1085112.0-E02t
	Kit carrello leggero 750 sx/dx Cart BBQ 750 L/R	1041 x 508 x 700 mm 41 x 20 x 27 ¹ / ₂ in		1085113.0-E02
	Kit carrello leggero 1000 sx/dx Cart BBQ 1000 L/R	1292 x 508 x 700 mm 50 ⁷ / ₈ x 20 x 27 ¹ / ₂ in		1085114.0-E02

Codici di riferimento Free standing

Prodotto Product	Nome prodotto Product name	Misure (LxPxA) mm Measures (LxDxH) in	Finitura Finishing	Codice Code
	Kit carenatura gambe carrello 500 Doors kit for legs cart BBQ 500	551 x 590 x 1120 mm 21 ⁷ / ₈ x 23 ¹ / ₄ x 44 ¹ / ₈ in		1083541.0-E02
	Kit carenatura gambe carrello 750 Doors kit for legs cart BBQ 750	800 x 590 x 1120 mm 31 ¹ / ₂ x 23 ¹ / ₄ x 44 ¹ / ₈ in		1083540.0-E02
	Kit carenatura gambe carrello 1000 Doors kit for legs cart BBQ 1000	1051 x 590 x 1120 mm 41 ³ / ₈ x 23 ¹ / ₄ x 44 ¹ / ₈ in		1083539.0-E02

Configurazioni caminetto Fireplace configurations

	Caminetto free standing FKS 009 FKS 009 free standing fireplace	950 x 715 x 2153 mm 37 ³ / ₈ x 28 ¹ / ₈ x 84 ¹ / ₈ in		1077324.0
	Caminetto free standing FKS 010 FKS 010 free standing fireplace	950 x 715 x 2153 mm 37 ³ / ₈ x 28 ¹ / ₈ x 84 ¹ / ₈ in		1076484.0
	Caminetto free standing FKS 011 FKS 011 free standing fireplace	950 x 715 x 2153 mm 37 ³ / ₈ x 28 ¹ / ₈ x 84 ¹ / ₈ in		1077325.0

Free standing Key codes



Codici di riferimento Coperture

Prodotto Product	Nome prodotto Product name	Misure (LxPxA) mm Measures (LxDxH) in	Finitura Finishing	Codice Code
---------------------	-------------------------------	--	-----------------------	----------------

Coperture Agher Agher cover

	Copertura cucina isola Agher Agher island kitchen cover	2400 x 600 x 1310 mm 94½ x 23¾ x 51½ in		1082439.0
--	---	---	--	------------------

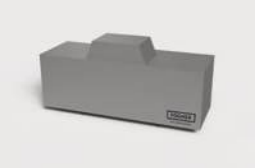
	Copertura cucina con Snack bar Agher Agher kitchen cover with serving bar	2400 x 780 x 1310 mm 94½ x 30¾ x 51½ in		1082440.0
--	---	---	--	------------------

Coperture barbecue FGB FGB barbecue cover

	Copertura barbecue FGB 500 FGB 500 magnetic barbecue cover			1083937.0
--	--	--	--	------------------

	Copertura barbecue FGA 750 FGB 750 magnetic barbecue cover			1083939.0
--	--	--	--	------------------

	Copertura barbecue FGB 1000 FGB 100 magnetic barbecue cover			1083941.0
--	---	--	--	------------------

	Copertura barbecue FGB 500 FO FGB 500 FO magnetic barbecue cover			1083938.0
--	--	--	--	------------------

	Copertura barbecue FGB 750 FO FGB 750 FO magnetic barbecue cover			1083940.0
--	--	--	--	------------------

	Copertura barbecue FGB 1000 FO FGB 1000 FO magnetic barbecue cover			1083942.0
--	--	--	--	------------------

Cover Key codes

Prodotto Product	Nome prodotto Product name	Misure (LxPxA) mm Measures (LxDxH) in	Finitura Finishing	Codice Code
---------------------	-------------------------------	--	-----------------------	----------------

Coperture barbecue FGA FGA barbecue cover

	Copertura barbecue FGA 500 FGA 500 magnetic barbecue cover			1082461.0
---	--	--	--	------------------

	Copertura barbecue FGA 750 FGA 750 magnetic barbecue cover			1082463.0
---	--	--	--	------------------

	Copertura barbecue FGA 1000 FGA 1000 magnetic barbecue cover			1082465.0
---	--	--	--	------------------

	Copertura barbecue FGA 500 FO FGA 500 FO magnetic barbecue cover			1082462.0
--	--	--	--	------------------

	Copertura barbecue FGA 750 FO FGA 750 FO magnetic barbecue cover			1082464.0
---	--	--	--	------------------

	Copertura barbecue FGA 1000 FO FGA 1000 FO magnetic barbecue cover			1082466.0
---	--	--	--	------------------

Coperture tavolo Table cover

	Copertura tavolo Table cover	1600 x 780 mm 63 x 30¾ in		1082441.0
---	--	-------------------------------------	--	------------------

Tabella di conversione modelli e certificati

Nome prodotto Product name	CE (1)	UL (3)
Barbecue FGA 500 FGA 500 barbecue	1085764.1	1085764.3
Barbecue FGA 750 FGA 750 barbecue	1085765.1	1085765.3
Barbecue FGA 1000 FGA 1000 barbecue	1085768.1	1085768.3
Barbecue FGA 500 FO FGA 500 FO barbecue	1085763.1	1085763.3
Barbecue FGA 750 FO FGA 750 FO barbecue	1085765.1	1085765.3
Barbecue FGA 1000 FO FGA 1000 FO barbecue	1085767.1	1085767.3
Barbecue FGB 500 FGB 500 built-in barbecue	1085769.1	1085769.3
Barbecue FGB 750 FGB 750 built-in barbecue	1085771.1	1085771.3
Barbecue FGB 1000 FGB 1000 built-in barbecue	1085773.1	1085773.3
Barbecue FGB 500 FO FGB 500 FO built-in barbecue	1085770.1	1085770.3
Barbecue FGB 750 FO FGB 750 FO built-in barbecue	1085772.1	1085772.3
Barbecue FGB 1000 FO FGB 1000 FO built-in barbecue	1085774.1	1085774.3
FEL 453 ST - Piano cottura induzione Lùxar 3 zone FEL 453 ST - Lùxar Induction cooktop 3 zones	1084215.1	-
FEF 4514 SE - Piano cottura gas Fiamma 1 fuoco dual FEF 4514 SE - Fiamma gas cooktop 1 dual burner	1084508.1	1084508.3
FEF 4532 SE - Piano cottura gas Fiamma 3 fuochi FEF 4532 SE - Fiamma gas cooktop 3 burners	1084501.1	1084501.3
Frigo outdoor e kit per incasso (Lares) Outdoor refrigerator with built-in kit (Lares)	1088771.1	1088771.3
Cantinetta vini outdoor e kit per incasso (Lares) Outdoor wine cooler with built-in kit (Lares)	1088773.1	1088773.3
Frigo outdoor e kit per incasso (Agher) Outdoor refrigerator with built-in kit (Agher)	1084601.1	1084601.3
Cantinetta vini outdoor e kit per incasso (Agher) Outdoor wine cooler with built-in kit (Agher)	1088805.1	1088805.3
Fabbricatore ghiaccio nautico - Inox AISI 316 Marine ice maker - AISI 316 stainless steel	1084815.1	1084815.3
Barbecue free standing FKS 003 Barbecue free standing FKS 003	1076478.1	1076478.3
Barbecue free standing FKS 005 Barbecue free standing FKS 005	1076480.1	1076480.3
Barbecue free standing FKS 007 Barbecue free standing FKS 007	1076482.1	1076482.3
Barbecue free standing FKS 004 Barbecue free standing FKS 004	1085115.1	1085115.3
Barbecue free standing FKS 006 Barbecue free standing FKS 006	1085116.1	1085116.3
Barbecue free standing FKS 008 Barbecue free standing FKS 008	1085117.1	1085117.3
Barbecue free standing FKS 001 Barbecue free standing FKS 001	1076476.1	1076476.3
Barbecue free standing FKS 002 Barbecue free standing FKS 002	1076477.1	1076477.3

Conversion table for models and certifications

Dai forma alla tua cucina. Configurala ora: fogher.com
Shape your kitchen. Configure it now: fogher.com

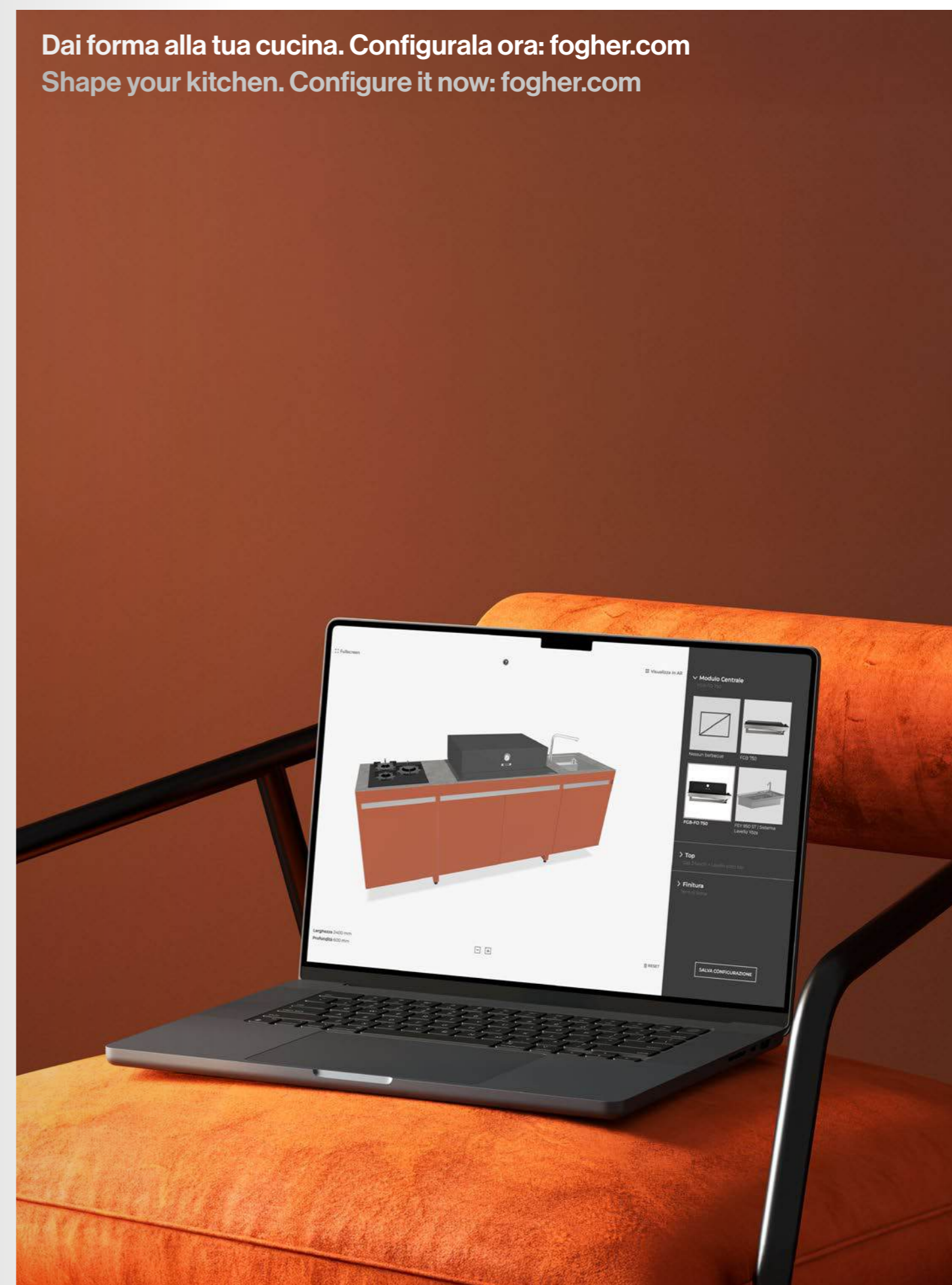

Più di una semplice cucina

Beyond a simple kitchen

Fògher is a trademark Deimos 2022©,
DEIMOS srl All rights reserved.

Via Cavassico Inferiore, 1
Località Trichiana
32026, Borgo Valbelluna (BL) - ITALY

P.IVA e C.F. 00847230257

T (+39) 0437 8066
F (+39) 0437 806699

info@fogher.com
fogher.com

Graphic design + Art direction:
Toni Cancian

Set design:
Elisa Costantino

Rendering:
NOM Bureau

Print:
Grafiche Antiga in 2026

CAE20.04.0098.ITA-ENG

