

Le Bambole

50th Anniversary

design Mario Bellini

Le Bambole 50th Anniversary - 40 / 89



B&B Italia presents
Le Bambole [the dolls]
by Mario Bellini, in a
radically renewed version
perfectly aligned with
the most important and
contemporary trends of
colors and style.

Fifty years after their
initial creation, these
icons of Italian style
are evolving thanks
to new design choices
that make them even
more comfortable and
increasingly sustainable.

B&B
ITALIA

Social background and heritage

The '60s and '70s were fundamental years for Italian women and not only; they were key decades for their emancipation and their rights, in tune with great cultural and social movements that were spreading all over the world.

Cinema, music, art, fashion and communication began to present an image of an increasingly emancipated woman, master of her own appearance.



Who often used her body in total autonomy, as a weapon of seduction or as a claim to her own strength, as an instrument of conquest or as a declaration of independence.



The launch advertising campaign made history in communication and design.

Donna Jordan dances and she looks relaxed and happy, next to or nestled in Le Bambole.

Le Bambole were the subject of a shoot by Oliviero Toscani, who photographed Donna Jordan, a model best known for her work at Andy Warhol's Factory.

The advertising campaign was very disruptive and broke the communication codes of this sector.



The images were revealed for the first time in the corridors of the 1972 Salone del Mobile and were immediately censored.

Compasso d'Oro

Le Bambole are one of the best-sellers protagonists of Italian and international design and in 1979 were awarded with the Compasso d'Oro.



Design Concept



Design Concept

Inspired by traditional rag dolls, Le Bambole are presented as a series of large cushions arranged in an almost random manner, in line with the transformations of living in progress at the beginning of the '70s.

Generous paddings built with fabric and with no internal rigid frames where all the traditional construction elements melt all in one were the real intentions of the designer that was willing to reproduce "a living body pleasant to touch and embrace, soft but safe"

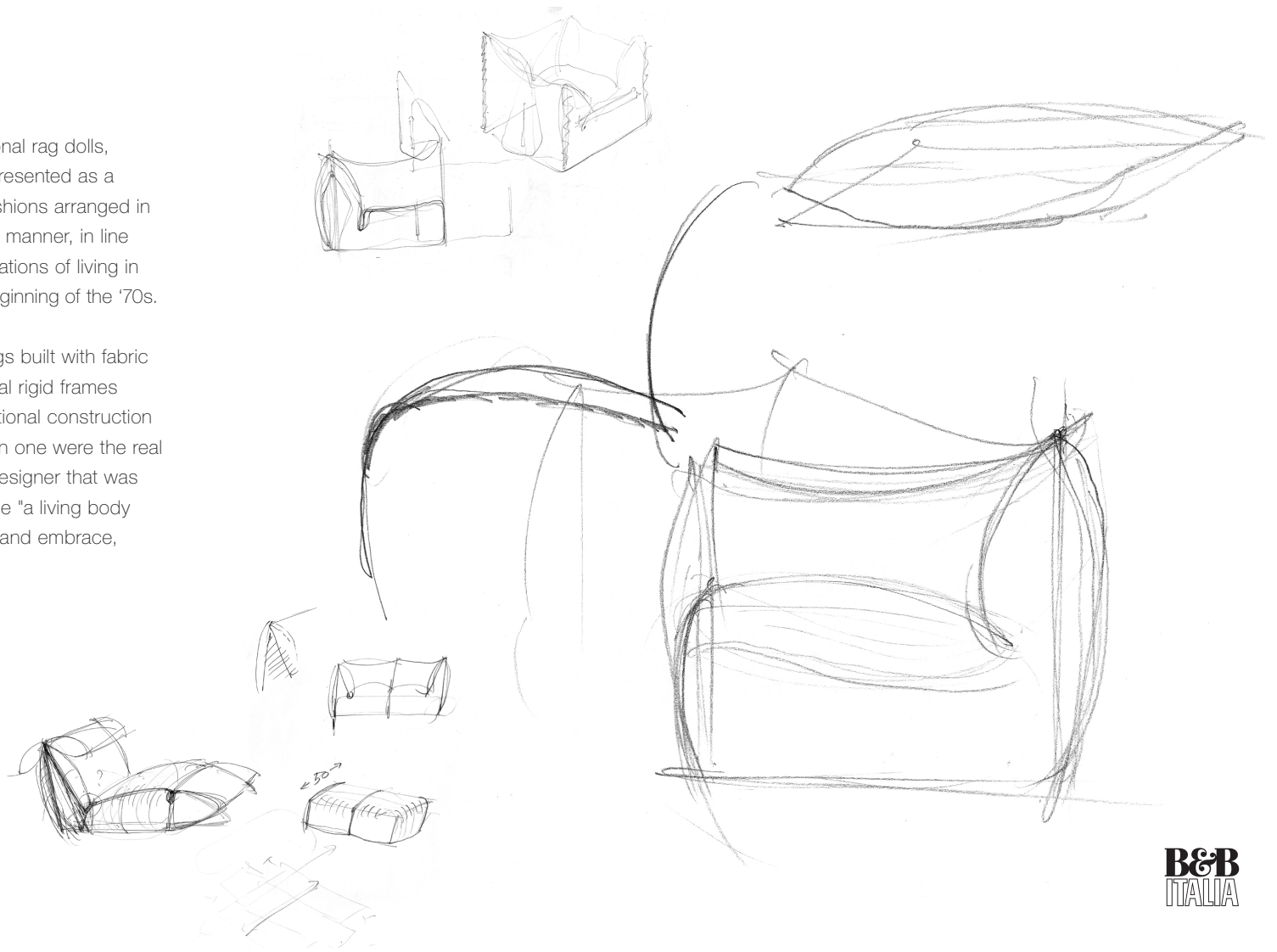

Design Concept

Mario Bellini's clear idea was to revamp the body of upholstered furniture where cushion takes the lead and create one global soft mass that generates sofas, armchairs, dormeuse, pouff and beds.

It is in its own way the idea of "denude" the sofa, which is no longer a wealthy-status symbol but a playful element in the panorma of the furniture.



Design Concept

Le Bambole had an internal frame without rigid supports, springs and belts that were replaced by four hardened polyurethane vertical elements connected to a metal frame that creates resistance while granting at the same time a high level of elasticity.

Paddings realized with layers of different densities of polyurethane wrapped in fabric completes the structure of the product structural body of the product.

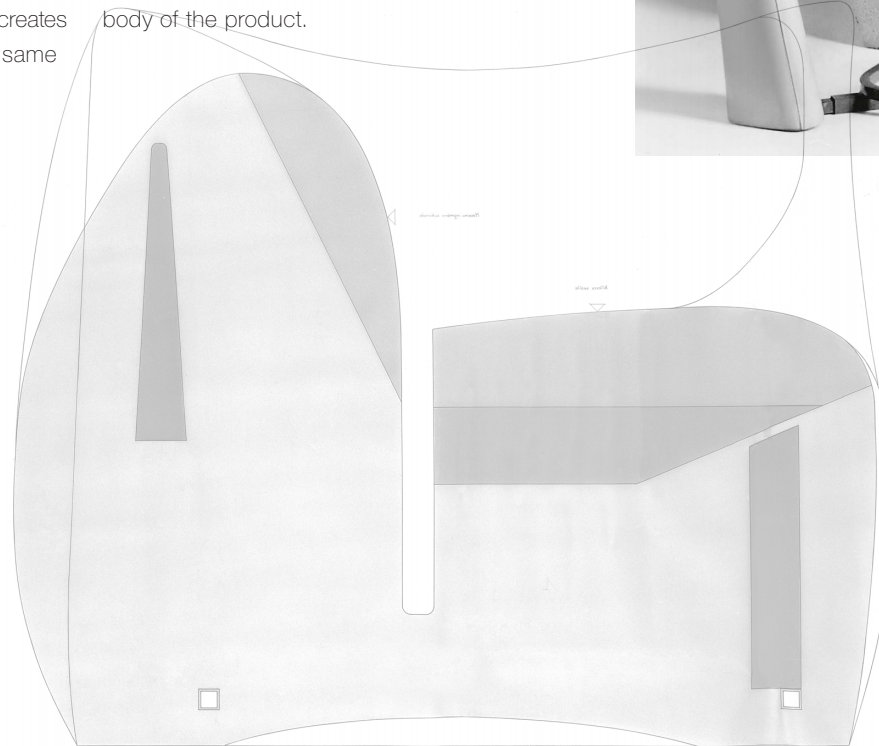

Le Bambole

50th Anniversary



1972

2022



“

I feel the pleasure of revisiting this family again, because it confirms to me that it is anything but aged; on the contrary, it is enjoying a thriving and promising second life, a rebirth done in a big way, done with enthusiasm, with breadth, with decorations and with the original flourishes. We have recovered its charm, its sumptuous floridity, its softness.

”

Mario Bellini

An ode to softness, comfort and sustainability.

The revamped version recaptures
a look and feel more akin to the
original, favouring generous, curvy,
increasingly feminine shapes.



The collection



Bamb



ola



Ba



mbobola

Bamb



ola



Bilbam



ibola

Granbata



mbola

Granbambola

Le Bambole 50th Anniversary - 59 / 89



The new three-seater sofa with a deeper seat, that has earned it the name Granbambola and that aligns more with the new living needs.

B&B
ITALIA

Bai



mbooletto

Bamboletto

The back cushion can be placed in different positions and used as soft support. Thanks to a smart zip it could also be removed.

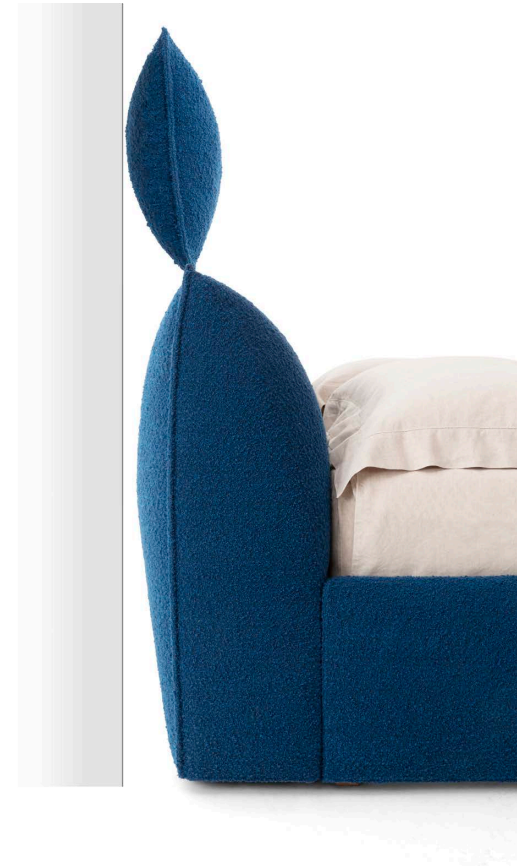

Comfort

Throughout their history, Le Bambole have seen slight adaptations in shape and construction techniques, proving that they are always able to keep up with the times.

Comfort is a key element of the design and it is guaranteed by a series of clever construction measures despite the fact that the amount of polyurethane used is considerably less.

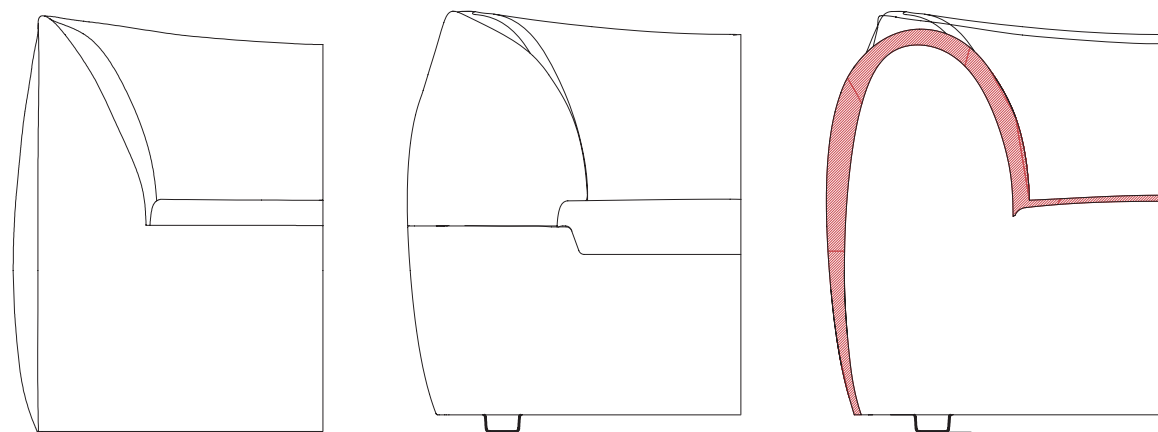

LE BAMBOLE '07

LE BAMBOLE 50TH ANNIVERSARY

COMPARISON IN SECTION

Sustainability

B&B Italia continues its commitment to developing always more sustainable products.

Today's challenge is to produce circular products, considering these as part of a cycle that include our lives and the environment around us.

Materials choices and construction details are confirming Le Bambole as an epitome of sustainability.



100%
disassemblability

c.a.
80%
circularity

Sustainability

Whereas in the original construction there was a metal frame drowned into polyurethane, this material is now reduced to a minimum to leave space for latest generations materials.

Recycled polyethylene is now used for the structure while polyurethane and thermoplastic elastomers define geometries and allow comfort and breathability.

A from 100% recycled polyethylene undercover wraps all these materials together.



>50%
input-output
recycling materials

Technical details

Bambola

LBA1

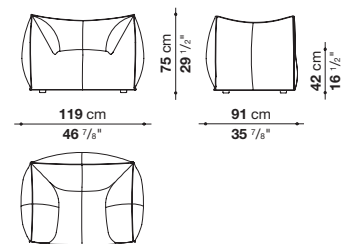

Bibambola

LBA2

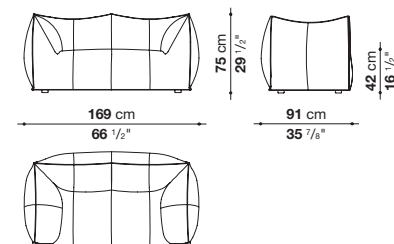

Granbambola

LBA3

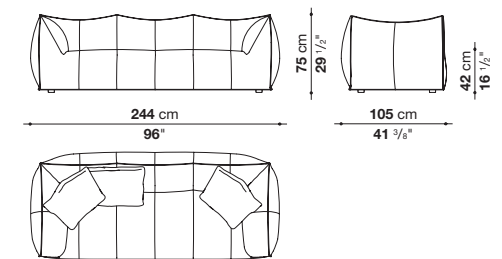

Bamboletto

LBL

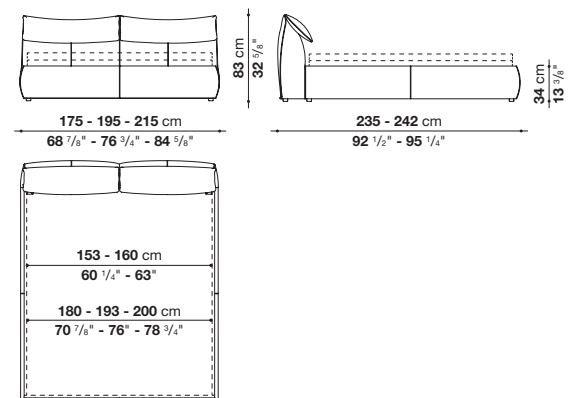

Technical details

Logo printed in silk-screen printing on jute placement under the product

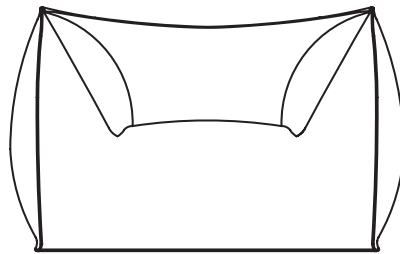

B&B | **Le Bambole** |
ITALIA | design Mario Bellini | Made in Italy



B&B | **Le Bambole** |
ITALIA | design Mario Bellini | Made in Italy

The Outfits



Fabric plays an important role in this project, since it compresses the volumes and contributes to define them. Objects are therefore sensual visions that convey a sense of pleasure.

More than ever, B&B Italia has worked to create a strong connection between the product, an armchair or a sofa, and the person who is sitting or relaxing on it.

Between tactile pleasure and ironic touches

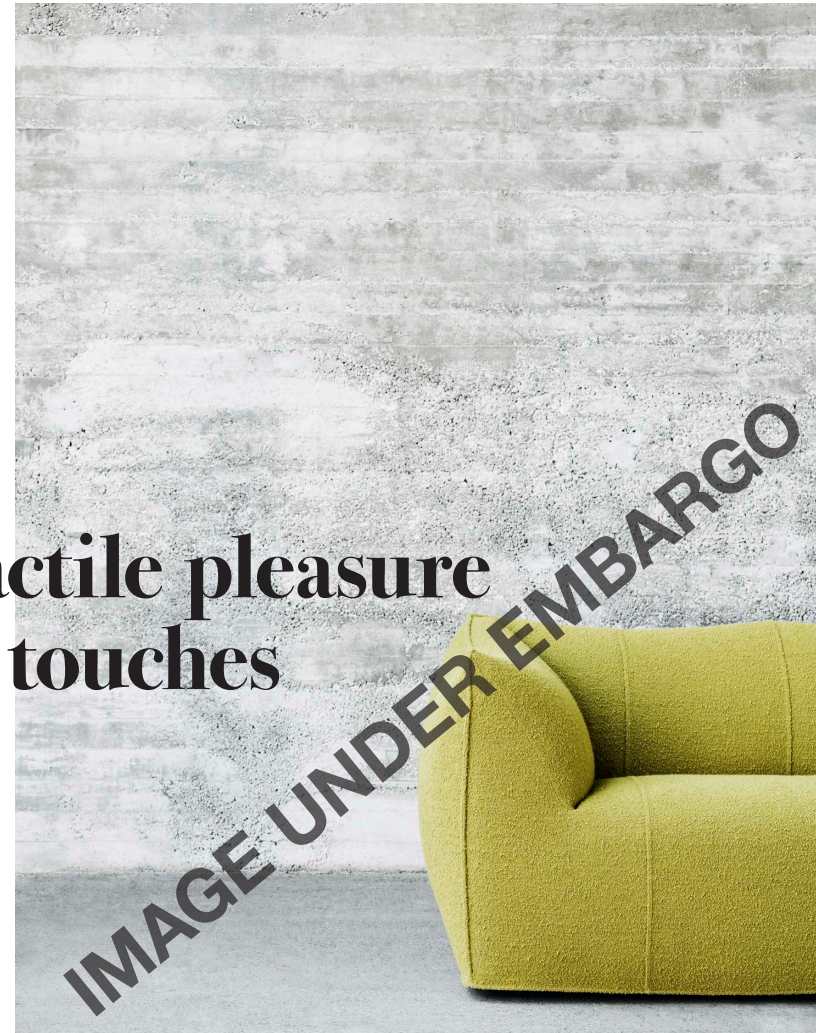

Sila

Sila, is the new sablé fabric with a mixed fibers composition, available in eight colours chosen by Mario Bellini. Its pleasingly irregular, three-dimensional nature amplifies the effect of softness through a studied irregularity that seems reminiscent of natural, spontaneous surfaces. This sensation begins with sight and is completed by touch.



Sila

Composition
ACRYLIC 56%
POLYESTER 15%
VISCOSE 12%
COTTON 11%
LINEN 6%

Fabric flame resistance
BS 5852 - 0&1
TB 117 - 2013



SILA 100



SILA 280

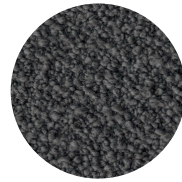

SILA 257

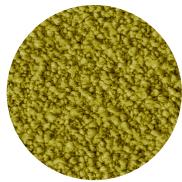

SILA 445

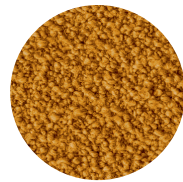

SILA 550

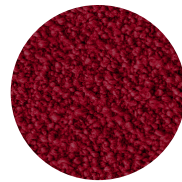

SILA 752

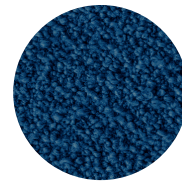

SILA 801

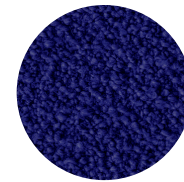

SILA 650



FABRIC SCALE AT 100%

Manila

An important new addition is the Manila fabric, strongly desired by the designer: a dreamy and humorous floral print featuring large roses with the classical feel of the 1972 cover but with renewed colors and patterns.

An unusual contrast capable of giving each Bambola a totally unexpected look. This limited edition fabric will be available on a white or black base.

The version of the Bambola armchair in Manila fabric can be ordered exclusively through the Direct to Consumer channels (e-Commerce, Monobrand and Flagship Stores).



Manila

Composition

MERINO WOOL 42%

COTTON 25%

MODAL 25%

POLYAMIDE 8%

Fabric flame resistance

BS 5852 - 0&1

TB 117 - 2013



MANILA 783



MANILA 580

Layout proposals



Window proposals

01



02



Layout proposals



Layout proposals

Granbambola LBA3
Sila 280
Back cushion 65x55 Sila 550



Bibambola LBA2
Sila 550



Spool TSP40
Glossy tobacco 4232L



Mera MTR90 - MTR60 - MTR39B
Natural Carrara white "venatino statuarietto"
marble 0900M, bronzed nickel painted 0174B



Husk H2G
Sidro 371, white shell 0010B,
brushed light oak 0374C



Riso RS4T
Soil 0071G



Layout proposals



Layout proposals

DA

Surface CSF75VM
Brushed light oak 0374C,
section: glossy dove grey 3738L,
bronzed nickel painted 0174B



Bamboletto LBL180
Sila 801



Bambola LBA1
Koto 280



Spool TSP40
Glossy dove grey 3738L



Cozy TCZ68_V
Brushed light oak 0374C,
pewter painted 0259V



Surface CSF120BV
Brushed light oak 0374C,
section: glossy dove grey 3738L,
bronzed nickel painted 0174B



Milos ML4T
Quartz 0134Q

Layout proposals

