

— Solids
B&B Italia
2023

18th - 23rd April

B&B
ITALIA



—Solids
B&B Italia
2023
Index

- Concept**
- New products**
- New textiles**
- Range extensions**
- Layout proposals**
- Marketing & Communication**
- Event Plan & Info**

— Solids
B&B Italia
2023
Concept



“We wanted to respect B&B Italia’s creative DNA and its multiple languages, a tribute to its ability to keep paradoxes under control. B&B Italia is recognised for great classics but at the same time has always been able to surprise. This year we wanted to be as surprising as possible.”

—Piero Lissoni, Artistic Director at B&B Italia

— Solids
B&B Italia
2023
Products



**—New
Products
2023**

Dambo Sofa System
design Piero Lissoni

Eryt Armchair
design Piero Lissoni

Tortello Sofa and Armchair
design Edward Barber & Jay Osgerby

Quiet Lines Complements
design Gabriel Tan

Lemante Small tables
design Kensaku Oshiro

Flair O' Couture Chair
design Monica Armani

Heri O' Chair
design Monica Armani

Tetrami Storage Units
design Naoto Fukasawa

**—New
textiles
2023**

Lagos
Lissy
Liam
Milo

**—Range
Extensions**

Allure O' Table
design Monica Armani

Tobi-Ishi Table
design Barber & Osgerby

Alys 10 Bed
design Gabriele & Oscar Buratti

Serie UP
Compasso d'Oro
design Gaetano Pesce

— Dambo Sofa System

design Piero Lissoni

— Dambo

Sofa System

design Piero Lissoni

[back to Products index](#)

[back to Dambo chapter beginning](#)

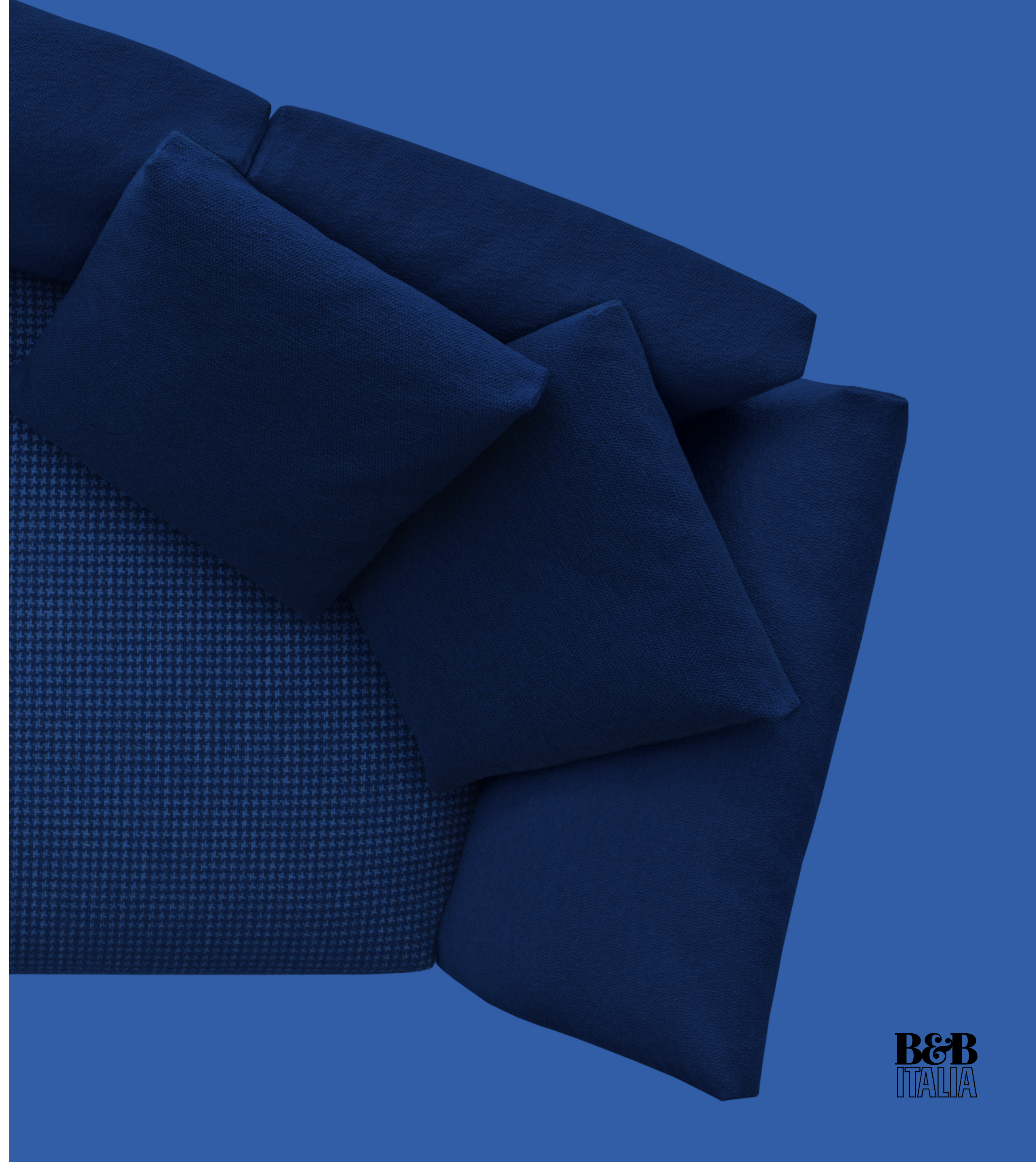

B&B
ITALIA



—Dambo, design Piero Lissoni

“Dambo is a modular system that suggests a new way of sitting, a system of large islands. The sofa is assembled in a simple way and features an armrest with an asymmetrical movement. I imagined it as an island amid the ebb and flow of everyday life. An island to enjoy alone or in company, to listen to music, to read and, why not, even to sit at the computer. It is very technological, we have cleaned it of everything that is not needed, it can be completely disassembled, and we have also added a few surprises in the construction of the cushions, which of course I cannot reveal to you. The beautiful thing is its presence, it can create unexpected places but at the same time much more classical, less casual places.”

— Piero Lissoni

-Dambo Sofa System

design Piero Lissoni

5 elements
28 item codes

Linear modules

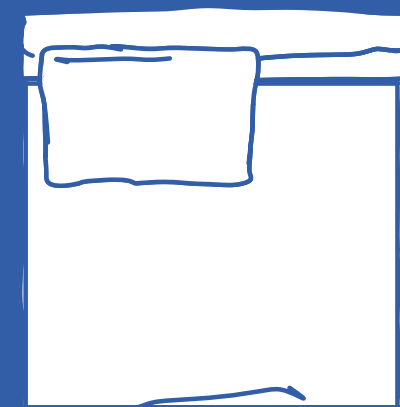

single

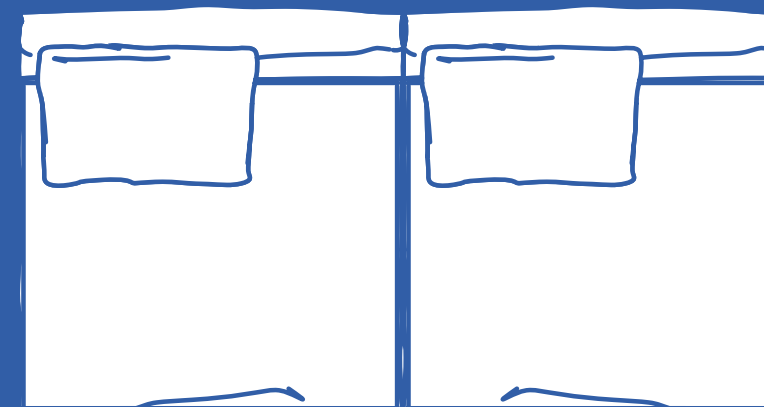

double

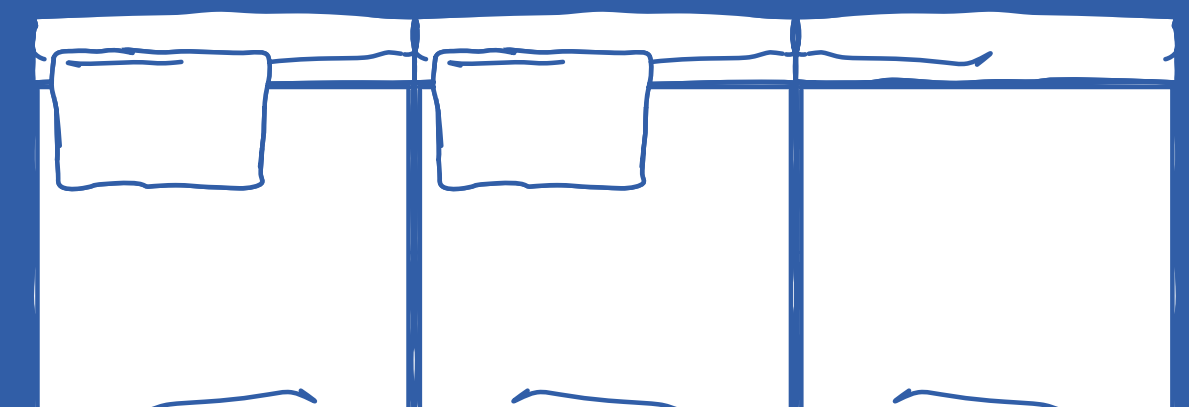

triple

Curved modules

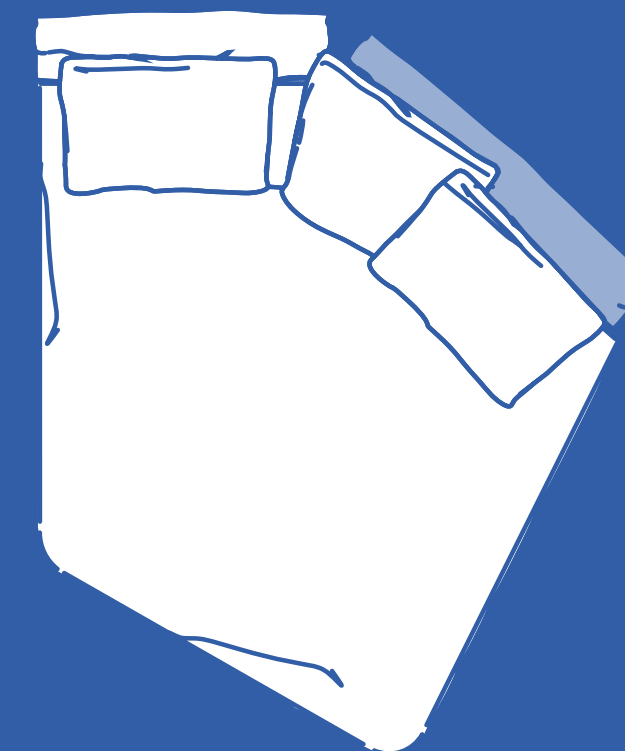
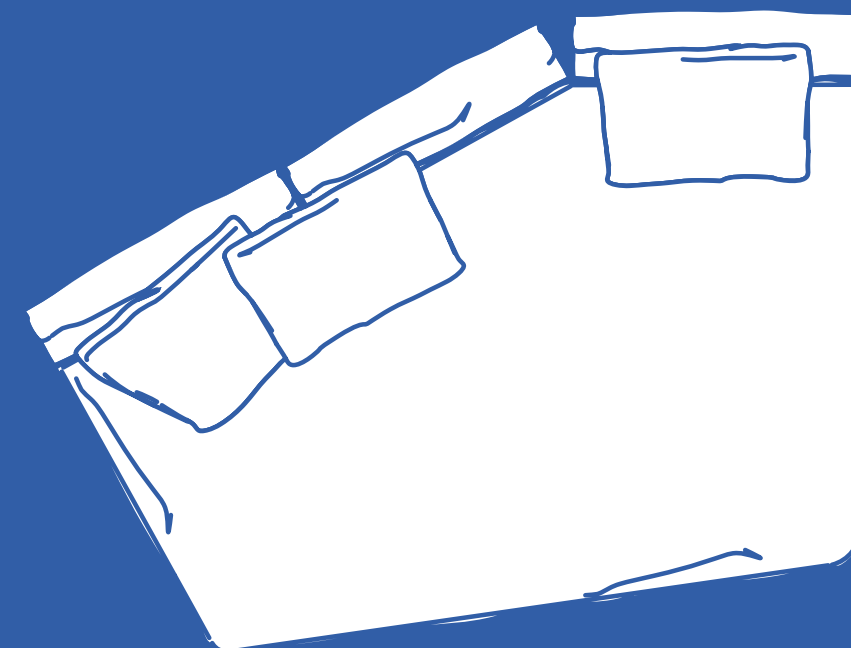

-Dambo Sofa System

design Piero Lissoni

28 item codes
Multiple configurations

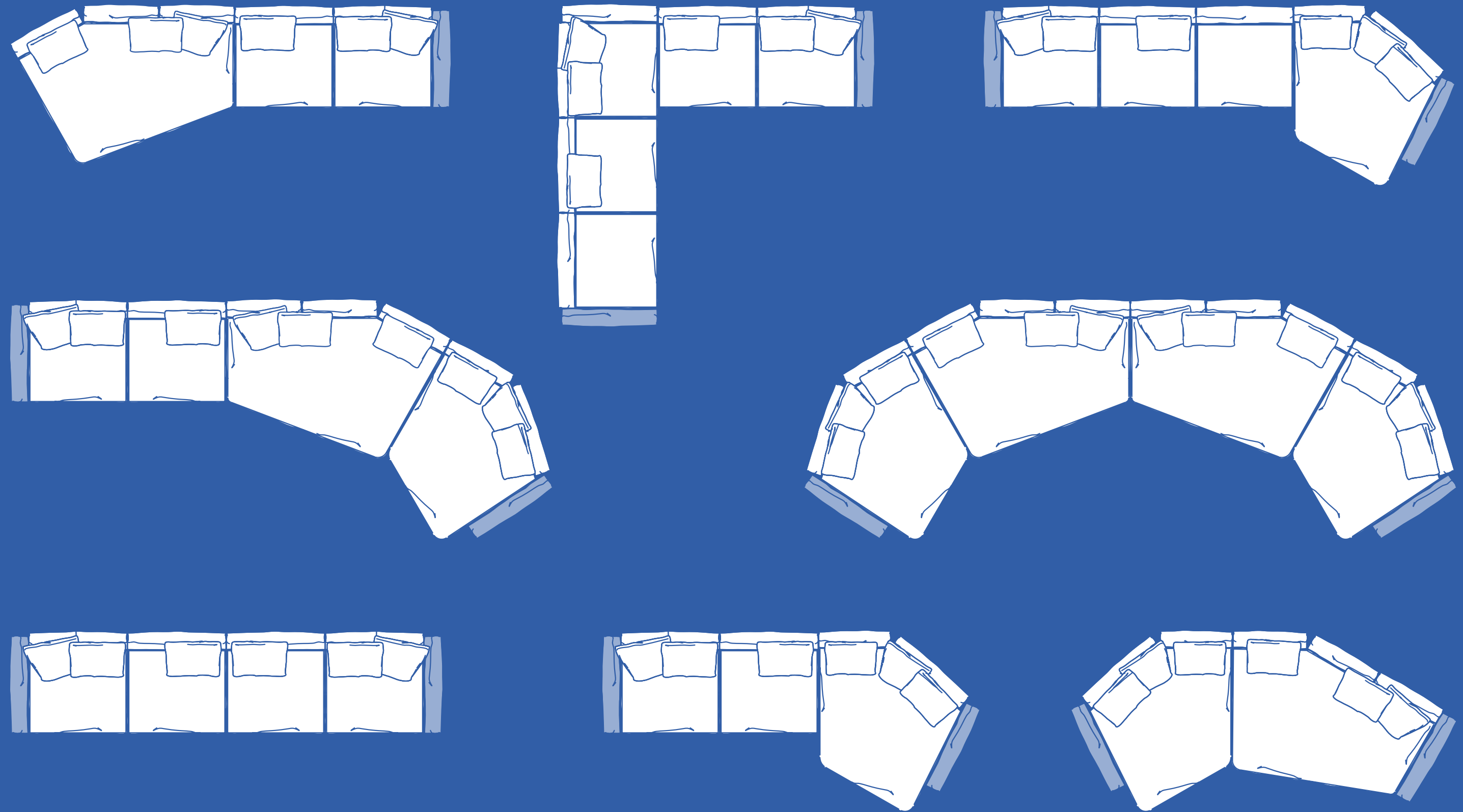



Dambo is the third sofa system that Piero Lissoni has designed for B&B Italia. It's a modular system composed of irregular pentagons and rectangular modules that combines more complex geometric shapes with linear elements and lends itself to multiple compositions and environments.

The pentagonal base elements, with their large dimensions and great flexibility, can be used as peninsulas when combined with other elements or as free-standing monoliths. They are cosy volumes to be placed in the middle of a room, to craft corner solutions or to create

customized compositions. For a more eclectic living room, they can also dialogue with previous collections to create an actual archipelago of combinations, where the uniqueness of each element contributes to telling a heterogeneous yet coherent story.

The high, enveloping backrests are a hymn to the organic forms of the botanical world. The armrests resemble petals thanks to a front movement that allows them to be lowered and adjusted as desired. There are five basic elements, characterised by a cosy softness and plush ergonomics.



The different geometries are in harmony with each other, informal yet functional and versatile. The entire series boasts a cold-foamed construction system with state-of-the-art upholstery. Backrests and armrests are attached to the base structure by means of a bayonet coupling system. The small feet, with their discrete and essential

design, have an elegant oval section. What emerges is lightness but also versatility, in line with the contemporary lifestyle dictates increasingly merging living spaces and home office corners. Dambo thus lends itself to a wide audience, faithful to the B&B Italia tradition, but with an eye on the art of modern living.



—Dambo

Sofa System

design Piero Lissoni



[back to Products index](#)

[back to **Dambo** chapter beginning](#)

B&B
ITALIA

—Dambo Sofa System

design Piero Lissoni

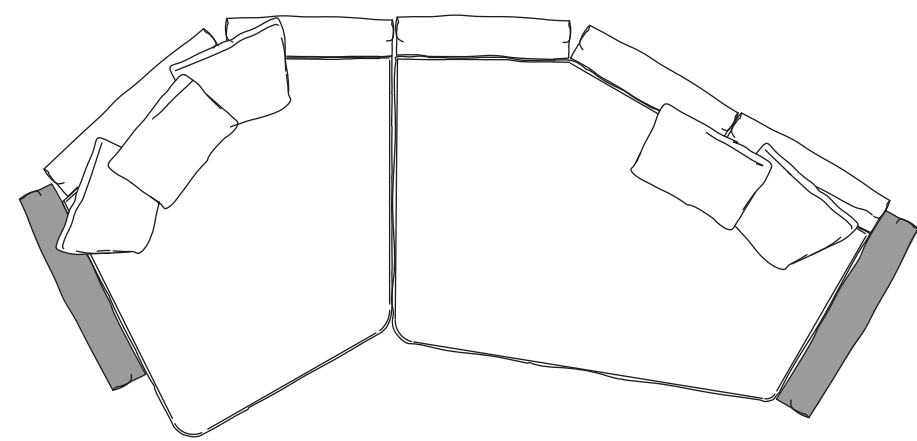

[back to Products index](#)

[back to Dambo chapter beginning](#)

B&B
ITALIA

—Dambo Sofa System

design Piero Lissoni

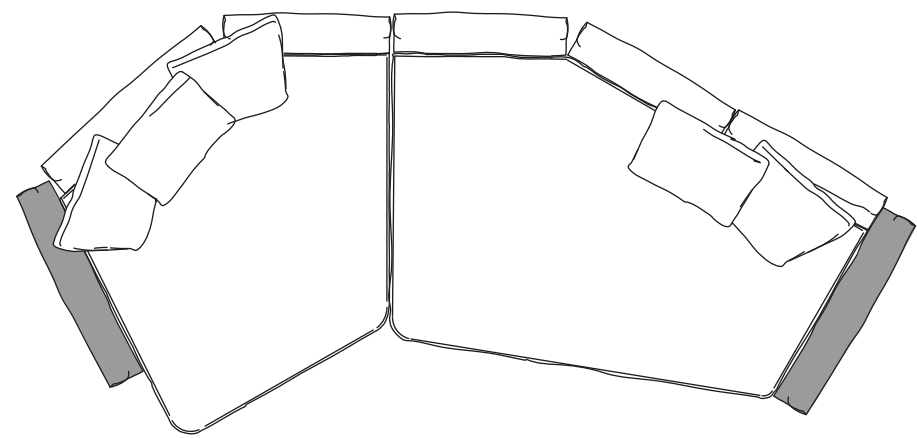

[back to Products index](#)

[back to Dambo chapter beginning](#)

B&B
ITALIA

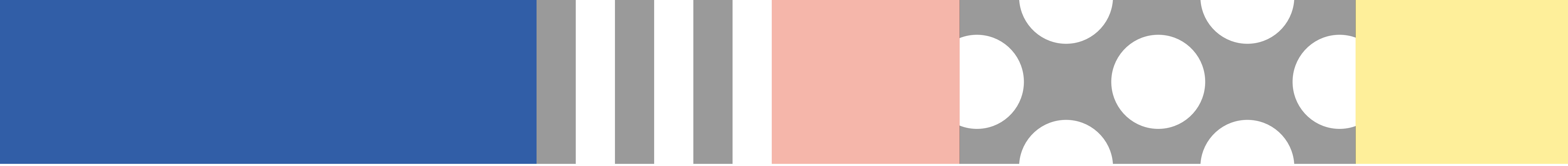

—Dambo

Sofa System

design Piero Lissoni



[back to Products index](#)

[back to Dambo chapter beginning](#)

B&B
ITALIA

—Dambo

Sofa System

design Piero Lissoni

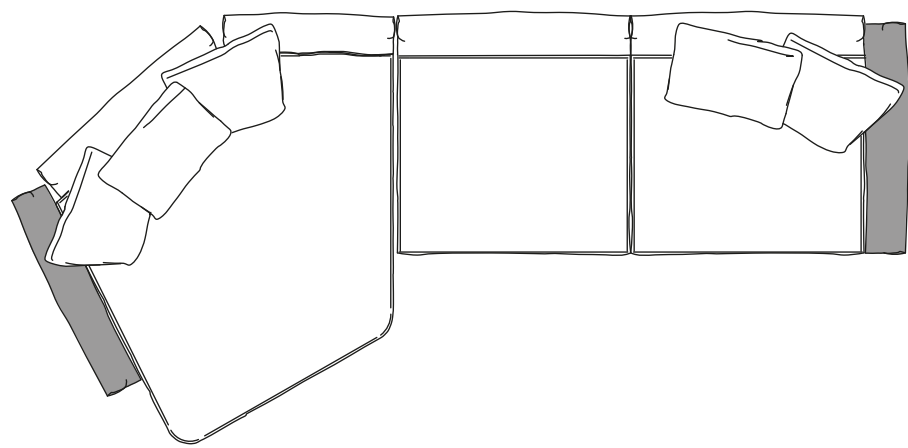

—Dambo

Sofa System

design Piero Lissoni

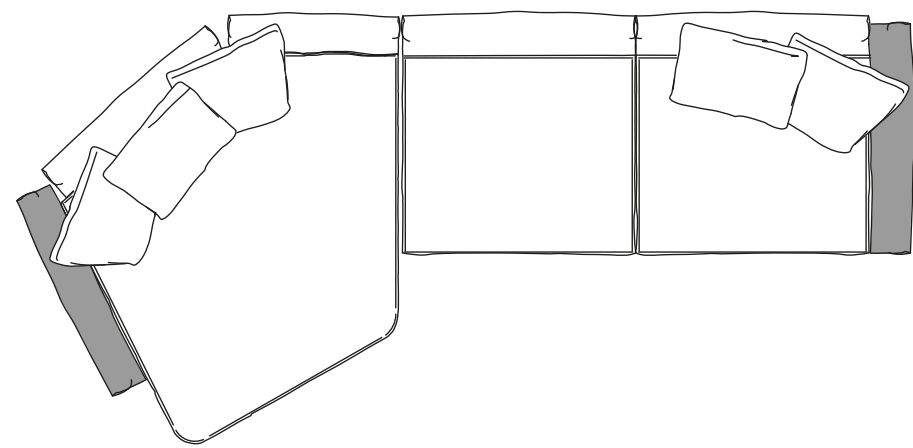

[back to Products index](#)

[back to Dambo chapter beginning](#)

B&B
ITALIA

—Dambo Sofa System

design Piero Lissoni

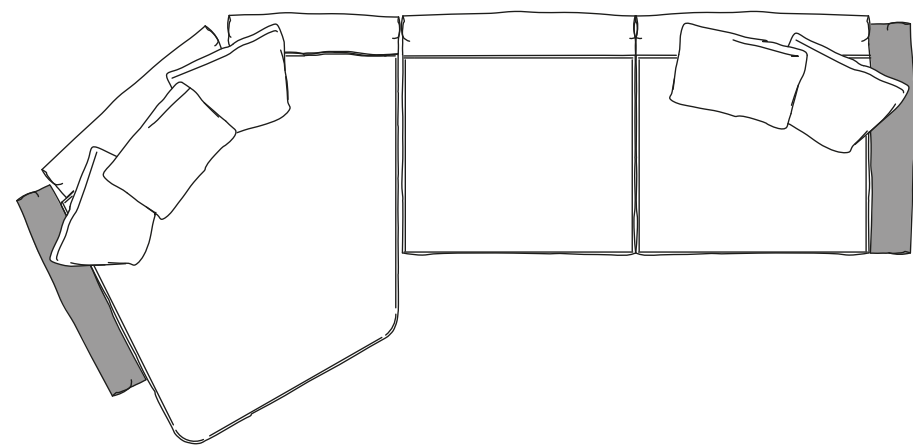

[back to Products index](#)

[back to Dambo chapter beginning](#)

B&B
ITALIA

—Dambo

Sofa System

design Piero Lissoni

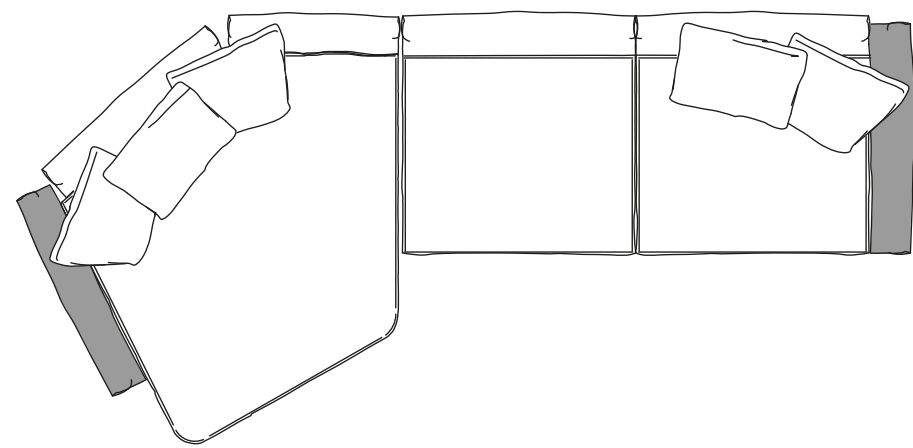

[back to Products index](#)

[back to Dambo chapter beginning](#)

B&B
ITALIA

—Dambo

Sofa System

design Piero Lissoni



[back to Products index](#)

[back to **Dambo** chapter beginning](#)

B&B
ITALIA

—Dambo Sofa System

design Piero Lissoni

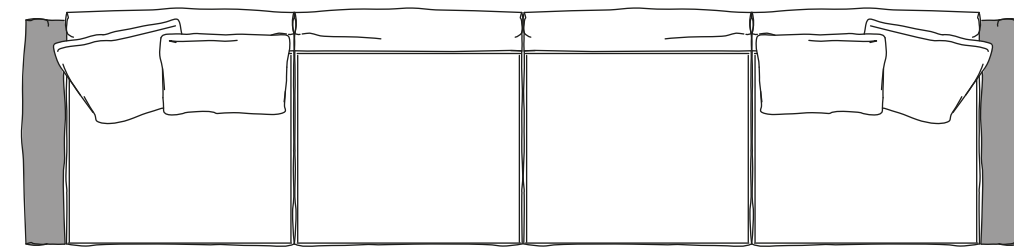

—Dambo Sofa System

design Piero Lissoni

DM218

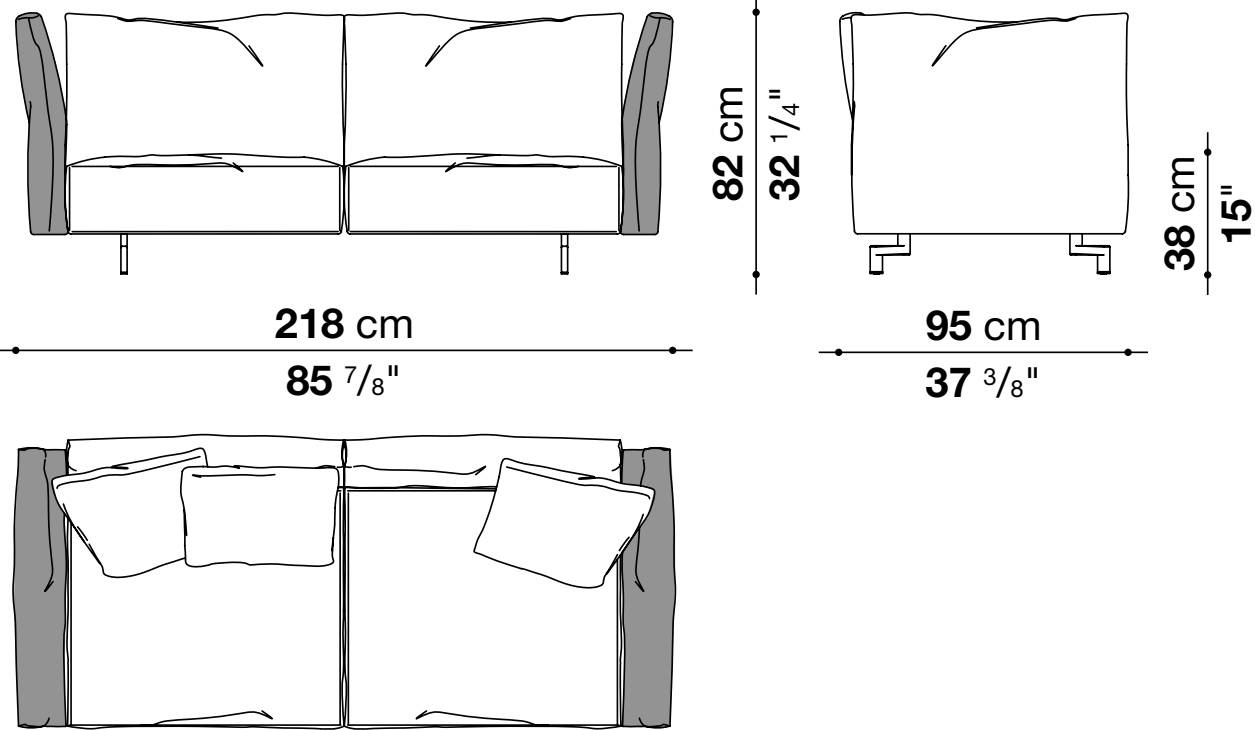

DM312

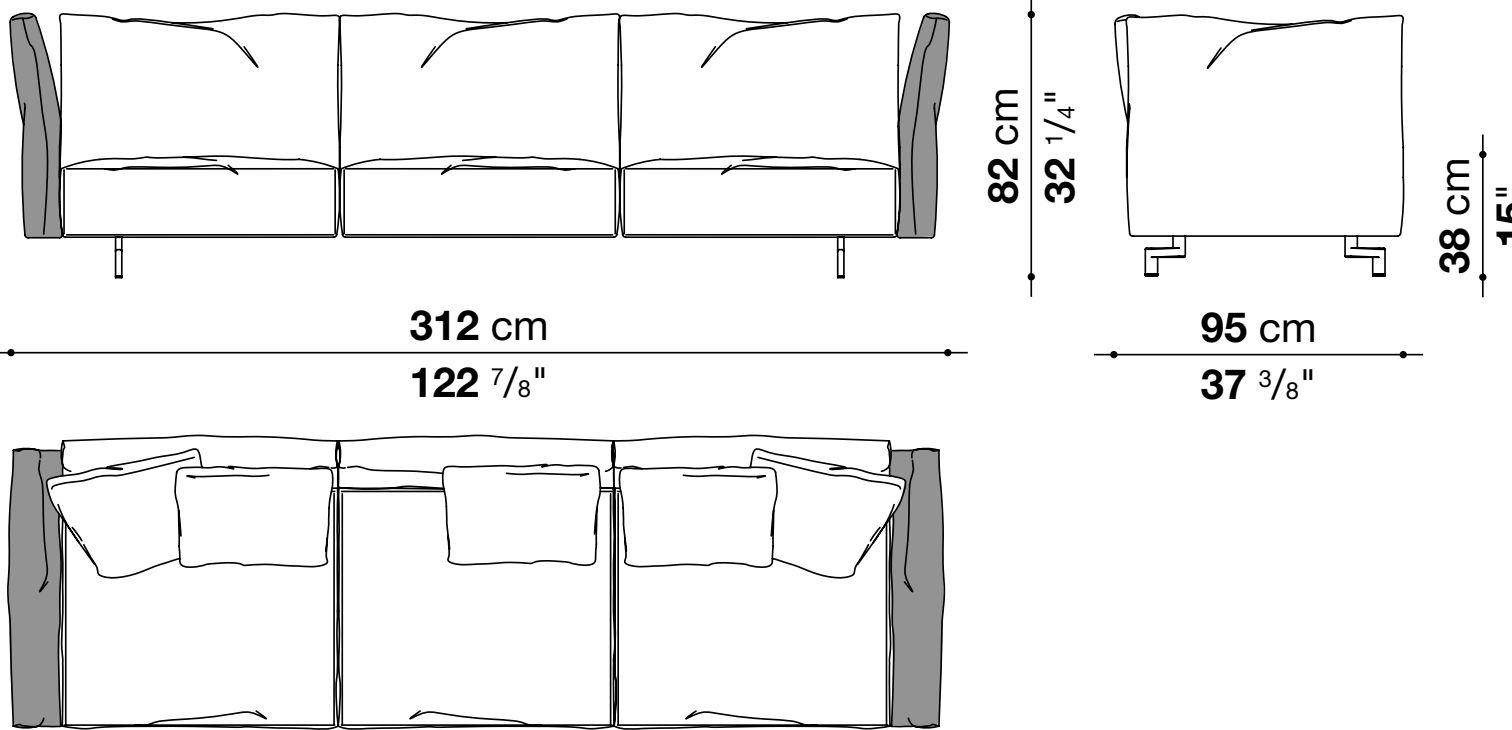

—Dambo Sofa System

design Piero Lissoni

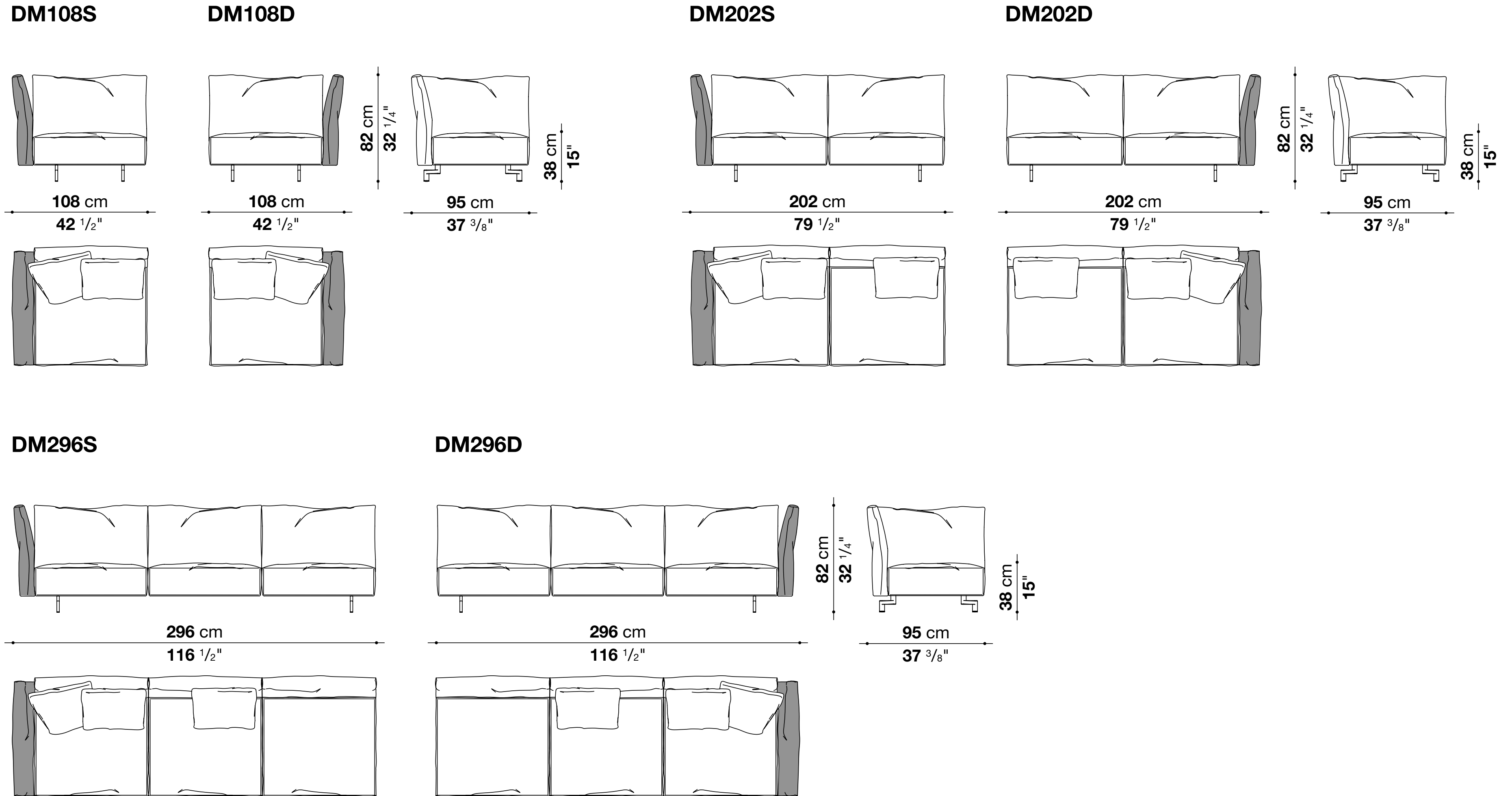

—Dambo Sofa System

design Piero Lissoni

DM108AS

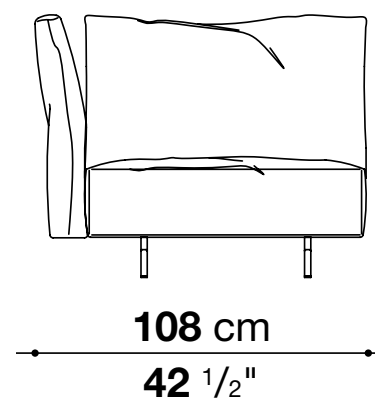

108 cm
42 1/2"

DM108AD

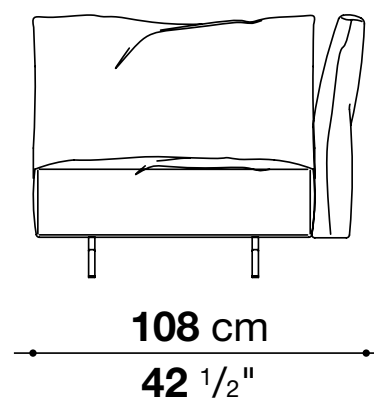

108 cm
42 1/2"

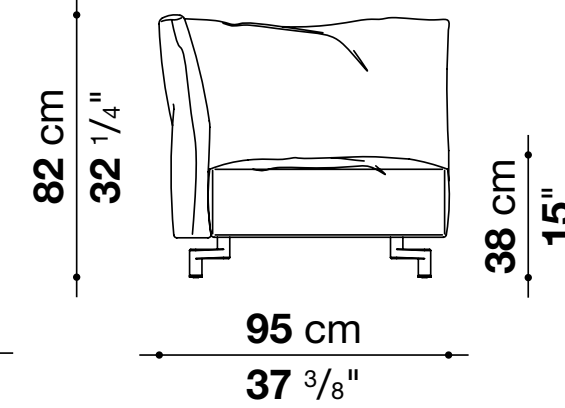

95 cm
37 3/8"

DM218AS

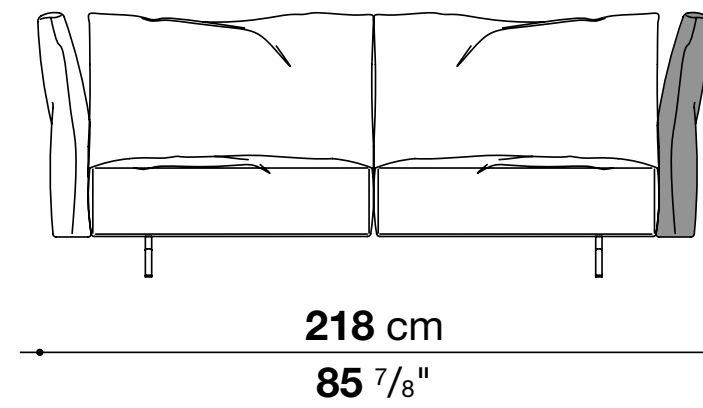

218 cm
85 7/8"

DM218AD

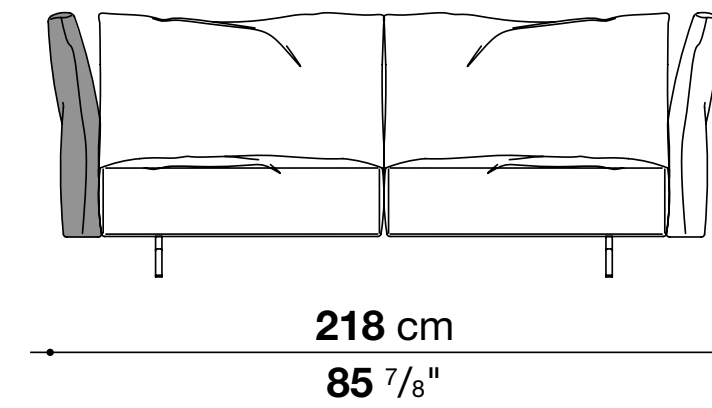

218 cm
85 7/8"

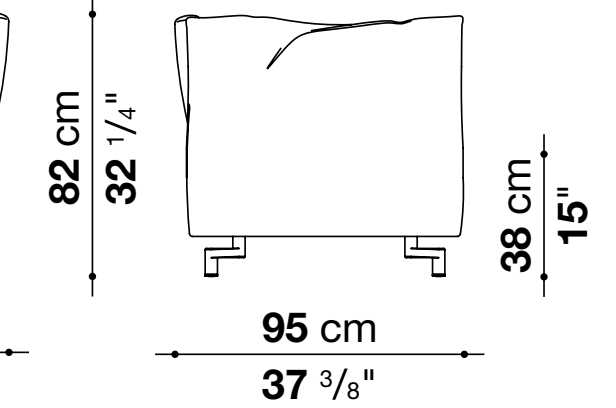

95 cm
37 3/8"

DM312AS

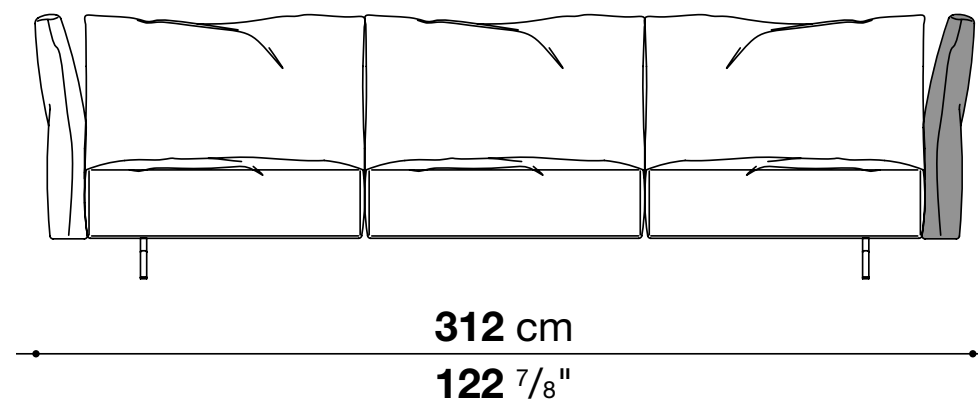

312 cm
122 7/8"

DM312AD

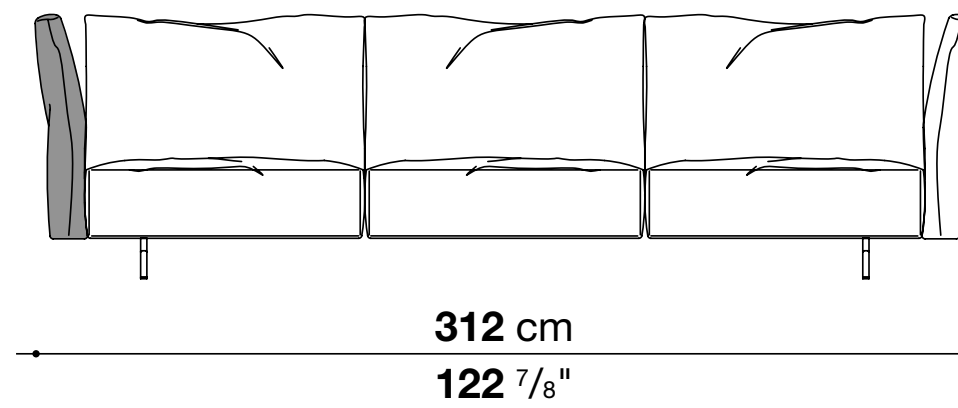

312 cm
122 7/8"

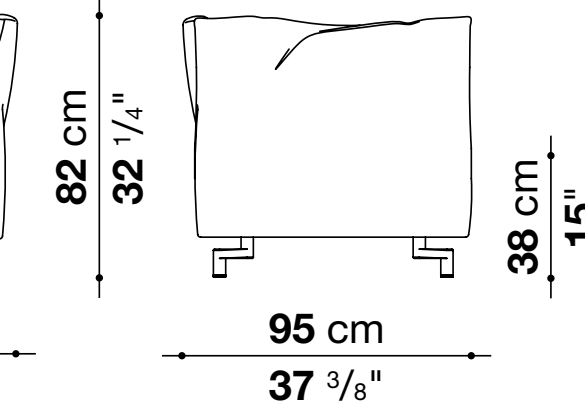

95 cm
37 3/8"

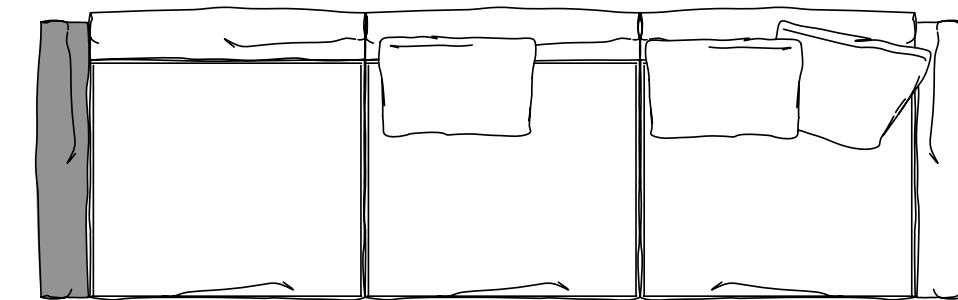
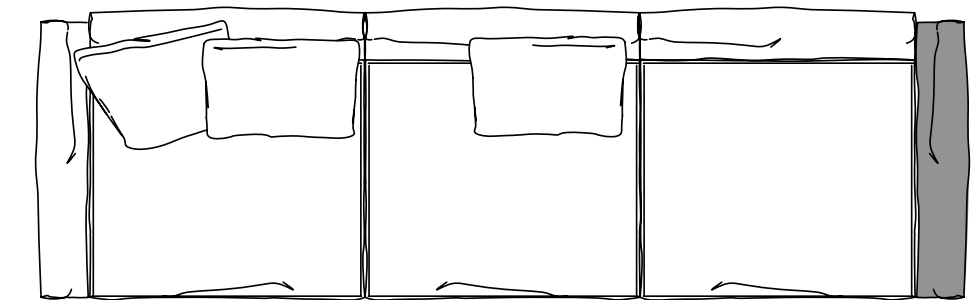

—Dambo Sofa System

design Piero Lissoni

DM92C

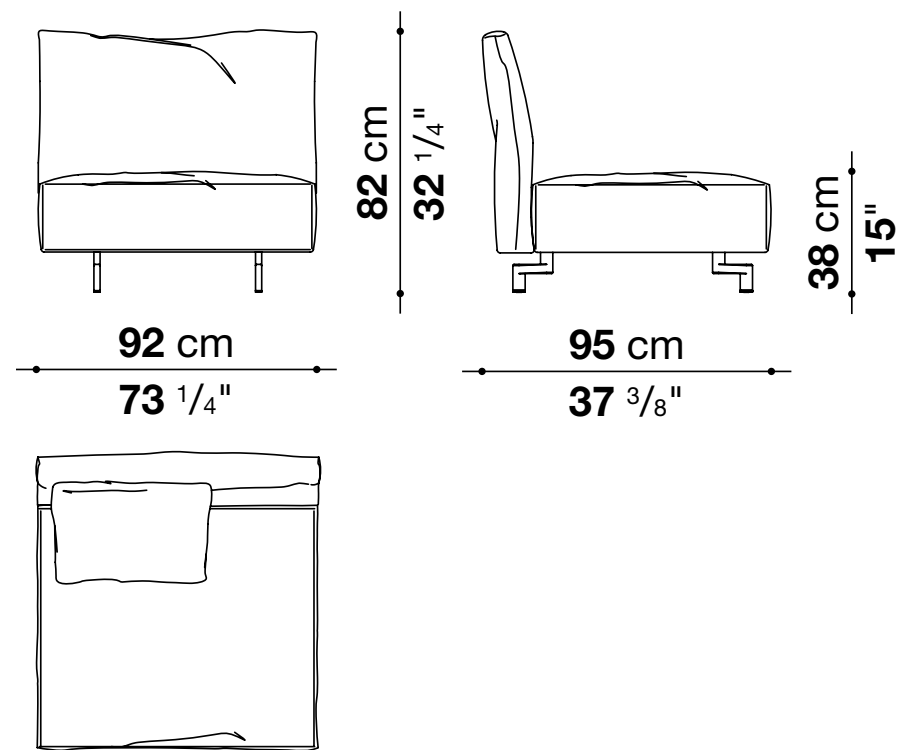

DM186C

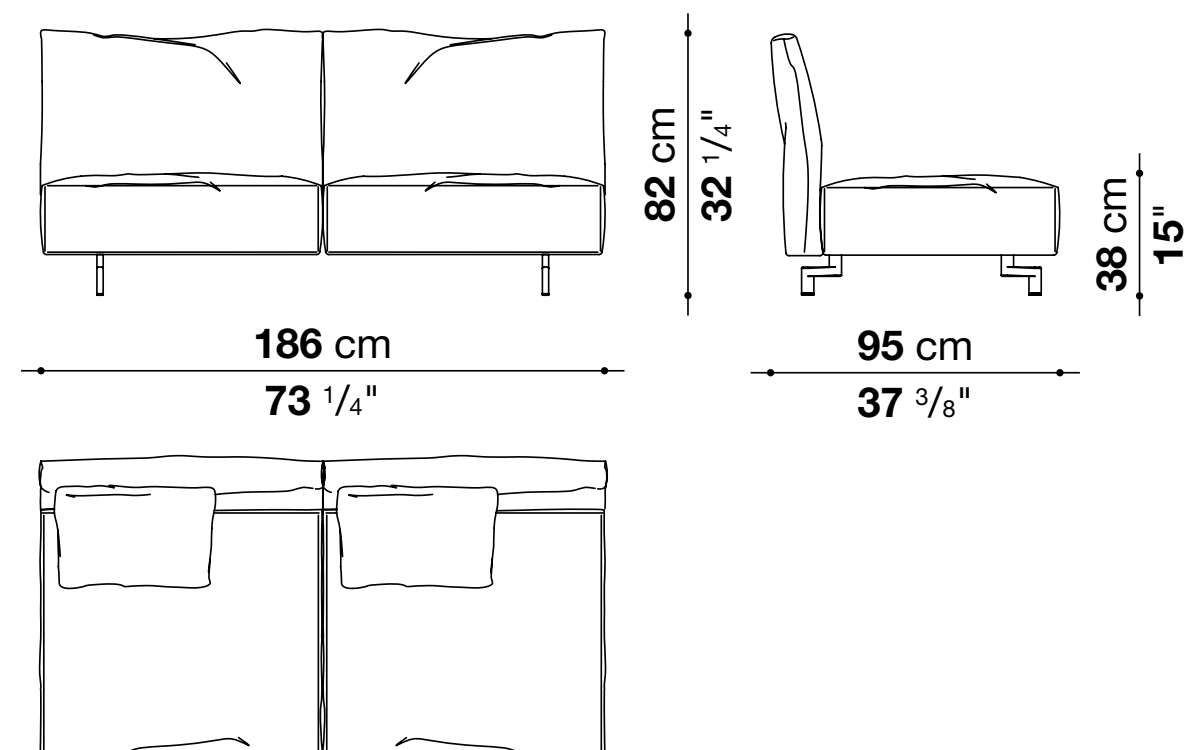

DM280C

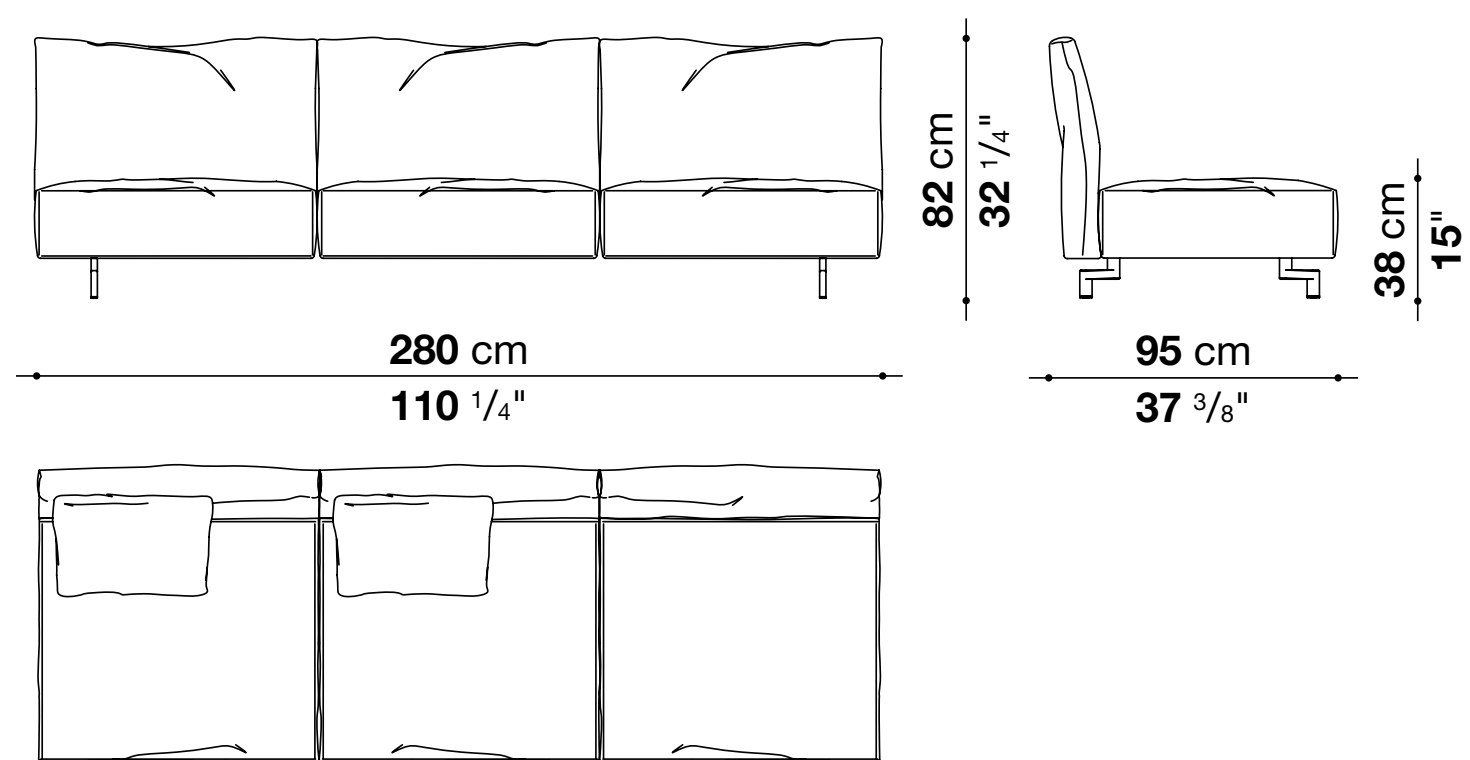

—Dambo

Sofa System

design Piero Lissoni

DM92P

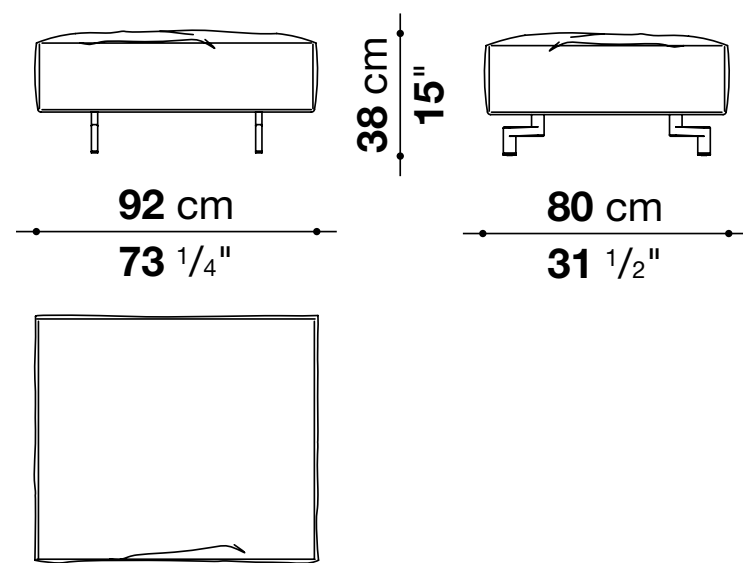

DM186P

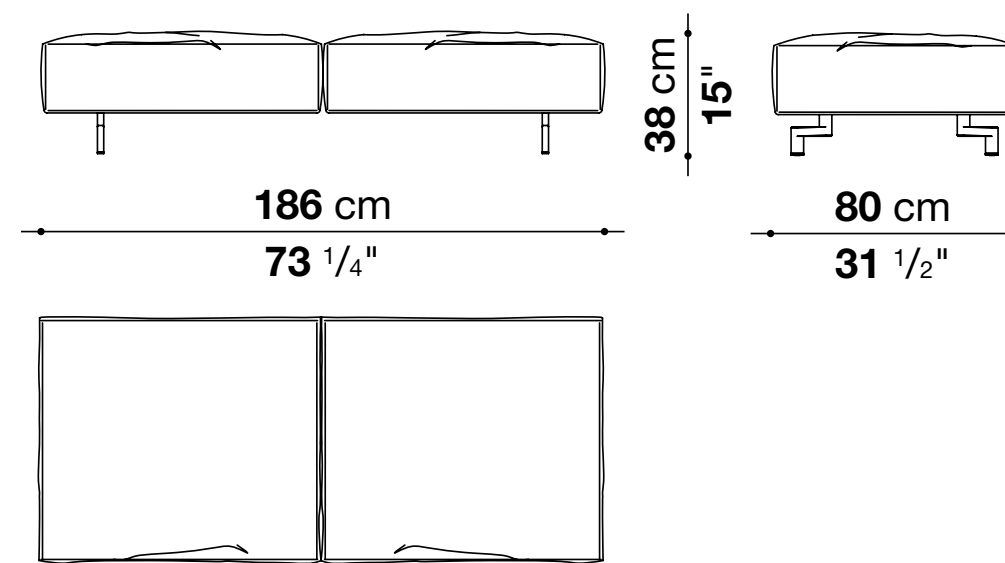

DM280P

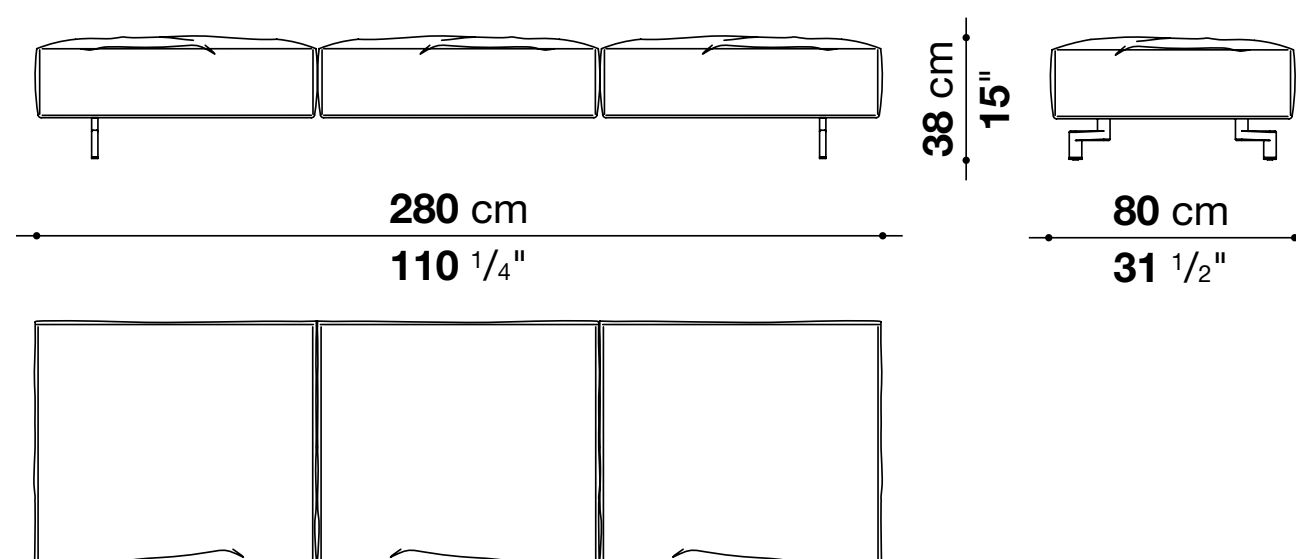

—Dambo

Sofa System

design Piero Lissoni

DM154LD_1 / DM154LS_1 (mirror version)

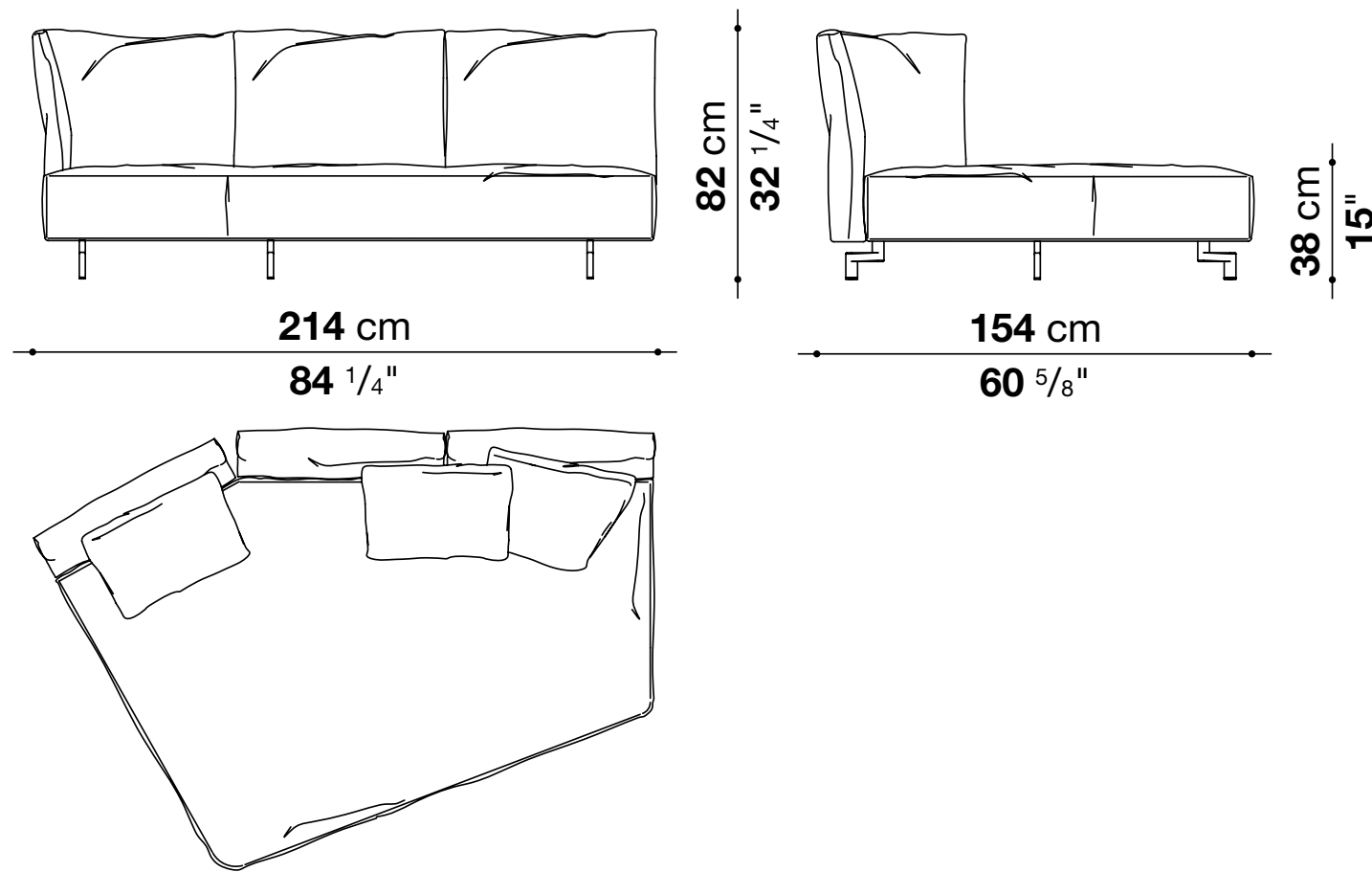

DM178LD_1 / DM178LS_1 (mirror version)

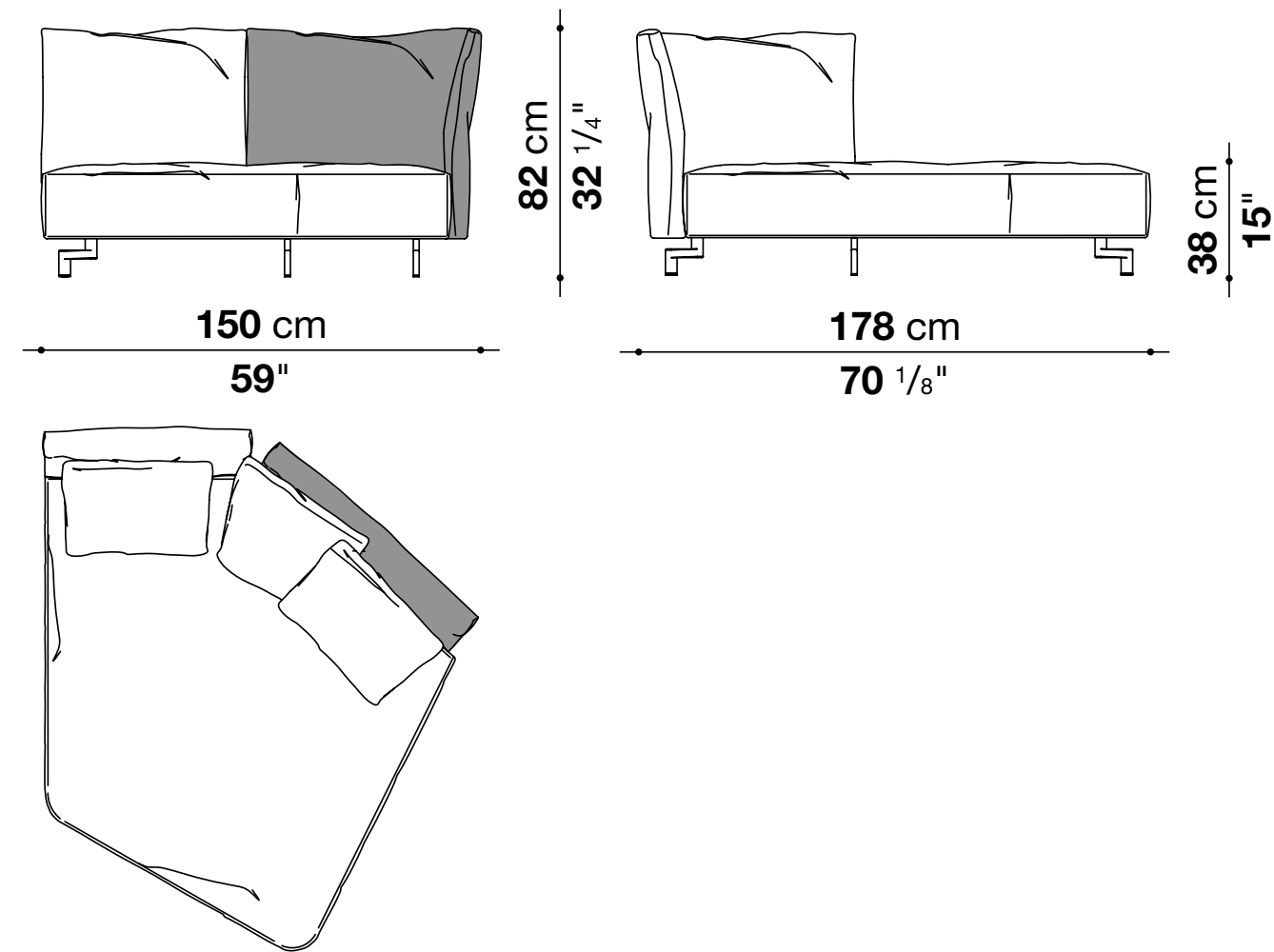

DM154LD_2 / DM154LS_2 (mirror version)

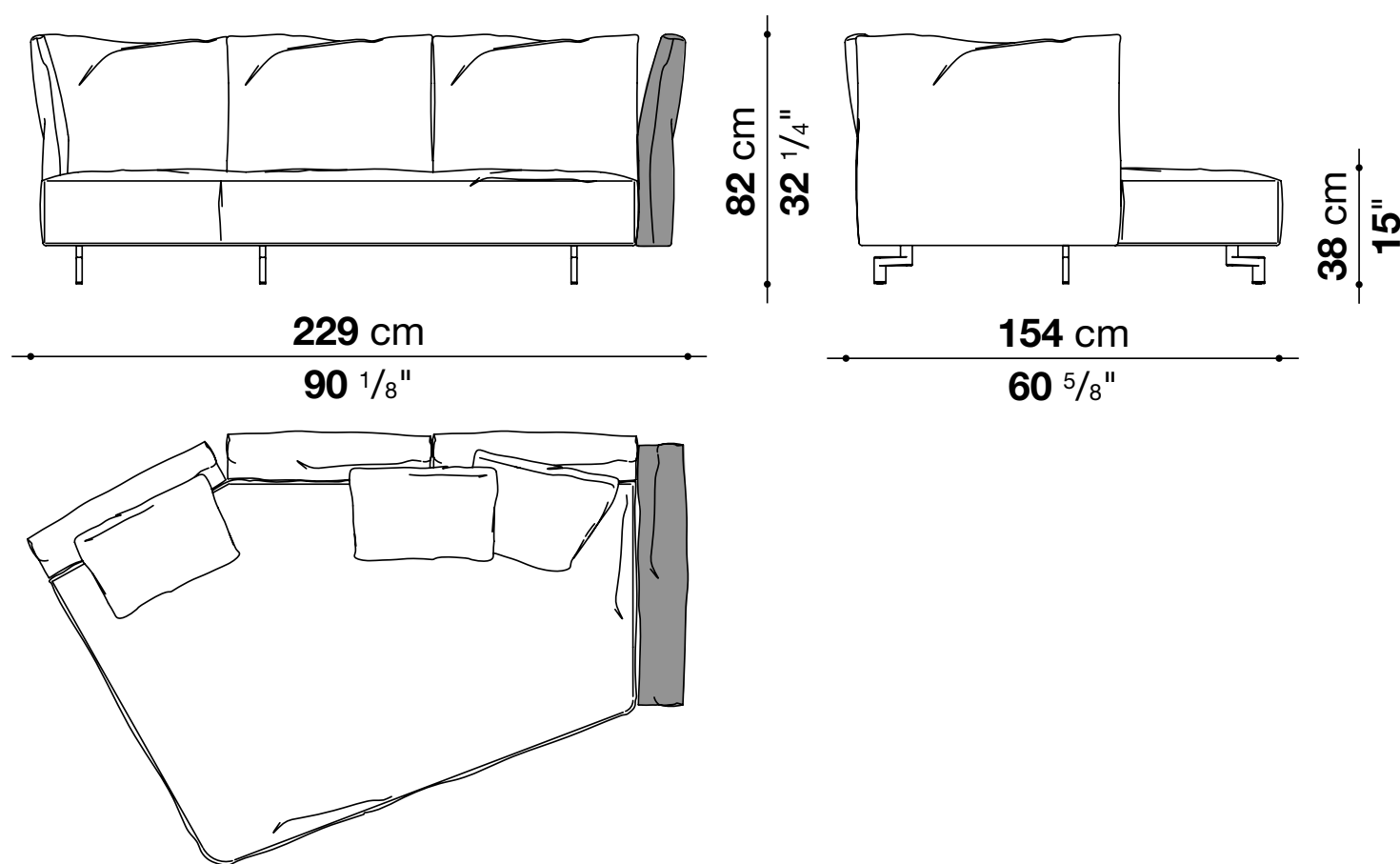

DM178LD_2 / DM178LS_2 (mirror version)

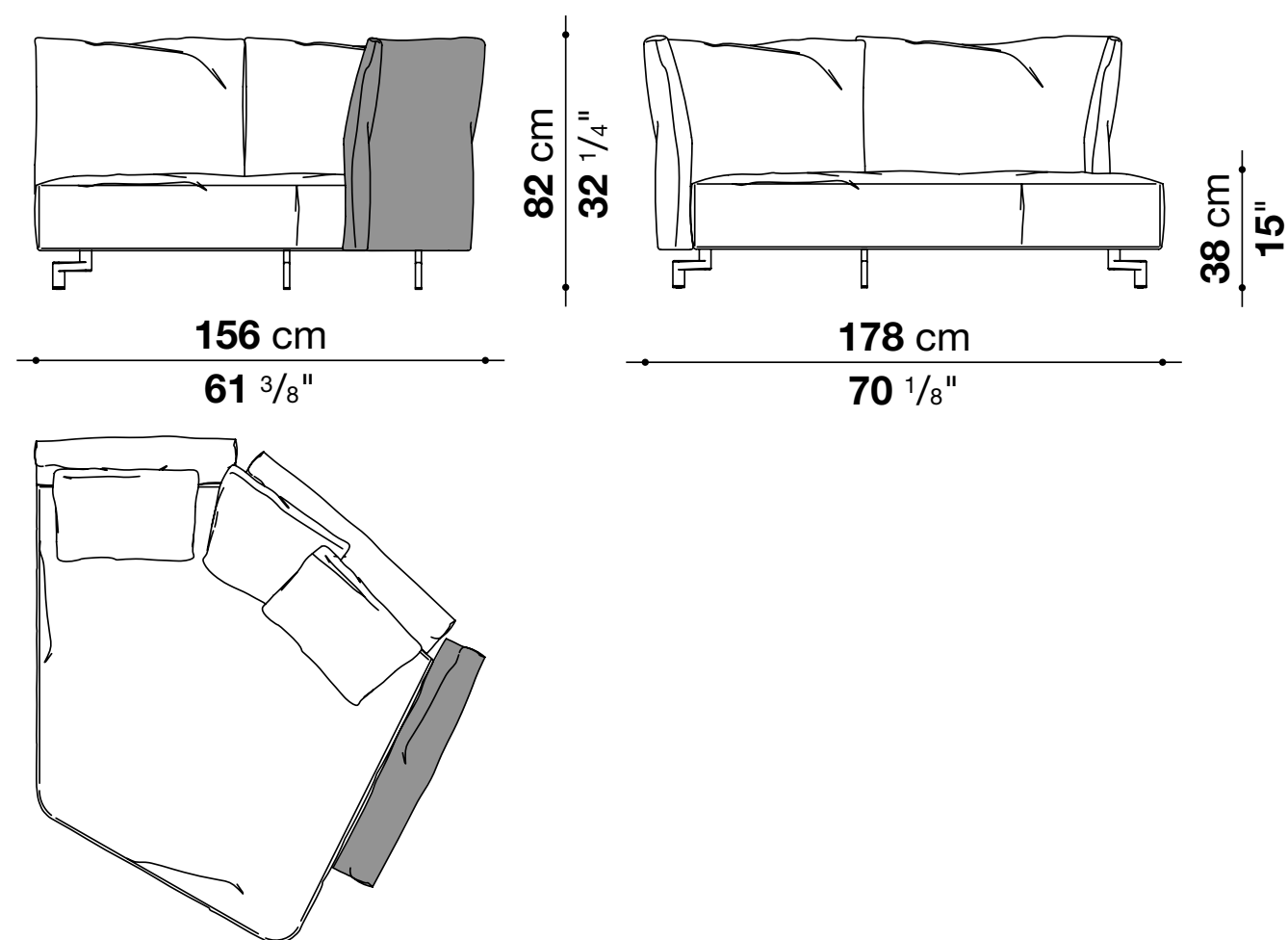

—Dambo Sofa System

design Piero Lissoni

COVER

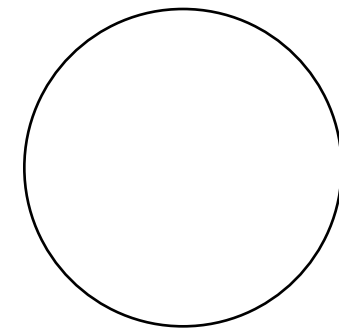

fabric

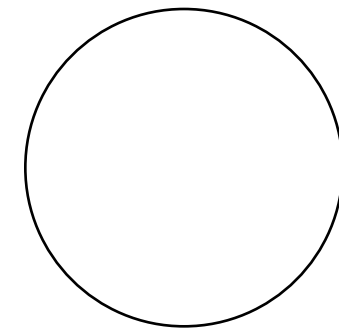

leather

FEET

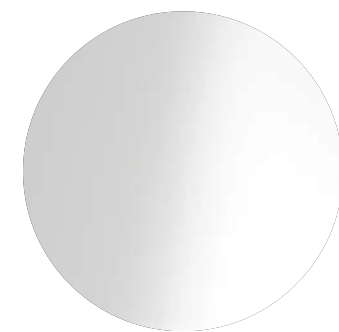

0189A
bright brushed
aluminium

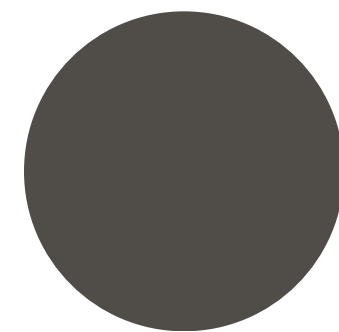

0174B
bronzed nickel
painted

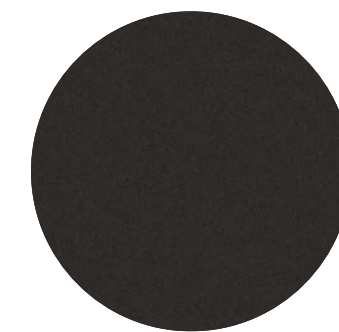

0170M
painted black
chromed

—Eryt Armchair

design Piero Lissoni

—Eryt Armchair

design Piero Lissoni

[back to Products index](#)

[back to Eryt chapter beginning](#)

B&B
ITALIA





—Eryt, design Piero Lissoni

“Eryt is a project I have wanted to do for many years with B&B Italia. I think it has a good expressiveness; at its core there is an idea of simplicity and respect for qualities that are very humanised, and wood is exploited to maximise its possibilities. When you see Eryt you realise it comprises all my classic mistakes: it’s wide, it’s low, one must always adjust the position, but it has a nice presence. You could say it’s an armchair with personality.”

— Piero Lissoni



Nodding to 1950s Nordic design and to elements of Japanese culture, Eryt is the new armchair by Piero Lissoni. With a strong graphic and welcoming presence, the ash structure recalls Nordic rigour and an oriental spirit through a linear combination of materials but with refined touches. The turned solid wooden frame is made of light or black brushed ash topped with a curved plywood backrest and seat.

The armchair is available entirely in wood or with the seat covered in thick leather and can be complemented with a soft elliptical cushion upholstered in fabric or leather. Eryt's design is reduced to a minimum to meet technical requirements, guarantee a light-weight aesthetic, and provide comfort.

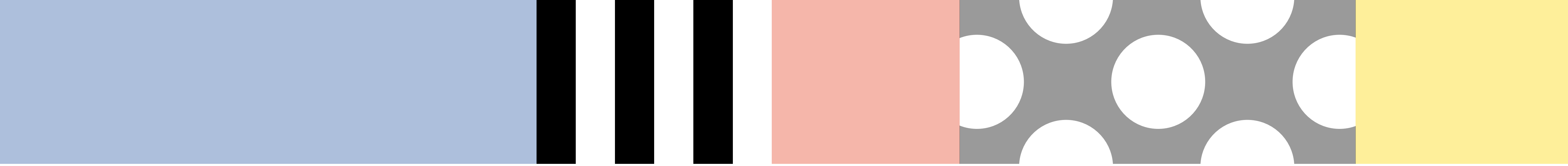

—Eryt Armchair

design Piero Lissoni



[back to Products index](#)

[back to Eryt chapter beginning](#)

—Eryt Armchair

design Piero Lissoni

ER78F

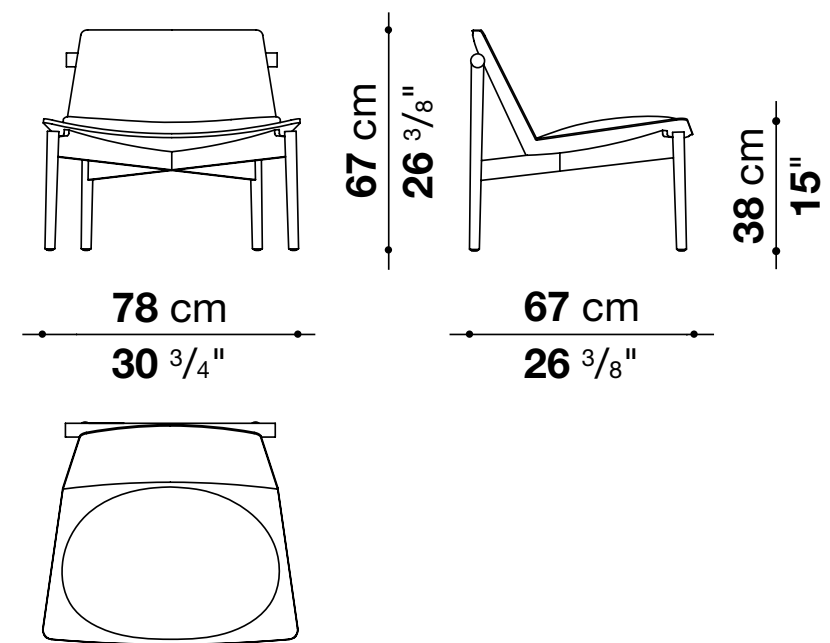

FRAME AND SEAT/BACK



0421C
brushed light ash

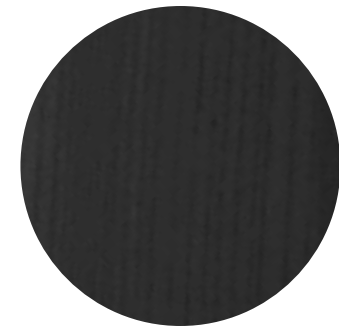

0494N
brushed black ash

SEAT CUSHION COVER

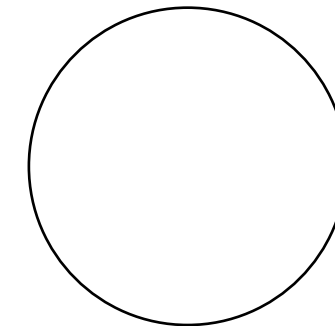

fabric

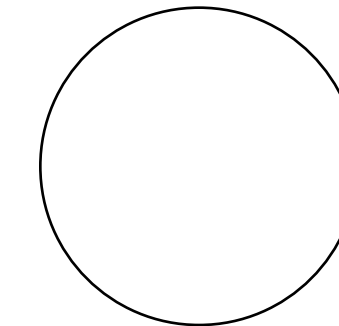

leather

SEAT/BACK COVER



1121104
milk white
thick leather

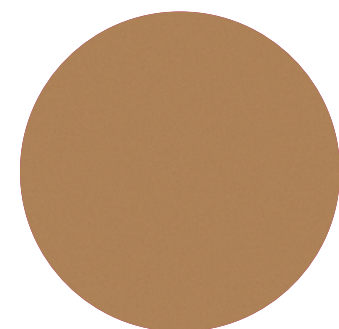

1121300
natural leather

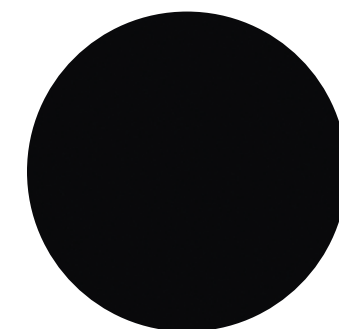

1121150
black thick leather

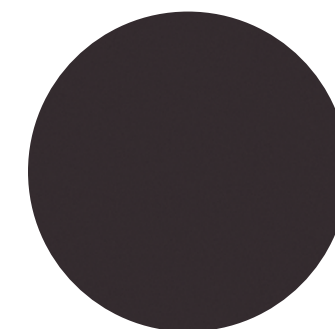

1121350
dark brown
thick leather

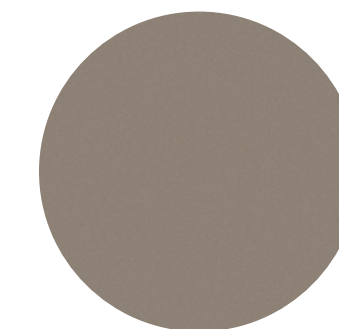

1121280
dove grey
thick leather

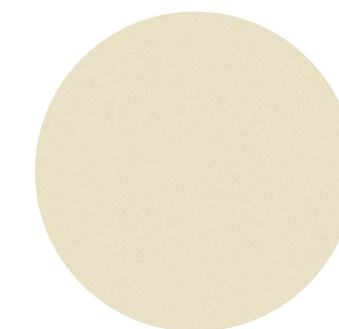

1121201
ivory thick leather

—Tortello Sofa and Armchair

design

Edward Barber & Jay Osgerby



—Tortello, design Edward Barber & Jay Osgerby

“Following on from our Tobi-Ishi family of tables, we have designed a new collection of upholstered seating. Sculptural in form, the Tortello sofa and armchair are generous in proportion and extremely soft, giving ultimate comfort. The informal shape offers different seating positions and makes Tortello a centrepiece.”

— Edward Barber & Jay Osgerby

—Tortello

Sofa and Armchair

design

Edward Barber & Jay Osgerby

[back to Products index](#)

[back to Tortello chapter beginning](#)



B&B
ITALIA



British designers Edward Barber and Jay Osgerby certainly know how to be witty, hinting at the name of their latest creation, Tortello. The new seat presents itself as a monolithic sofa and armchair that amuses with its generous, soft and cosy shapes. Just as the name leaves no room for the imagination, the design is also striking. Tortello is composed of several unexpected elements. The supporting structure, a sort of tray with a trapezoidal section base, is rotationally moulded from recycled polyethylene. It is then completed by an elastomer mattress on which

the foamed upper element is laid, a soft fabric-covered volume characterised by a peculiar profile thanks to a 'pinched' stitching. Tortello boasts responsible manufacturing thanks to the most advanced technologies and state-of-the-art materials. Circularity and recycling are at the heart of this new collection, starting with the structure in second-life polyethylene to which are added elements in polyurethane foam and thermoplastic elastomers that define its geometry and comfort.



Softness is guaranteed by a series of targeted constructive expedients, despite the fact that the quantity of polyurethane used is minimal. The choice of materials and construction techniques, which allow to

assemble the structural elements without the use of adhesive or glues, mean that Tortello can be completely disassembled and consequently easy to recycle.

—Tortello

Sofa and Armchair

design Barber & Osgerby



—Tortello

Sofa and Armchair

design Barber & Osgerby



[back to Products index](#)

[back to Tortello chapter beginning](#)

B&B
ITALIA

—Tortello

Sofa and Armchair

design Barber & Osgerby



[back to Products index](#)

[back to Tortello chapter beginning](#)

B&B
ITALIA

—Tortello

Sofa and Armchair

design Barber & Osgerby

Total absence of stickers

Traditional foam

POE Elastomer

Supporting structure in rotational molding from recycled polyethylene

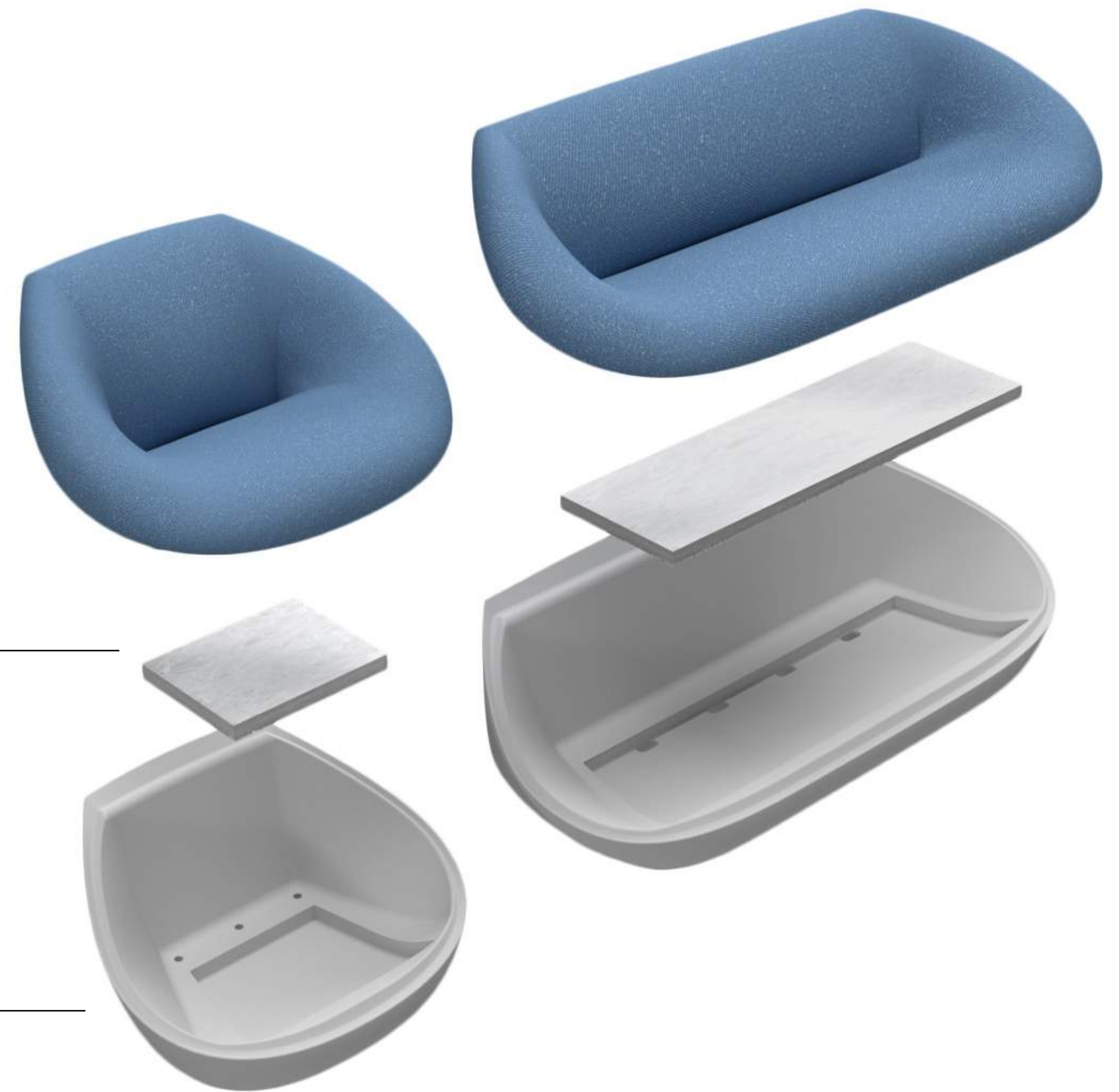
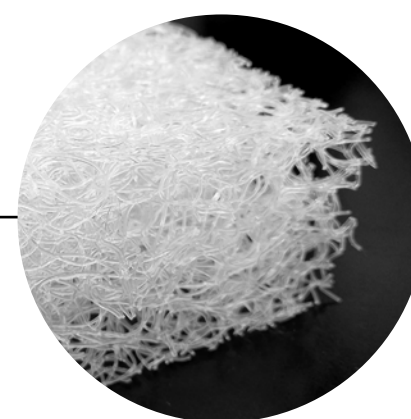

—Tortello Sofa and Armchair

design Barber & Osgerby

TRT250

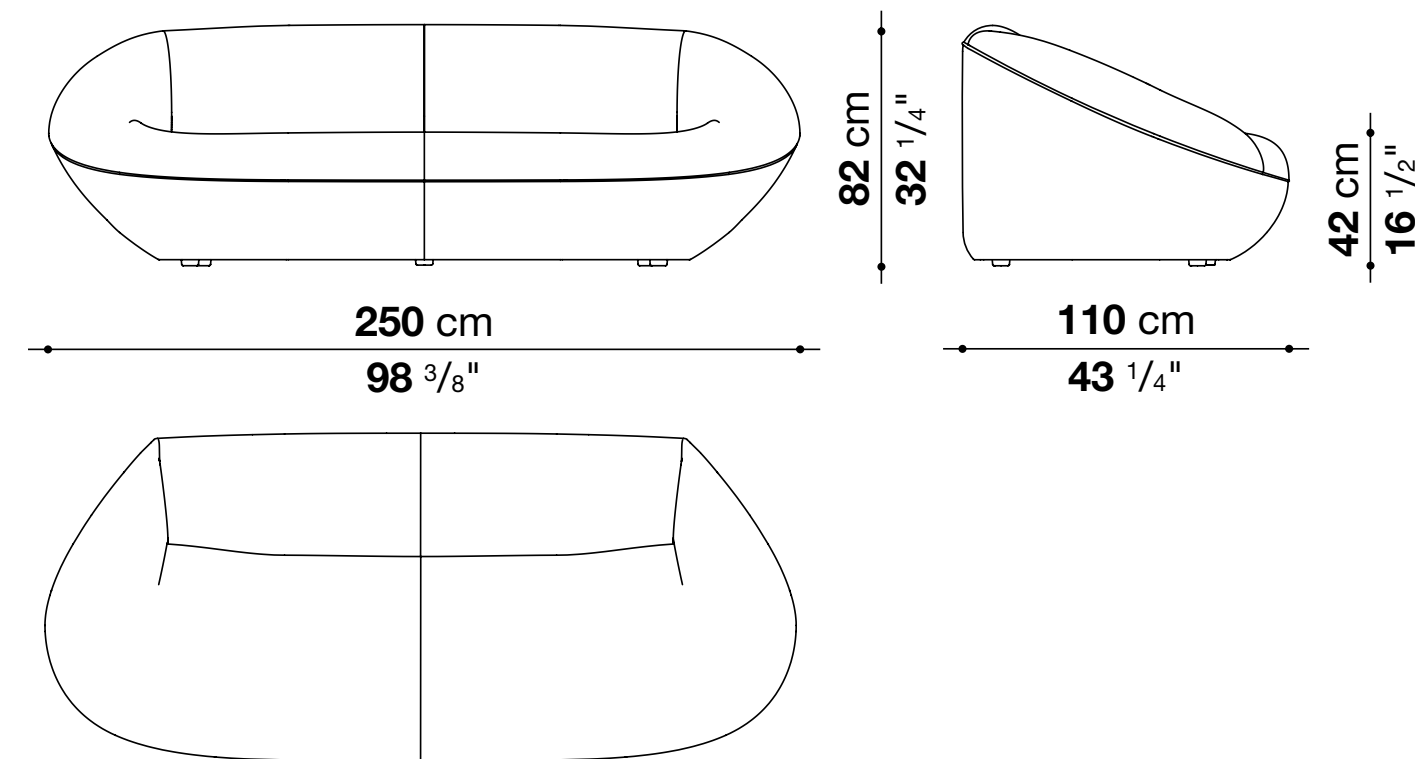

TRT118

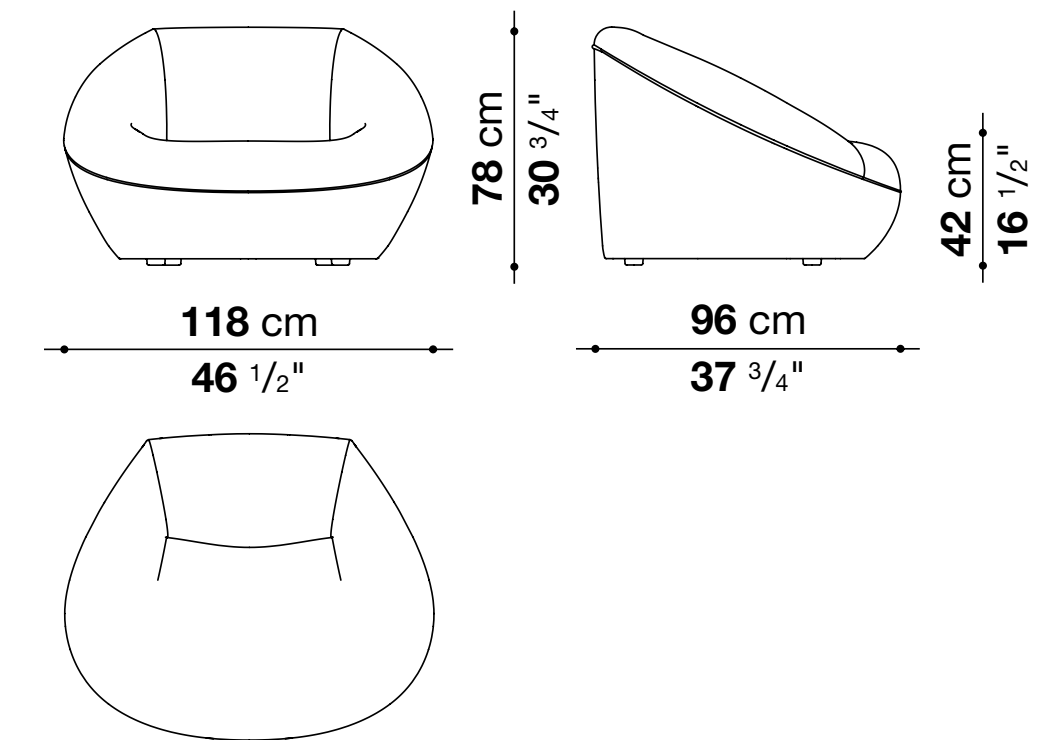

COVER

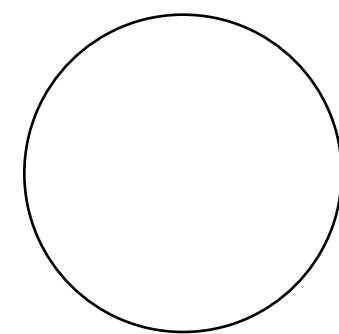

fabric

—Quiet
Lines
Complements
design Gabriel Tan



—Gabriel Tan

Gabriel Tan, born 1982, is a Singapore and New York based designer working across disciplines to find ways to combine tradition and technology, heritage and cosmopolitan aesthetics. In addition to collaborating with brands like Menu and Wallpaper*, Tan has also worked as a creative director for Turn Handles, Origin and Ariake, and spoken as a guest lecturer at several institutions. The works of his design practice, Gabriel Tan Studio, have been exhibited all over the world.



—Quiet Lines, design Gabriel Tan

“The bedroom is more than ever becoming a place for reflection, quietude, and rituals. Quiet Lines is a range of bedroom furniture that embraces a paradox: inviting rest while awakening the senses. Curved, padded surfaces bring tactility and comfort while dampening sound when objects are laced on them. The silhouette of each piece in the collection is composed of curved and straight lines, forming graphical compositions. Driven by circular design principles, each component in Quiet Lines has been designed to be easily disassembled and separated, so that each part can be individually reupholstered, refinished, or repaired when needed. This results in the reduction of waste and an extension of the product lifespan.”

—Gabriel Tan

—Quiet Lines Complements

design Gabriel Tan



[back to Products index](#)

[back to Quiet Lines chapter beginning](#)

B&B
ITALIA



In recent years, life and our priorities are migrating towards interior spaces, environments in which feelings of security and comfort contribute to physical and mental well-being. The bedroom is becoming more than ever a place for reflection and rituals. Quiet Lines, a transversal collection consisting of writing desk, bench, bedside table, and screen, is the result of research into serenity by Gabriel Tan and B&B Italia. The silhouette of each collection piece is made up of curved and straight lines, with a

striking graphic mark. The curved upholstered surfaces, a distinctive feature of the series, form a protective layer on which to sit or display objects. These sinuous lines provide tactility and comfort and muffle the sound of objects as they are placed on the shelves. The details are remarkable: the strap elements, the seams of the shelves and the hinges of the screen. The slender frames of the entire collection are composed of thin bronzed nickel painted steel profiles.



The writing desk, that can also be used as a vanity desk, is characterised by a useful inlet between the tabletop and the upholstered leather backrest, ideal for displaying books and objects. The bench, a versatile element that lends itself to various uses and environments, has a leather surface under the seat that can be used to store blankets, clothing and

objects. One of the features of the bedside table is that it can be used from different sides. The lower leather top lies on a curved surface and is suitable for storing books or electronic devices. The screen responds to the need to delimit and define spaces. It is proposed with three or four doors covered in leather that can be adjusted as desired.

—Quiet Lines Complements

design Gabriel Tan



[back to Products index](#)

[back to Quiet Lines chapter beginning](#)



B&B
ITALIA

—Quiet Lines Complements

design Gabriel Tan



[back to Products index](#)

[back to Quiet Lines chapter beginning](#)

B&B
ITALIA

—Quiet Lines Complements

design Gabriel Tan



[back to Products index](#)

[back to Quiet Lines chapter beginning](#)

B&B
ITALIA

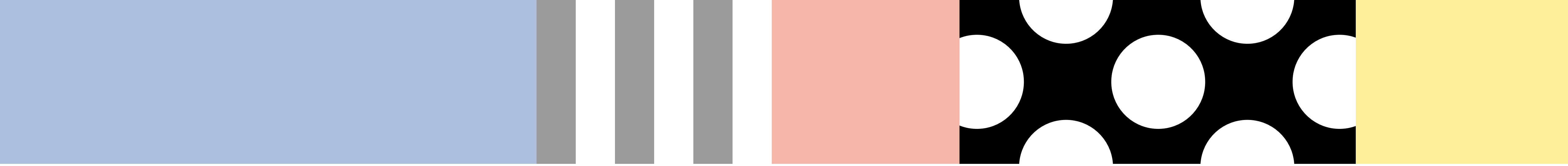

—Quiet Lines Complements

design Gabriel Tan



[back to Products index](#)

[back to Quiet Lines chapter beginning](#)

B&B
ITALIA

—Quiet Lines Complements

design Gabriel Tan

[back to Products index](#)

[back to Quiet Lines chapter beginning](#)



B&B
ITALIA

—Quiet Lines Complements

design Gabriel Tan



[back to Products index](#)

[back to Quiet Lines chapter beginning](#)

B&B
ITALIA

—Quiet Lines Complements

design Gabriel Tan



[back to Products index](#)

[back to Quiet Lines chapter beginning](#)

B&B
ITALIA

— Quiet Lines Complements

design Gabriel Tan

Writing-desk

QL120SC

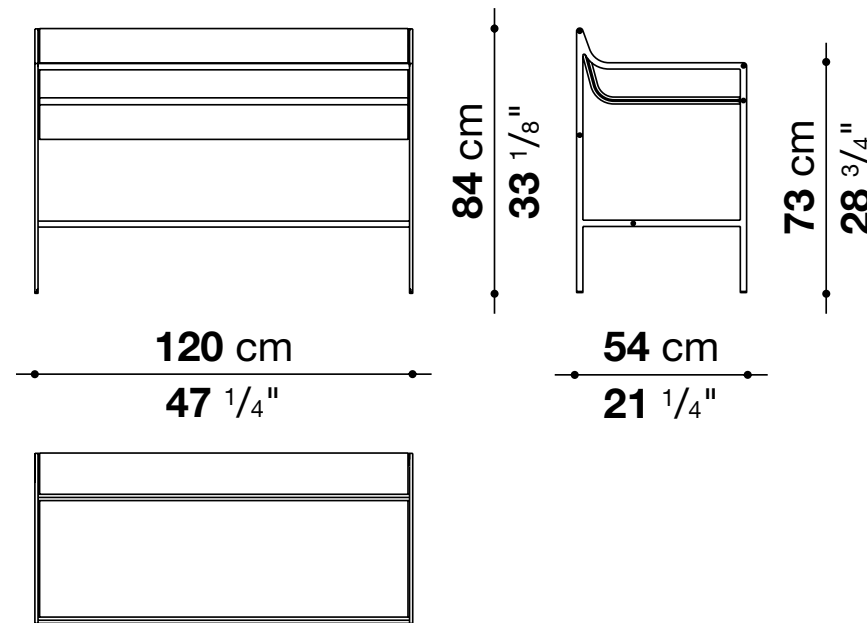

Night table

QL45C

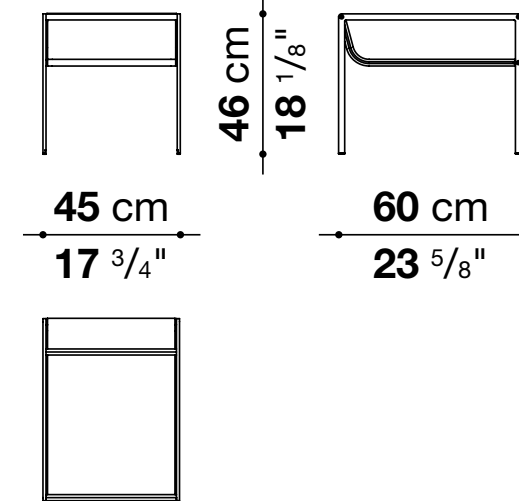

Bench

QL140P

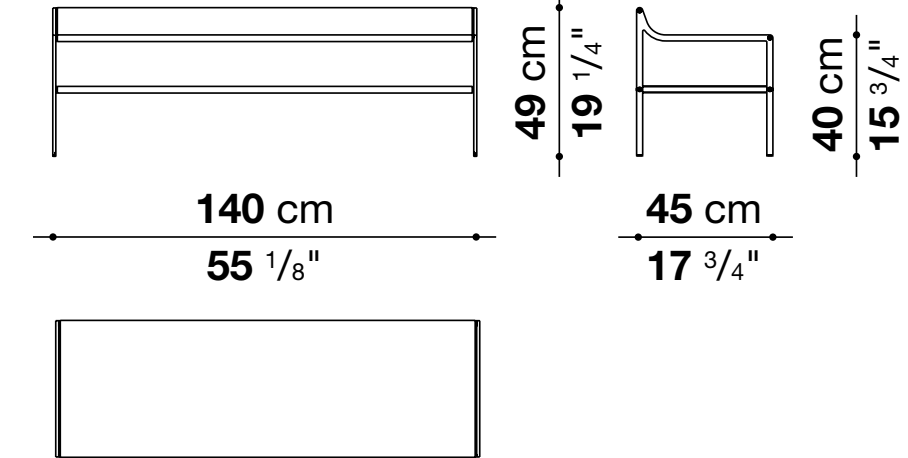

FRAME

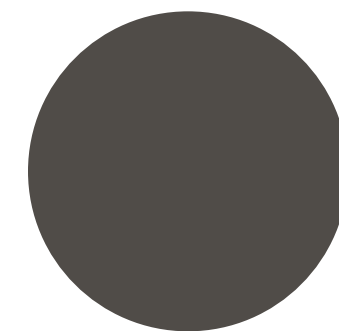

0174B
bronzed nickel
painted

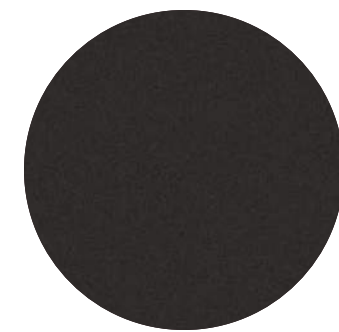

0170M
painted black chrome

TOP (writing-desk / night table)

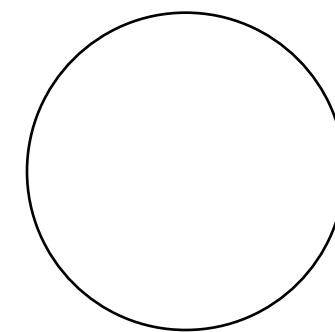

0200T
transparent
extra-light glass

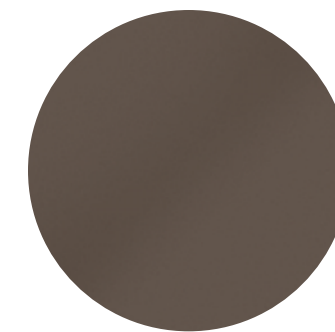

0129F
smoky glass

SECTIONS

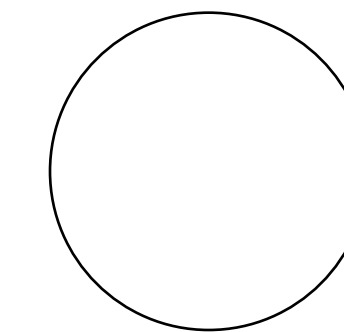

Alfa leather

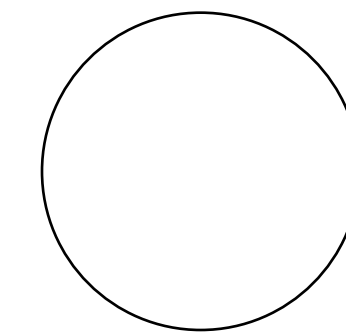

Gamma leather

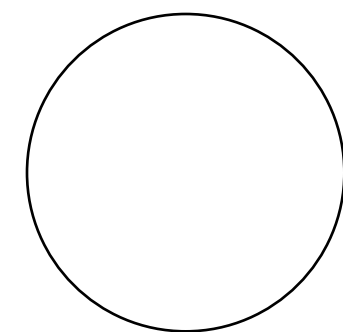

Kasia leather

—Quiet Lines Complements

design Gabriel Tan

Windscreen

QLPV3

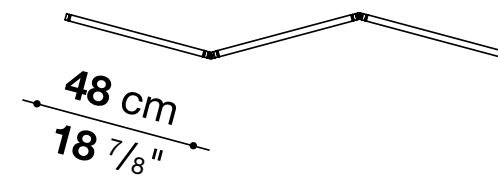
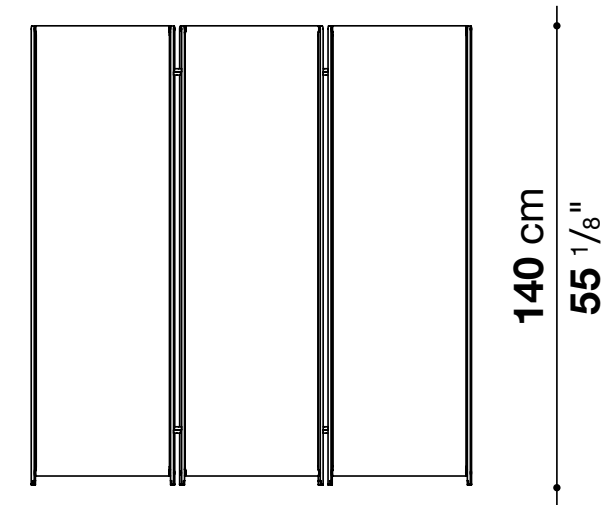

QLPV4

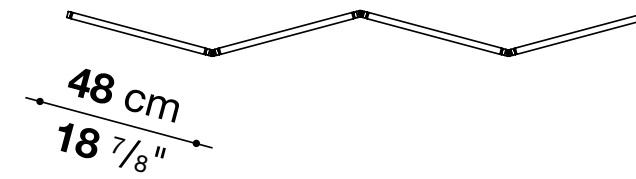
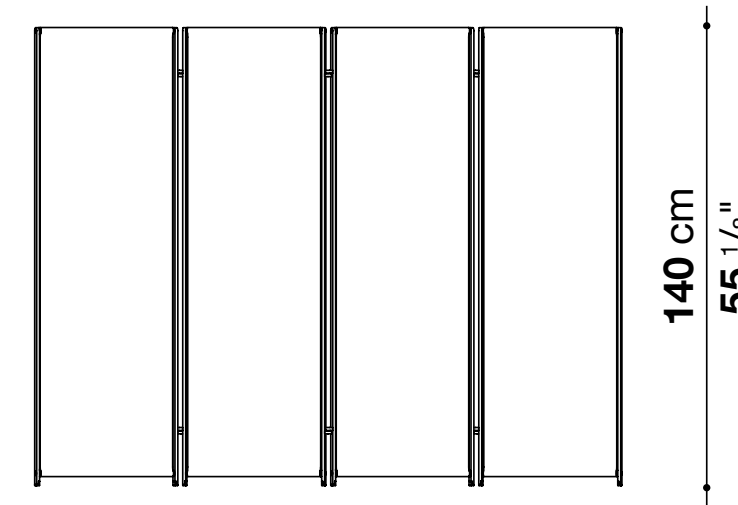

FRAME

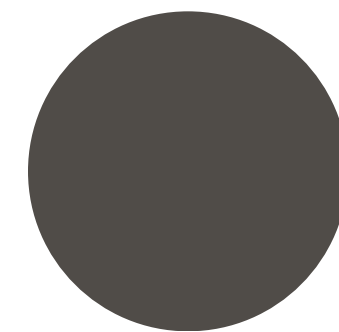

0174B
bronzed nickel
painted

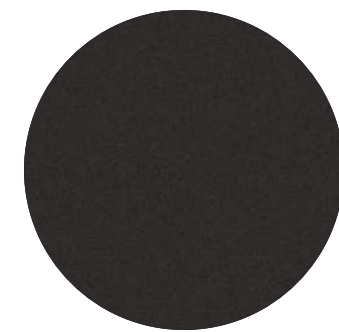

0170M
painted black
chrome

ELEMENTS

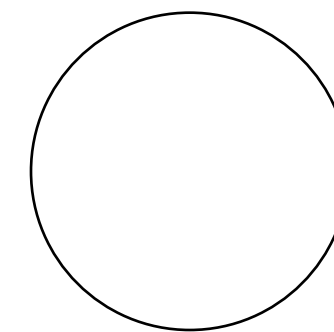

Alfa leather

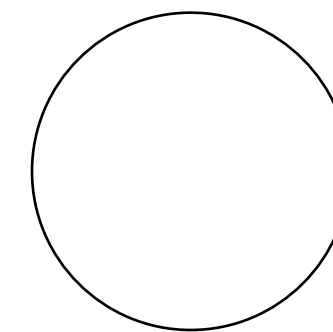

Gamma leather

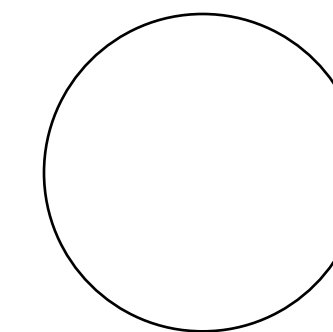

Kasia leather

—Lemante Small Tables

design Kensaku Oshiro



—Kensaku Oshiro

Kensaku Oshiro is an award-winning Japanese designer based in Milan, Italy.

Born in 1977 on Okinawa Island, Kensaku spent his formative years in Japan before moving to Italy. He graduated from the Scuola Politecnica di Design in Milan in 1999 and, after significant work experiences at renowned design studios in Milan (Lissoni & Partners) and London (Edward Barber & Jay Osgerby), he founded his own studio in Milan in 2015 and since then he has been collected several international awards.



—Lemante, design Kensaku Oshiro

“Geometry is a source of creativity. With a simple gesture it opens up a world of infinite possibilities. Lemante was born this way, in a simple way, from two squares.”

—Kensaku Oshiro

—Lemante

Small Tables

design Kensaku Oshiro

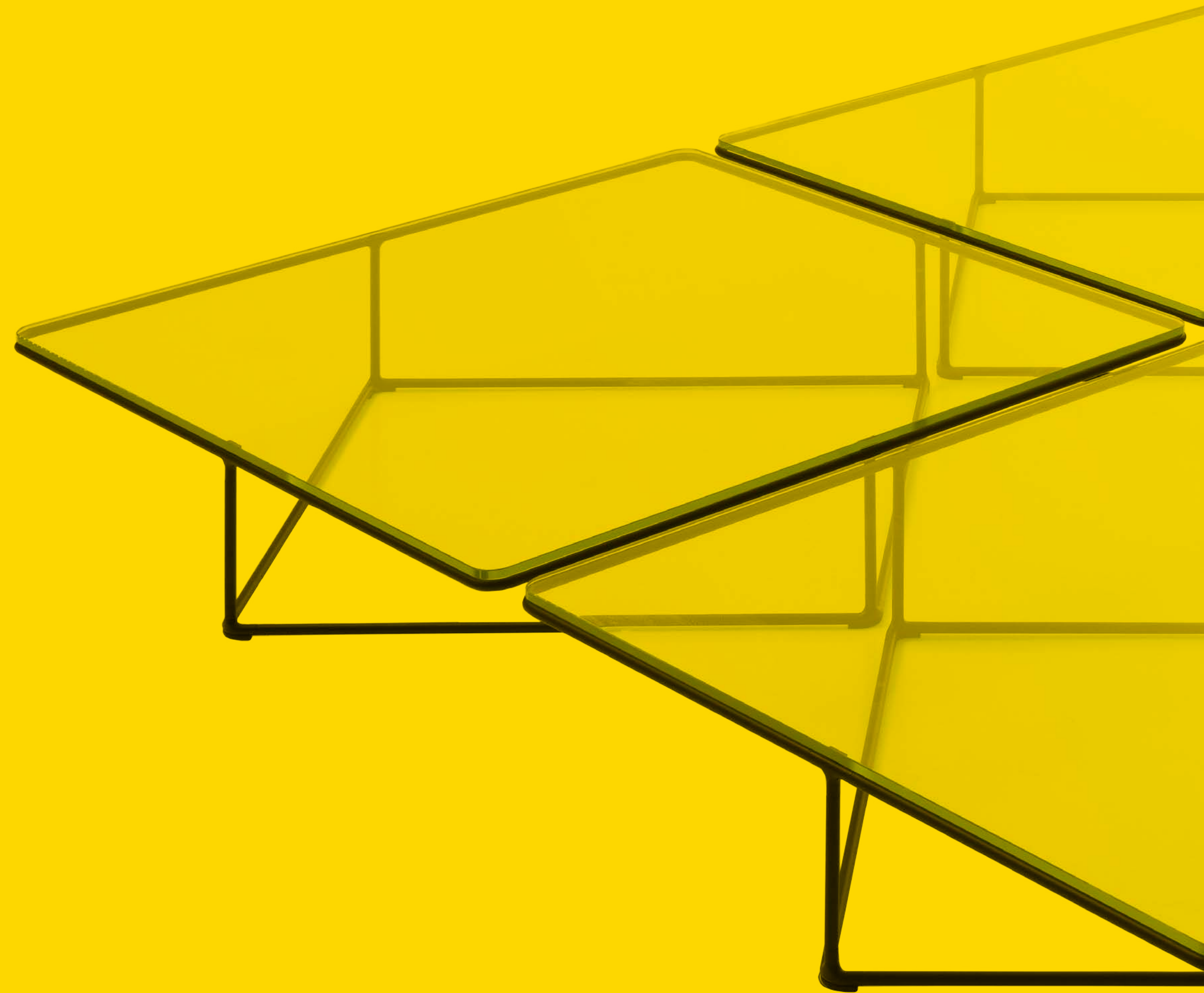

[back to Products index](#)

[back to Lemante chapter beginning](#)

B&B
ITALIA



Lemante is a collection of small tables replated with striking stylistic signs and with a strong biographical note for its creator, Japanese designer Kensaku Oshiro. The collection refers to organic forms found in nature juxtaposed with the more essential lines of the structure and is based on a simple geometric idea: two parallel squares rotated and offset by 45°. Prominent among the structural elements are the slender structure in metal rod and the corner joint composed of an aluminium

casting, also repeated for the feet. The tops are available in extra light transparent glass or amber and quartz grey fused glass, a process that creates organic textures and irregularities on the surface for a distinct tactile effect. Two materials are available for the base, black Marquina marble or glossy lacquered in numerous shades. The collection comprises four interlocking sizes for infinite decorative compositions.

—Lemante

Small Tables

design Kensaku Oshiro

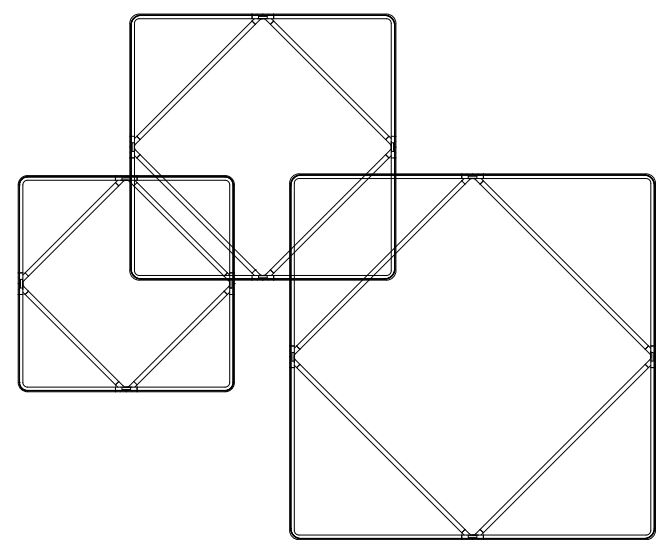

—Lemante

Small Tables

design Kensaku Oshiro

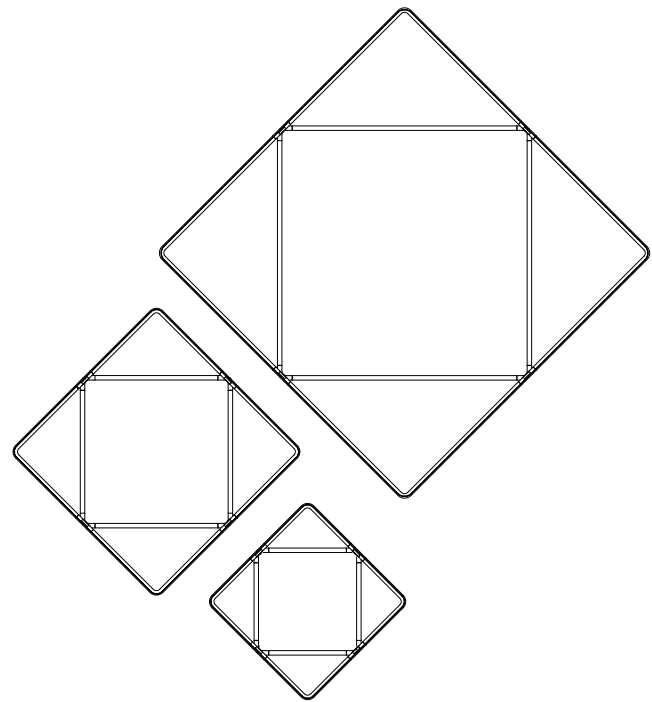

[back to Products index](#)

[back to Lemante chapter beginning](#)

B&B
ITALIA

—Lemante Small Tables

design Kensaku Oshiro

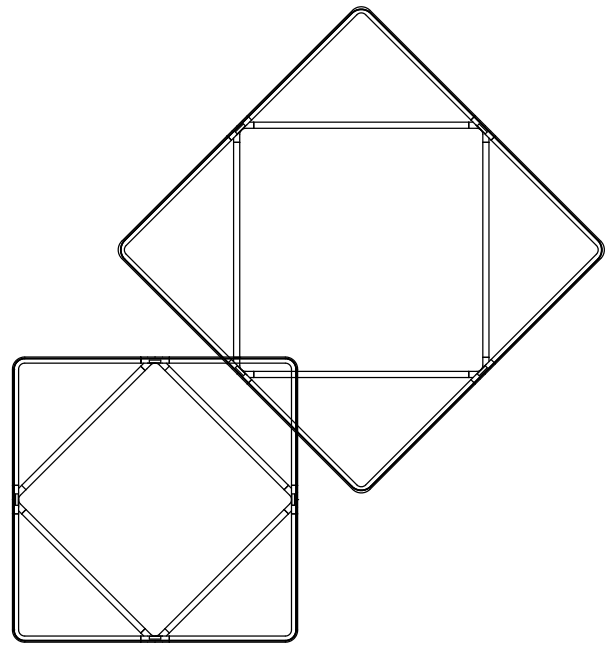

[back to Products index](#)

[back to Lemante chapter beginning](#)

B&B
ITALIA

—Lemante Small Tables

design Kensaku Oshiro



[back to Products index](#)

[back to Lemante chapter beginning](#)

Lemante

Small Tables

design Kensaku Oshiro

LEM110

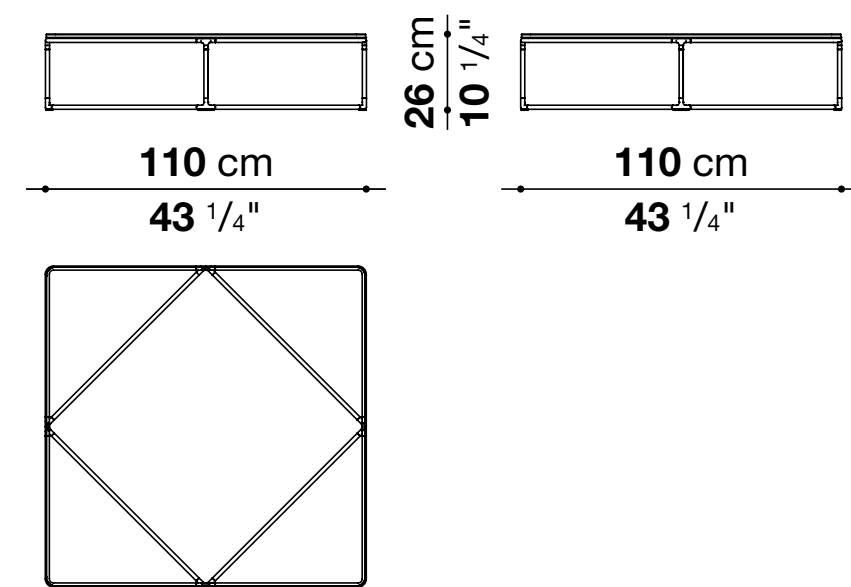

LEM80

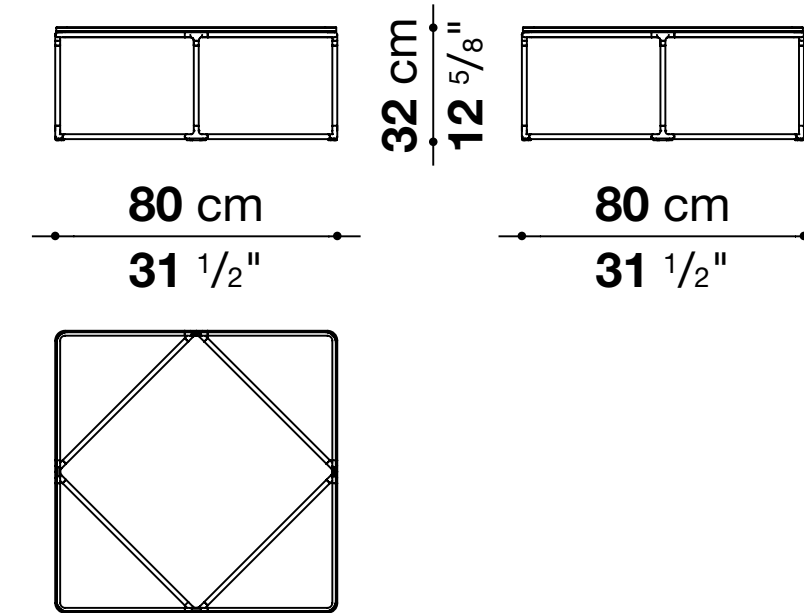

LEM65

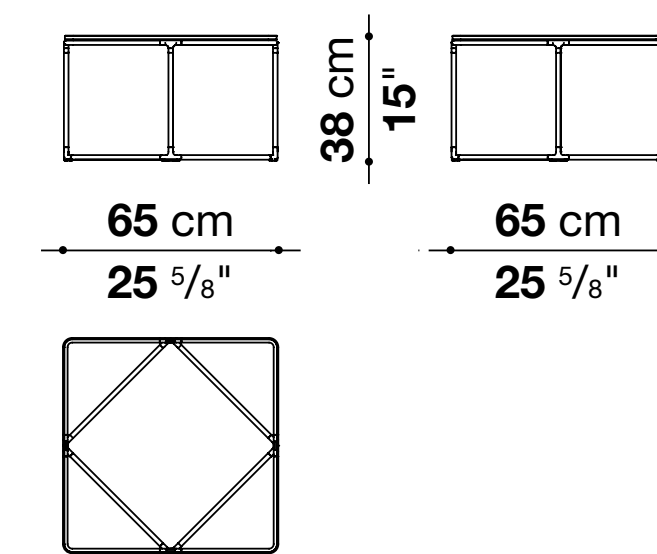

LEM45

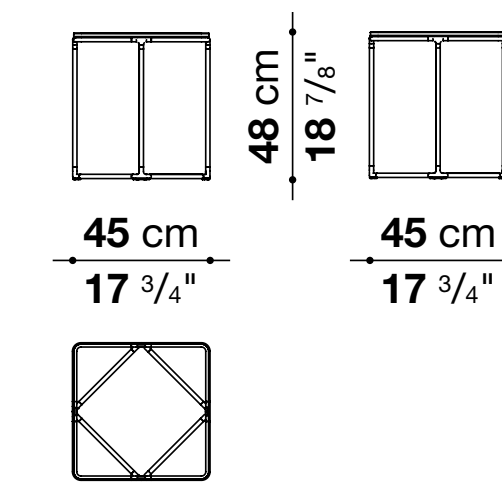

FRAME

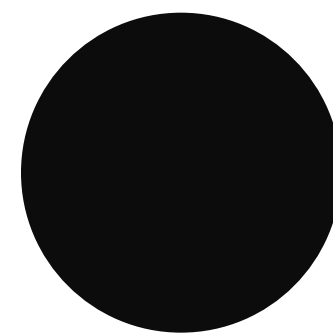

0168N
matt black painted
aluminium

TOP

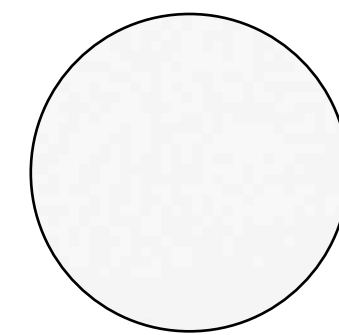

0200T
transparent
extra-light glass



0836B
quartz grey
molten glass



0502A
amber molten glass

LOWER TOP

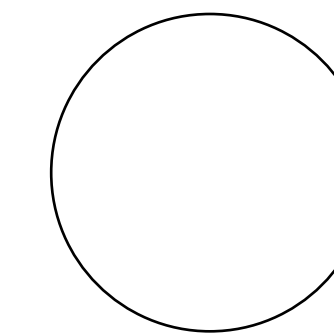

**All the glossy
colours range**



0805N
Marquinia black
marble natural

—Flair O' Couture Chair

design Monica Armani



—Flair O' Couture, design Monica Armani

“To create the Flair O' seating collection, I was inspired by cape dresses, which were so striking in the 1960s, and this is well conveyed by my design. A design with a strong sartorial soul, so how could I not think of a new ‘couture’ version? From this idea, the new Flair O' Couture chair was born. For her, I created an evening dress, radiant and fascinating, with a design balancing solids and transparencies.”

—Monica Armani

—Flair O' Couture Chair

design Monica Armani

[back to Products index](#)

[back to Flair O' Couture chapter beginning](#)

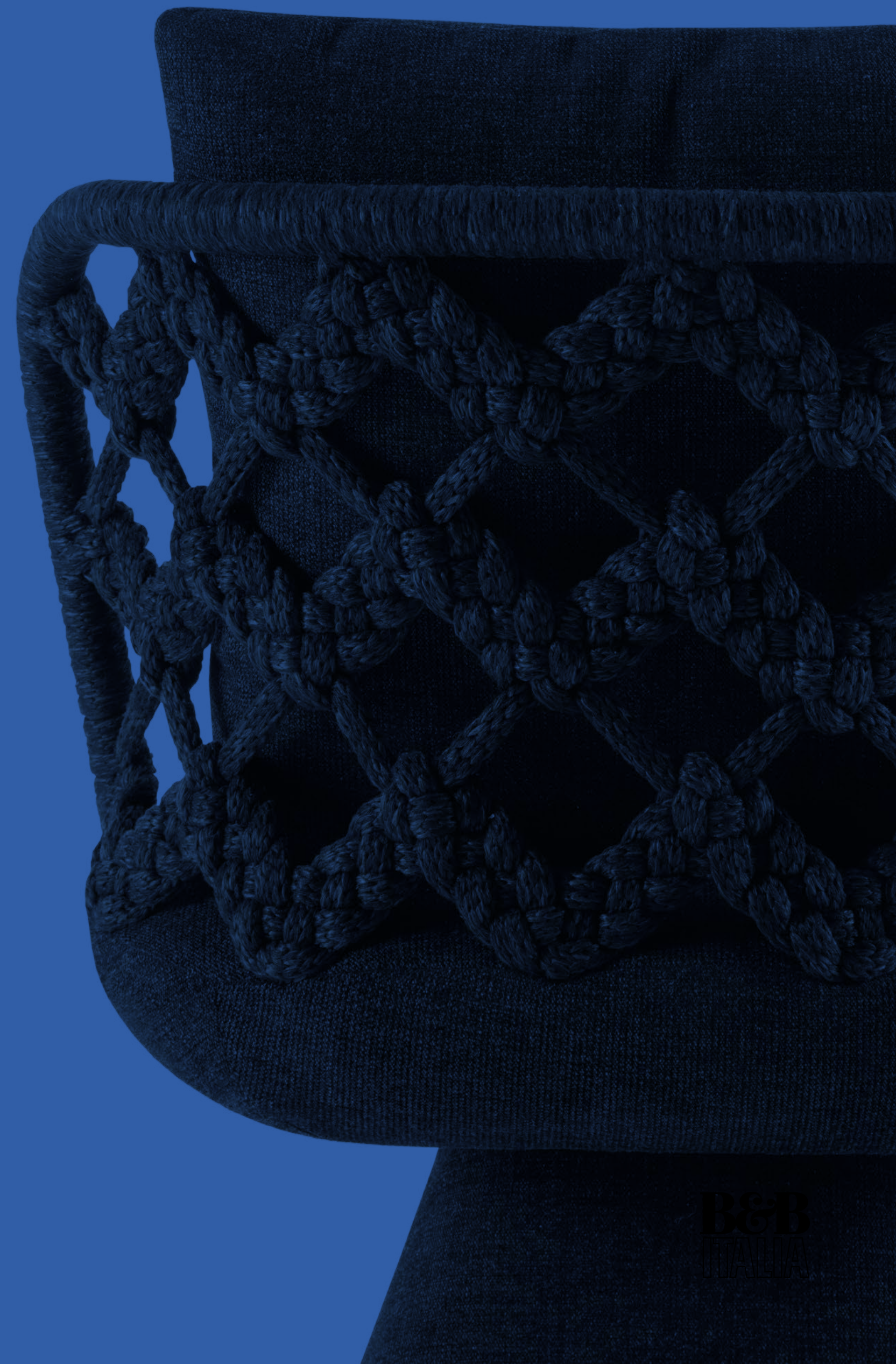



Following the success of Flair O', a series of elegantly designed chairs available in indoor and outdoor versions, Monica Armani proposes Flair O' Couture. Geometrically similar to the previous designs this new chair boasts a woven backrest made using a special circular loom (tombolo) in line with an ancient weaving technique typical of the area where B&B Italia is located. To fine-tune it, Monica Armani collaborated with unPIZZO, a design studio based in Cantù, which specializes in the recovery and development of traditional weaving techniques

revisited in a contemporary key and applied to the furnishing sector. The internal structure of the aluminium backrest is in fact completely enveloped by the weaving of polypropylene ribbons, available in four colours, and rests on a truncated cone-shaped foot with a lenticular base. Two padded cushions complete the chair, defining the shape and providing even more comfort. Flair O' Couture is a functional and versatile yet technical and high-performance product.

—Flair O' Couture Chair

design Monica Armani



—Flair O' Couture Chair

design Monica Armani

FC60S_F

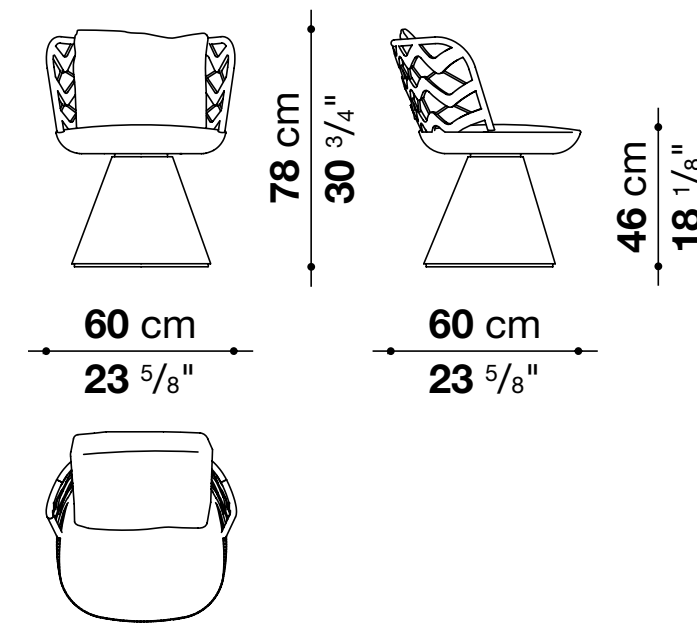

FC60S_M

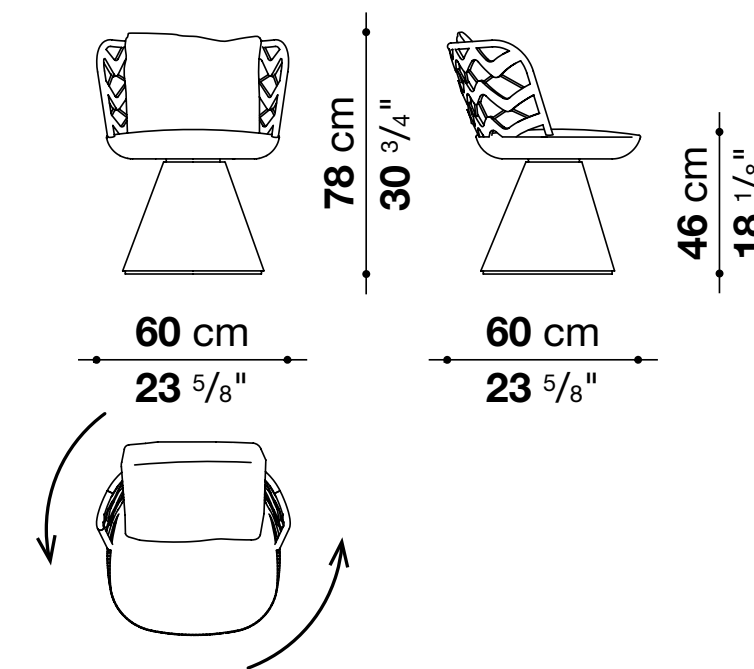

COVER

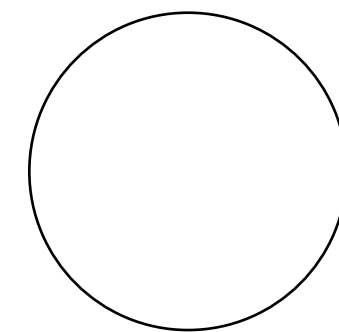

fabric

BACK INTERLACING

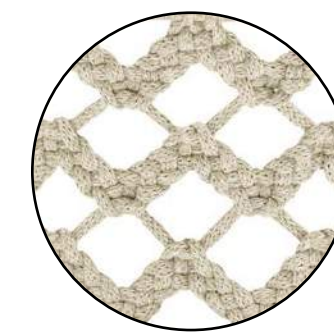

0579E
ecru polypropylene

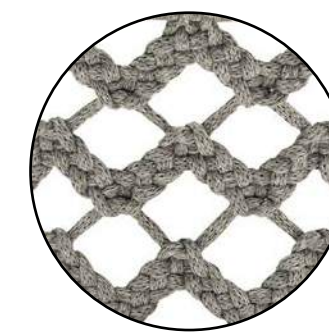

0602G
grey polypropylene

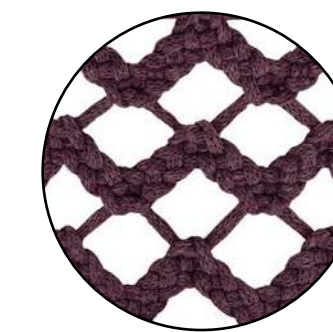

0704P
plum polypropylene

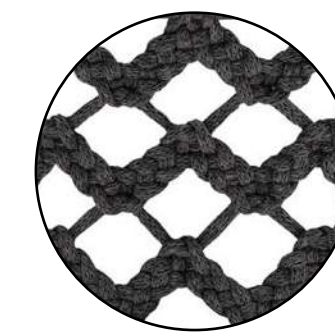

0689N
black polypropylene

—Heri O' Chair

design Monica Armani



—Heri O', design Monica Armani

“Heri O', simple yet sophisticated, is a symbol balancing memory and contemporaneity. I created a chair that immediately welcomes you and makes you acknowledge it. A decisive, tense but also sinuous graphic mark that delineates the structure and accommodates the upholstered seat.”

—Monica Armani

—Heri O' Chair

design Monica Armani

[back to Products index](#)

[back to Heri O' chapter beginning](#)



B&B
ITALIA

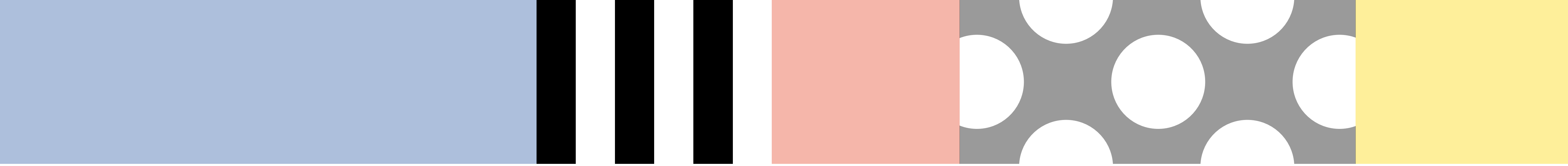

Seemingly elementary, Heri O' by Monica Armani combines elegance, essentiality and charm, and nods to the '60s. An object whose shapes and key colour hark back to the pop side of that era. The name Heri O' comes from the combination of the word heritage with O'. Heritage for the clear references to the archetypes of round wooden chairs, O', like the Flair O' and Allure O' collections, is an homage to the timeless style icon Jackie O'.

With a clean design, the chair, light in its forms, is made of a curved and joined wooden frame, a balance between tradition and novelty. The upholstered cushions are made of a foamed metal base covered in fabric. Heri O' has a thousand faces with its countless finishes, from light and black brushed ash to glossy lacquer in different colours, combined with B&B Italia's extensive textile collection for the seat and back cushions.

—Heri O' Chair

design Monica Armani

[back to Products index](#)

[back to Heri O' chapter beginning](#)



B&B
ITALIA



—Heri O' Chair

design Monica Armani



—Heri O' Chair

design Monica Armani



[back to Products index](#)

[back to Heri O' chapter beginning](#)

B&B
ITALIA

—Heri O' Chair

design Monica Armani



[back to Products index](#)

[back to Heri O' chapter beginning](#)

B&B
ITALIA

—Heri O' Chair

design Monica Armani

HR60

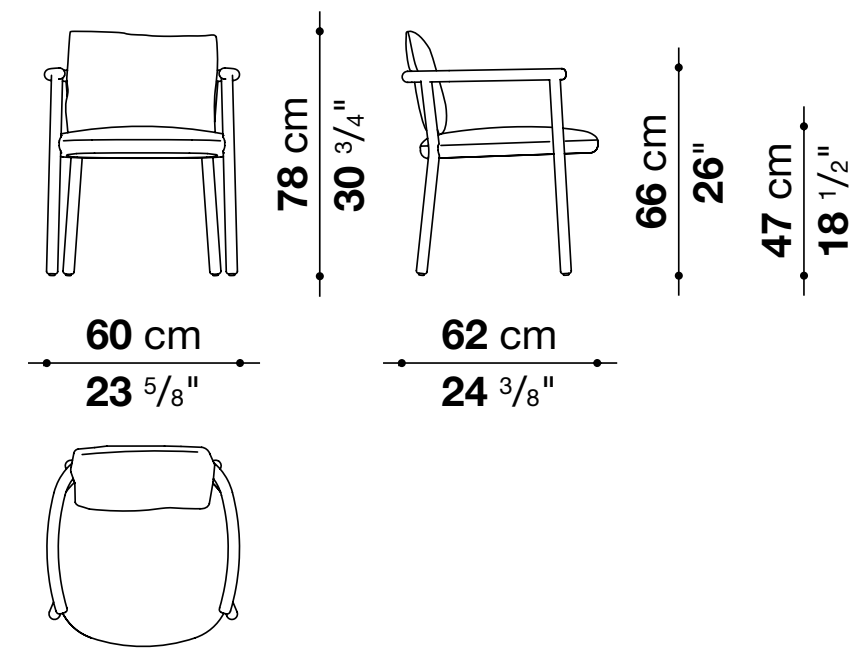

FRAME



0421C
brushed light ash



0494N
brushed black ash

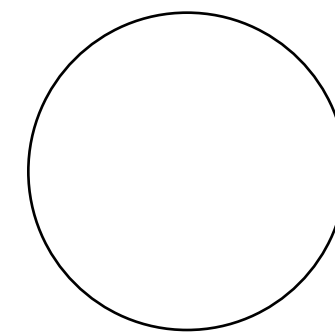

all the colours
glossy range

COVER

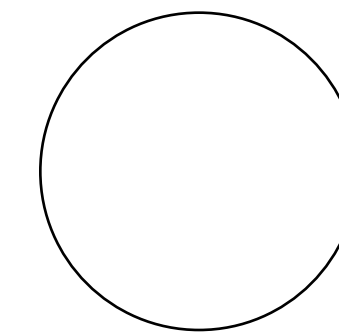

fabric

—Tetrami Storage units

design Naoto Fukasawa



—Tetrami, design Naoto Fukasawa

“For some reason, I like horizontal rectangles. Most of these typologies of shelves feature legs, but this one has two vertical partitions that I extended to form legs. I think I’ve achieved the minimalist shape that everyone has envisioned. I think it’s beautiful wherever and however you use it.”

—Naoto Fukasawa

—Tetrami

Storage units

design Naoto Fukasawa

[back to Products index](#)

[back to Tetrami chapter beginning](#)

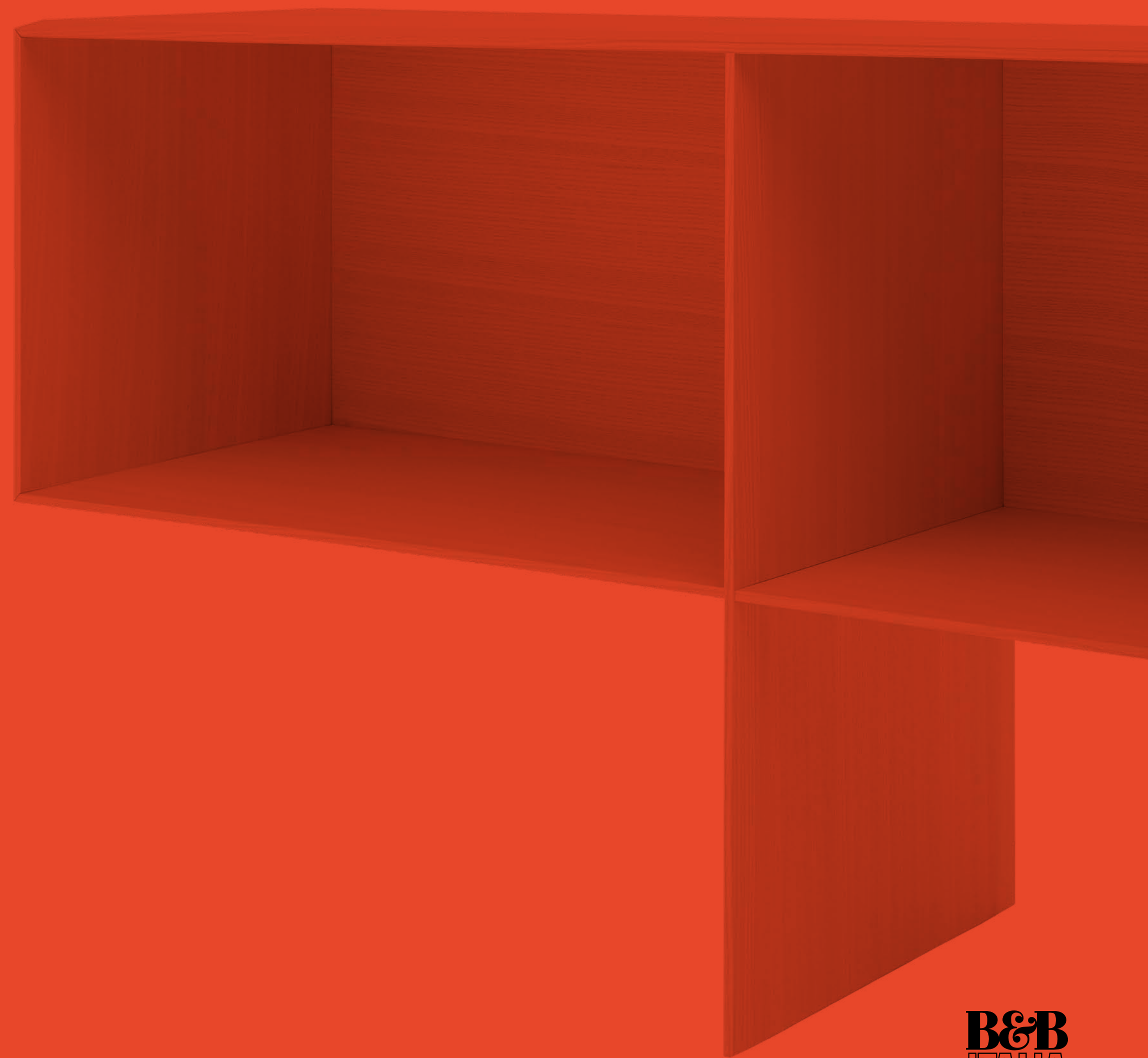



A linear graphic character, with a strong functional impact, distinguishes Tetrami, the new collection of free-standing containers born from the creative flair of the Japanese master Naoto Fukasawa. The rectangle is the star element, as are the feet that unexpectedly materialise as vertical extensions of the two central partitions. The object is created thanks to the experience of expert cabinetmakers and is composed of extra thin wooden lists.

Generously sized but not bulky, Tetrami is 210 cm wide and 41 cm deep, and available in two heights. The taller model can be used as a sideboard, while the lower version can complement a sofa or double as a TV stand. Tetrami is available as an open cabinet or with drawers, making it a functional container. The grain and texture of light and black brushed ash make it an elegant and refined piece of furniture. The cabinets are also available in a two-tone version by combining the two ash tones for the finish of the outer and inner surfaces.

—Tetrami

Storage units

design Naoto Fukasawa



[back to Products index](#)

[back to Tetrami chapter beginning](#)

B&B
ITALIA

—Tetrami

Storage units

design Naoto Fukasawa



—Tetrami

Storage units

design Naoto Fukasawa



[back to Products index](#)

[back to Tetrami chapter beginning](#)

B&B
ITALIA

—Tetrami

Storage units

design Naoto Fukasawa



[back to Products index](#)

[back to Tetrami chapter beginning](#)

B&B
ITALIA

Tetrami

Storage units

design Naoto Fukasawa

TET52

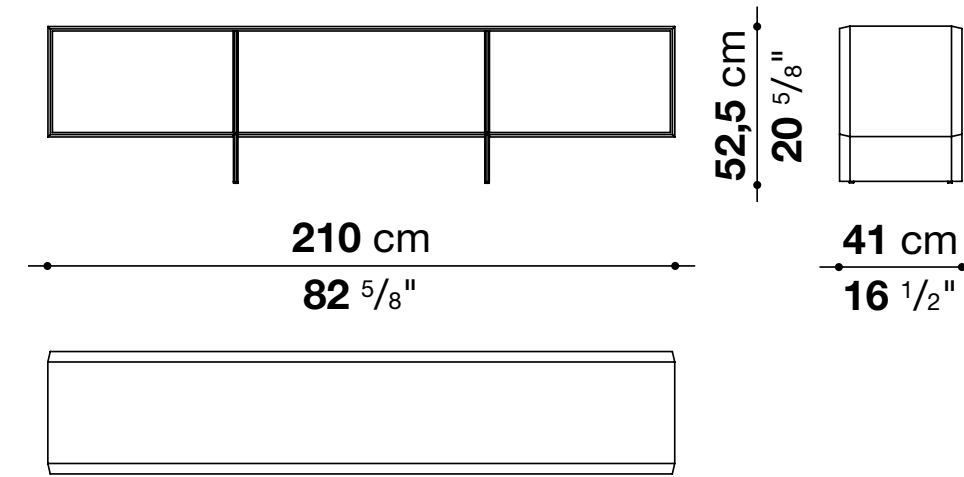

TET66

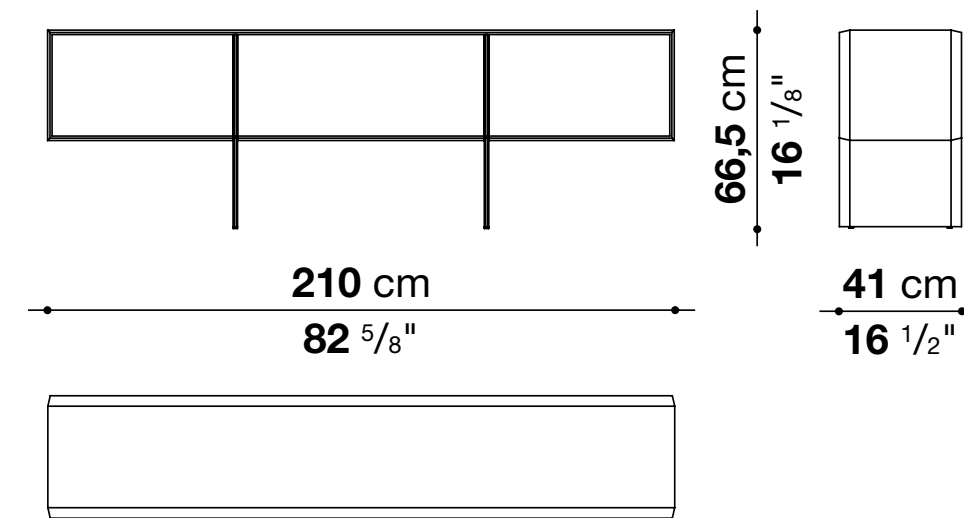

FRAME (VERSION IN ONE COLOUR)



0421C
brushed light ash

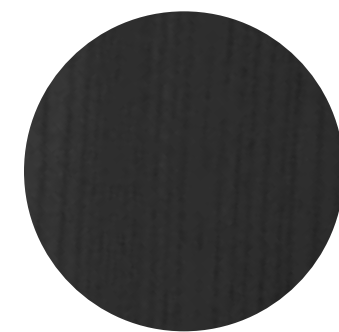

0494N
brushed black ash

TET52C

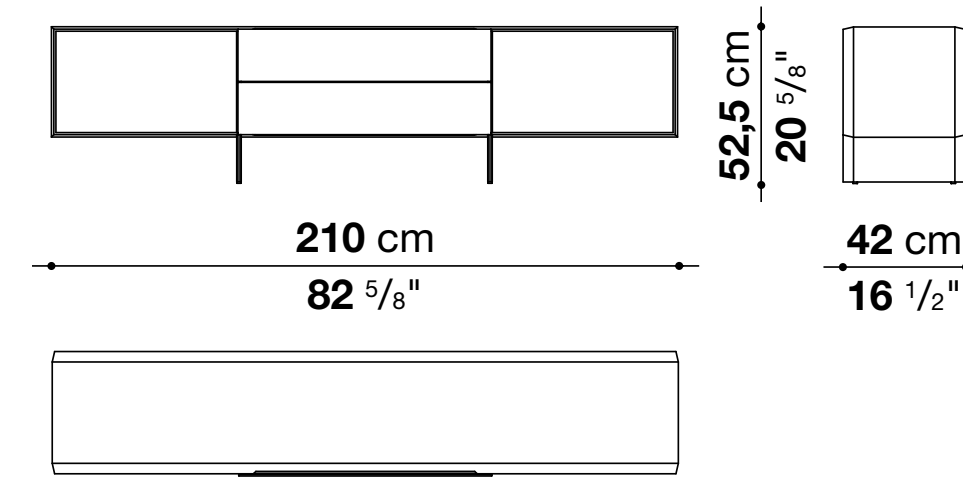

TET66C

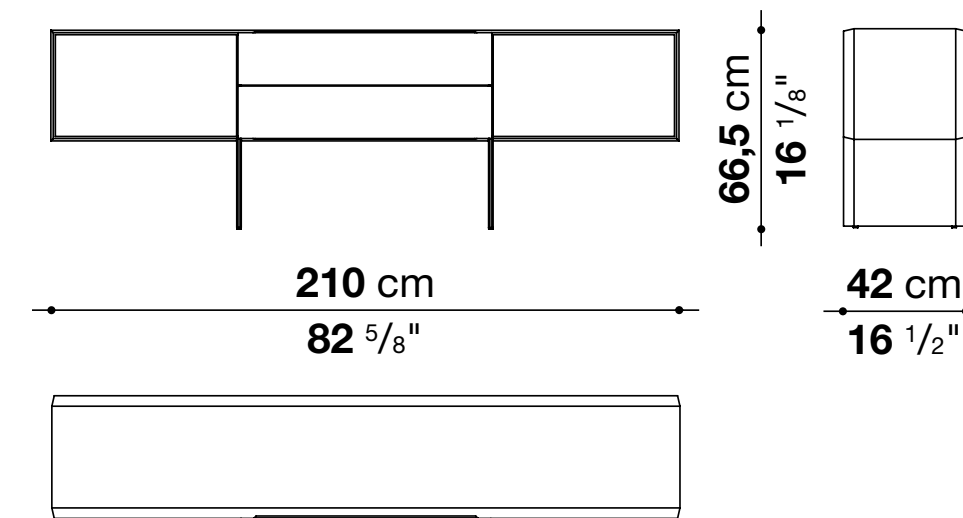

FRAME (VERSION IN TWO COLOUR)

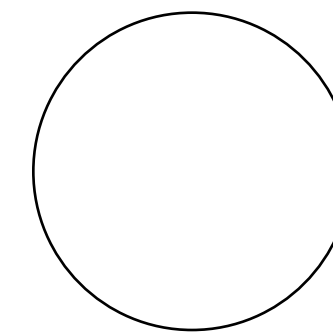

combination of internal
and external structure
in the two colors of ash

—New Textiles 2023



—New textiles 2023

"Like every season, we have renewed our fabric collection by thinking like a 'design house' - rather than a fashion house - an update of fabrics, taste and aesthetics for the new year. B&B Italia is a leader in the contemporary world, and we must continuously affirm our vocation, our choice to be always, constantly and slightly ahead."

—Piero Lissoni



New designs and collections can only be complemented by new fabrics and palettes. B&B Italia's textile offer is expanded to best suit the new modular sofa system or the new seating offerings. Therefore, the fabric Lagos is added to the B&B Italia range, a refined houndstooth that lends itself both to the role of faux-uni for the entire sofa and as a decorative element for cushions and backrests. Lagos is made of a wool blend and is available in 13 colours. In combination, one can opt for the new bouclé Lissy, woven with the same yarn in the same 13 shades.

The new Liam polka dot print fabric is the result of a sustainable innovation introduced by the company's CR&S team: a 100% biodegradable polyester (lab-tested to break down into compost and soil without harming the environment) and toxin-free without releasing harmful microplastics into the environment. The fabric is manufactured in controlled factories that follow the strict OceanSafe standards. The supplier yarn and weaving mill are certified cradle to cradle, and the ink used for printing is Oeko-tex certified. Liam will be available in 4 variations, always with an écru background, with a black, blue, green or red polka dot.

—New textiles 2023 Lagos

Composition

| | |
|-----------|-----|
| Acrylic | 28% |
| Wool | 28% |
| Polyester | 16% |
| Viscose | 12% |
| Cotton | 10% |
| Linen | 6% |

Fire resistant

BS 5852 - 0&1
TB 117 - 2013

Fabric dedicated to the Dambo sofa system designed by Piero Lissoni

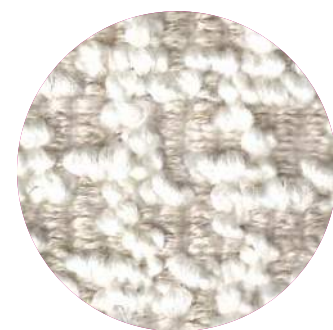

2839100



2839207



2839280

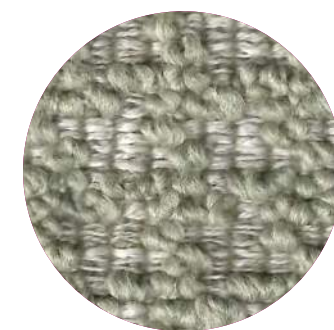

2839440

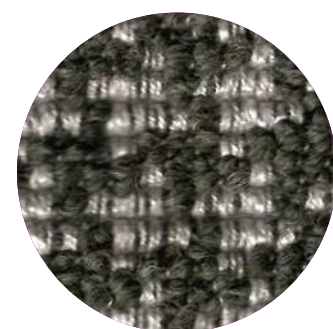

2839421

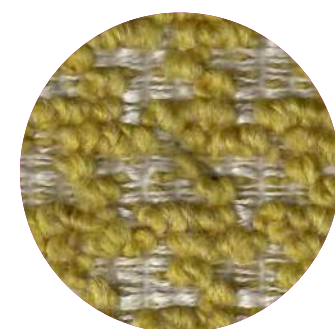

2839500



2839251



2839150

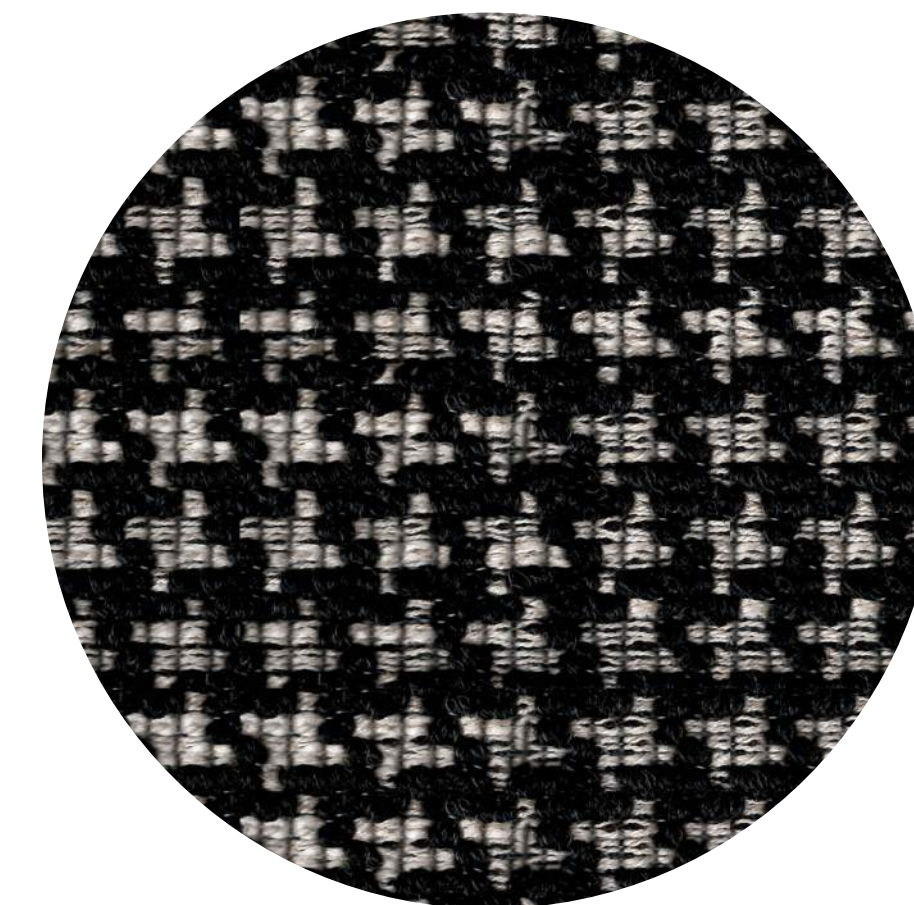

DETAIL



2839800

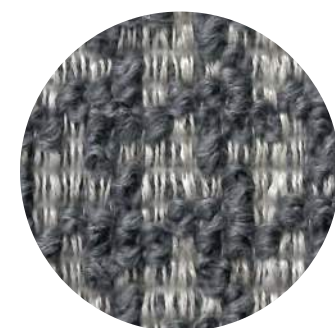

2839810



2839750



2839370



2839313

—New textiles 2023 Lissy

Composition

| | |
|-----------|-----|
| Acrylic | 30% |
| Wool | 28% |
| Polyester | 16% |
| Viscose | 11% |
| Cotton | 10% |
| Linen | 5% |

Fire resistant

BS 5852 - 0&1
TB 117 - 2013



2840100

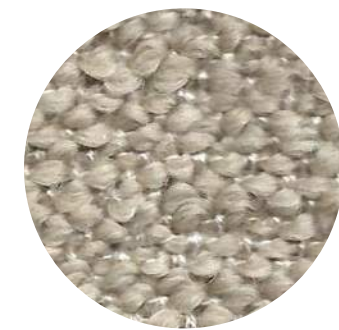

2840207



2840280

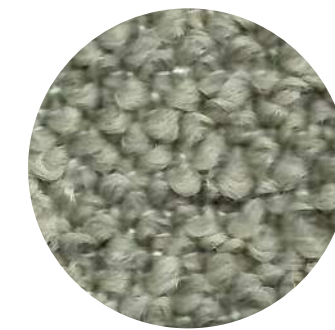

2840440



2840421

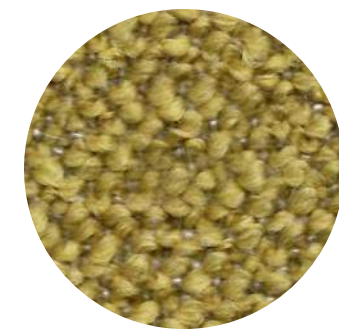

2840500



2840251

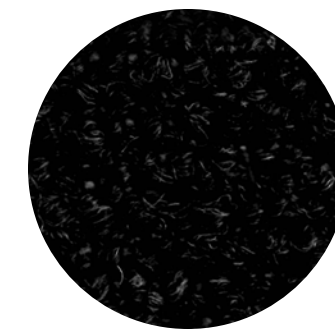

2840150



DETAIL



2840800



2840810



2840750



2840370



2840313

—New textiles 2023

Liam

Composition

Acrylic 100%

Fire resistant

BS 5852 - 0&1
TB 117 - 2013

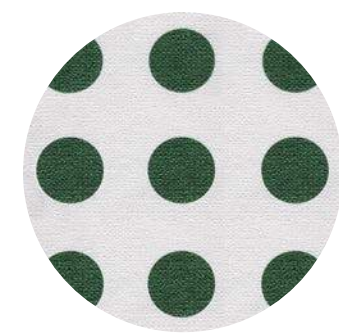

2842140

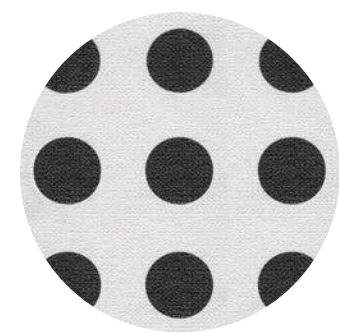

2842150

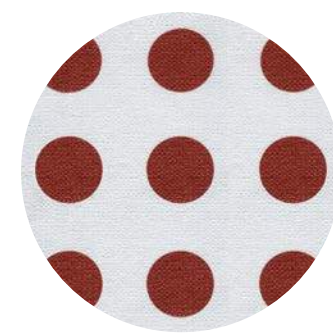

2842170

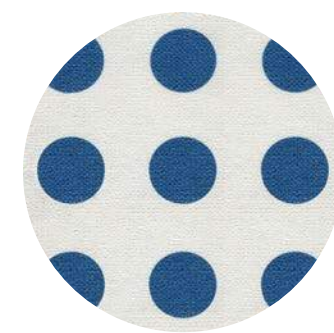

2842180

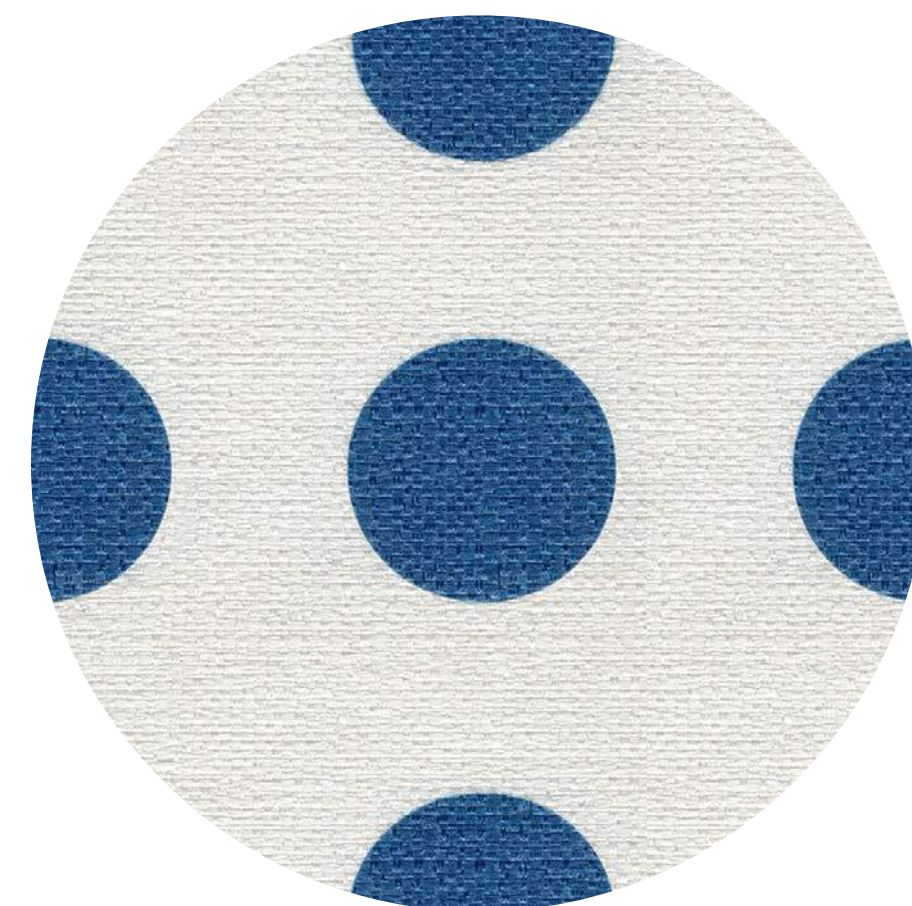

DETAIL

—Fabric range extensions 2023

Milo

Composition

Pile

Wool 100%

Base

Wool 64%

Cotton 26%

Fire resistant

BS 5852 - 0&1

TB 117 - 2013



2540370
Brick



2540500
Yellow

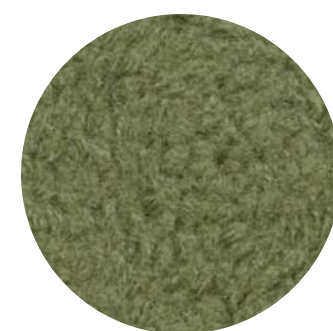

2540400
Green



DETAIL

—Products
Range
Extensions
2023



—Products Range Extensions 2023

Allure O', Table
design Monica Armani

Tobi-Ishi, Table
design Edward Barber & Jay Osgerby

Alys 10, Bed
design Gabriele & Oscar Buratti

Serie UP
Compasso d'Oro
design Gaetano Pesce



—Allure O', design Monica Armani

Only two years after its launch, the Allure O' table is already an icon of style and elegance. The collection, a heartfelt tribute to glamour reinterpreted in a contemporary guise, has been extended with the addition of new finishes. The square table and the 225 cm rectangular one are now available with the enamelled stoneware top in four colours, including the new milk white, to be combined with glossy

lacquered colours for the base. A new rectangular version is also added to the series, characterised by a super length of 320 cm which incorporates the wood and lacquered finishes in the collection. With its numerous variants, Allure O' transforms the tradition of being at the table into a new present, beyond nostalgia and towards a new way of experiencing domestic luxury under the banner of a revisited allure.

—Allure O' Table

design Monica Armani

[back to Products index](#)

[back to Range Extensions 2023 chapter beginning](#)

B&B
ITALIA



—Allure O' Table

design Monica Armani

The 225 cm square and rectangular table can now also have a glossy glazed stoneware top in four colours.



—Allure O' Table

design Monica Armani

TAO155QGR

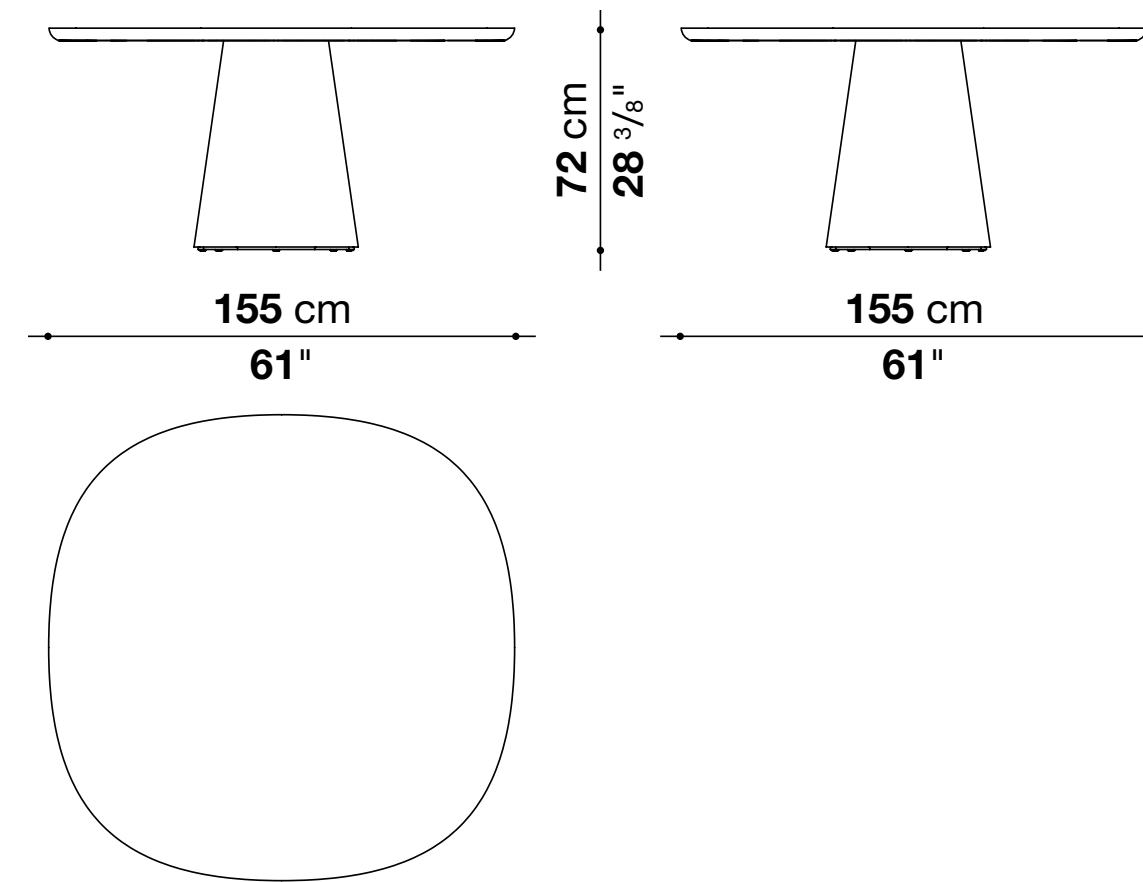

TAO225GR

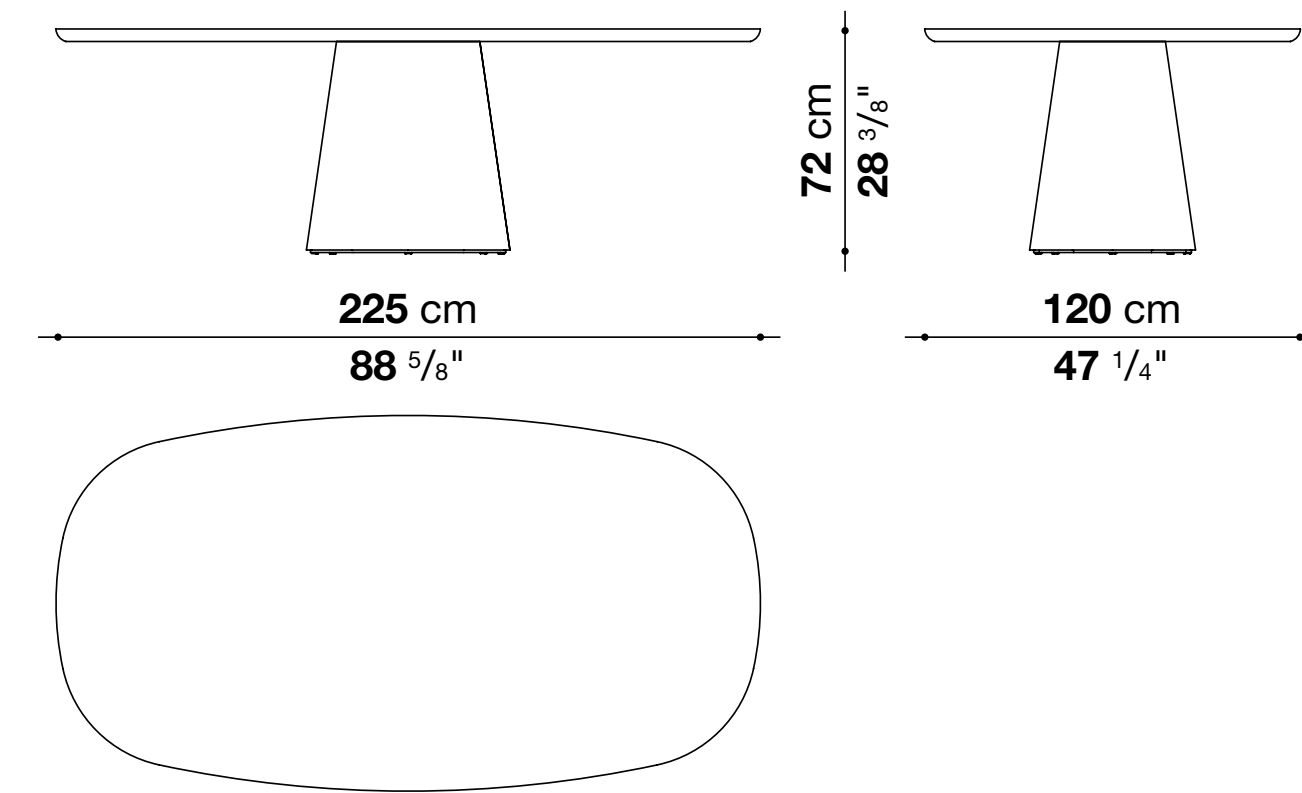

NEW FINISHES

TOP

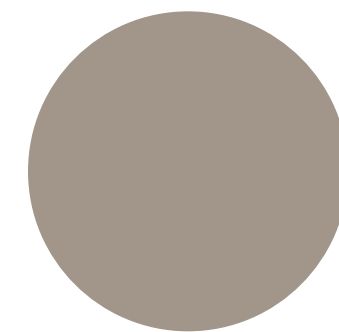

0613T
glossy dove grey
stoneware

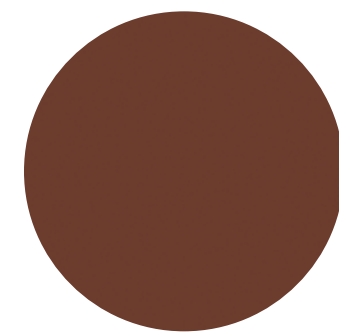

0784A
glossy clay
stoneware

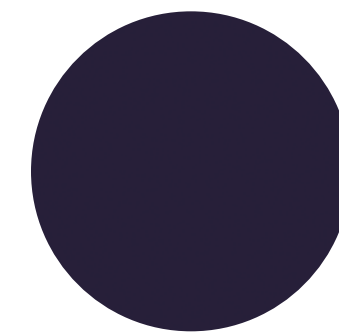

0892B
glossy ocean blue
stoneware



0851B
glossy milk white
stoneware

BASE-FRAME

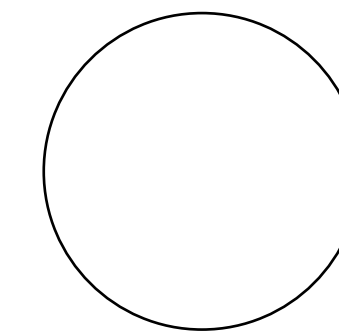

all the range of
glossy lacquered
colours

—Allure O' Table

design Monica Armani

A new rectangular version is added to the series characterized by a super length of 320 cm which incorporates the wood and lacquered finishes in collection.

[back to Products index](#)

[back to Range Extensions 2023 chapter beginning](#)



B&B
ITALIA

—Allure O' Table

design Monica Armani



[back to Products index](#)

[back to Range Extensions 2023 chapter beginning](#)

B&B
ITALIA

—Allure O' Table

design Monica Armani

TAO320

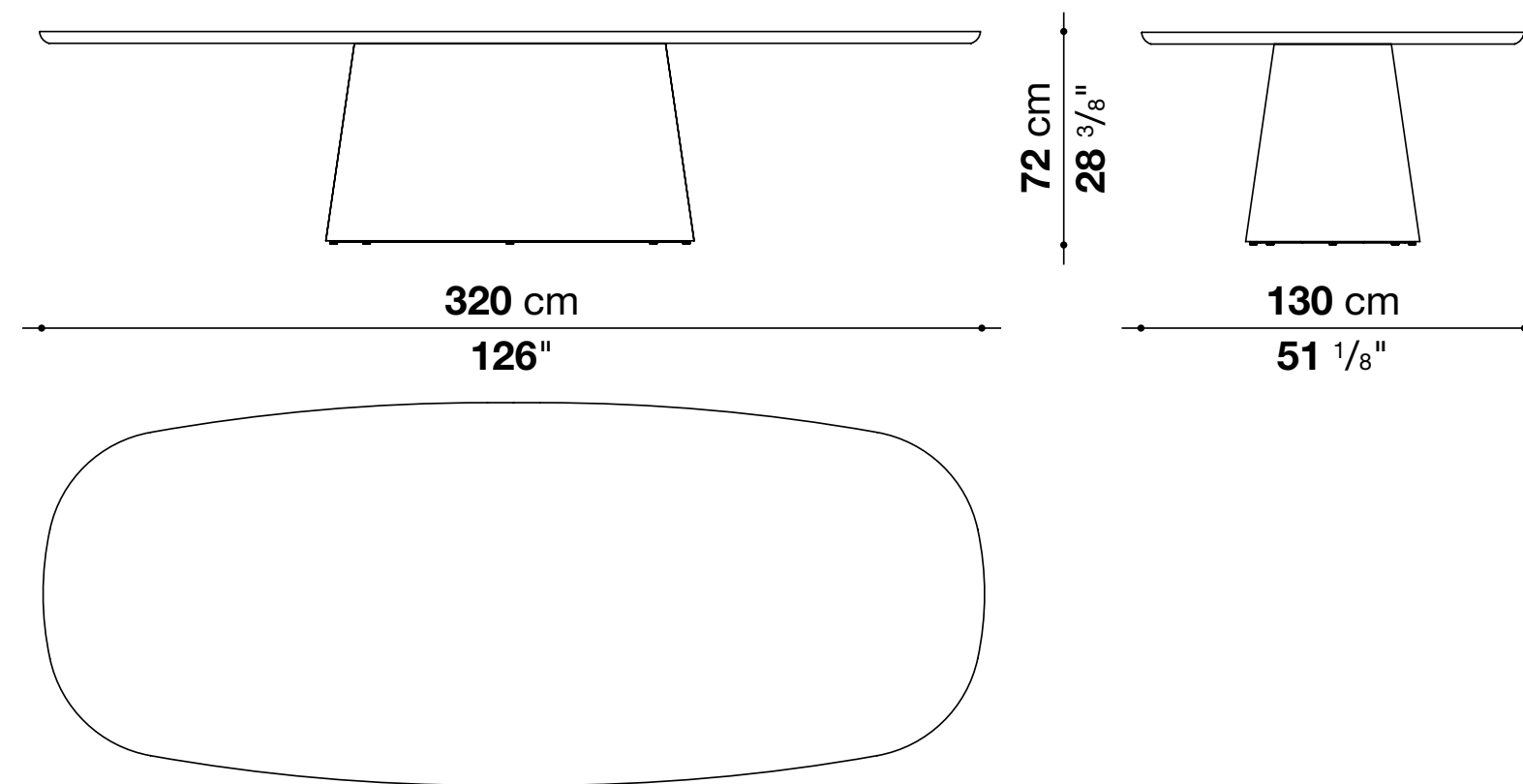

NEW DIMENSION

BASE-FRAME AND TOP
IN SINGLE COLOUR



0374C
brushed light oak



0381N
brushed black oak

BASE-FRAME AND TOP
IN SINGLE OR DOUBLE COLOUR

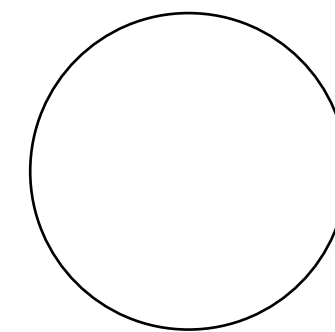

all the range of glossy
lacquered colours

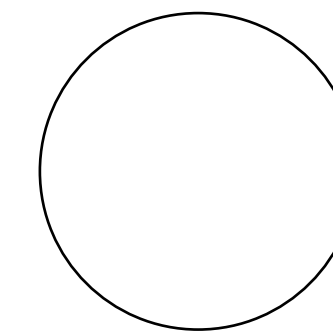

all the range of satin
lacquered colours

—Allure O' Table

design Monica Armani

TAO320_T

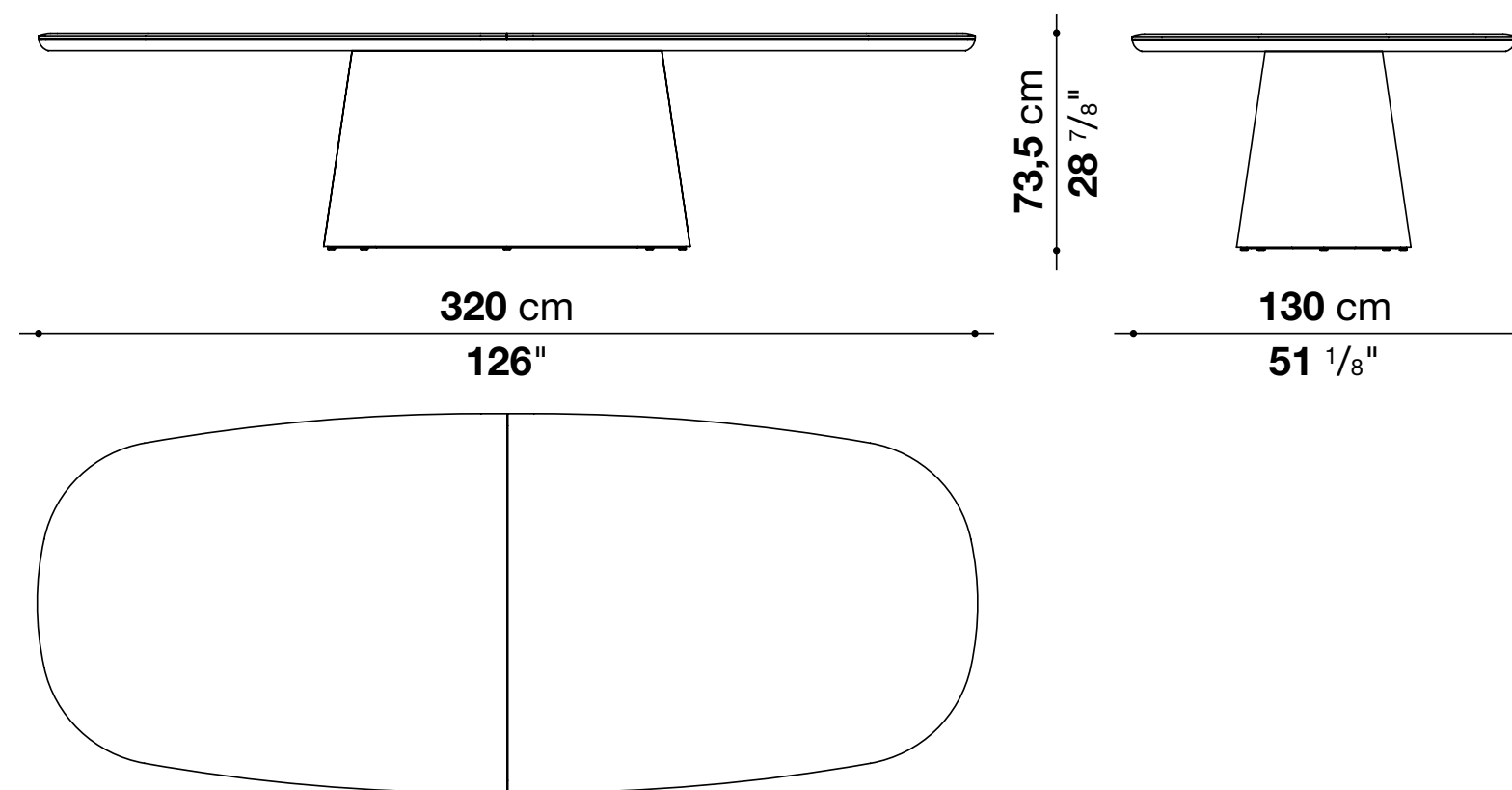

NEW DIMENSION

BASE-FRAME AND LOWER SHELF



0374C
brushed light oak



0381N
brushed black oak

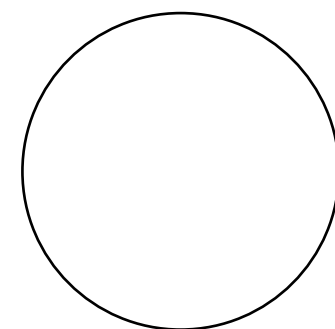

all the range of glossy
lacquered colours

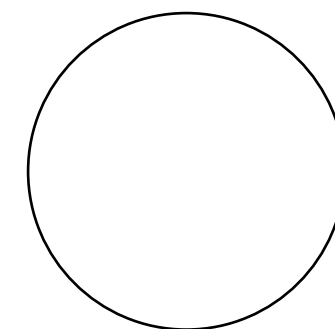

all the range of satin
lacquered colours

TOP

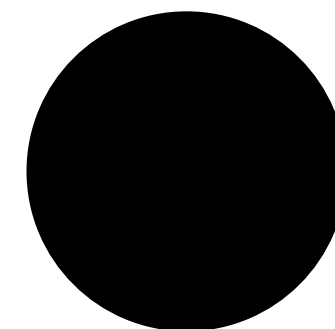

0131N
black smoky glass



0890M
matt Carrara white marble
"venatino statuarietto"



0185P
glossy Marquina
black marble



—Tobi-Ishi, design Barber & Osgerby

Tobi-Ishi is more than a decade old, but the series never ceases to amaze and charm the most demanding audience. The object has also become a true icon of international design thanks to its countless variations. The table retains the strongly sculptural nature defined by the three elements that compose it, inspired by the 'flying stones' that dot the pools of water in Japanese gardens.

This particular balance of solidity and lightness reappears in the new edition characterised by a 313 cm super-size in glossy or satin lacquer, previously only available in wood. A perfect solution to create warmth and intimacy, but also to add a touch of colour to domestic environments thanks to the different shades offered.

—Tobi-Ishi Table

design Barber & Osgerby

The new edition is characterized by a super size of 313 cm in glossy or satin lacquer, previously available only in wood.



—Tobi-Ishi Table

design Barber & Osgerby

T313R

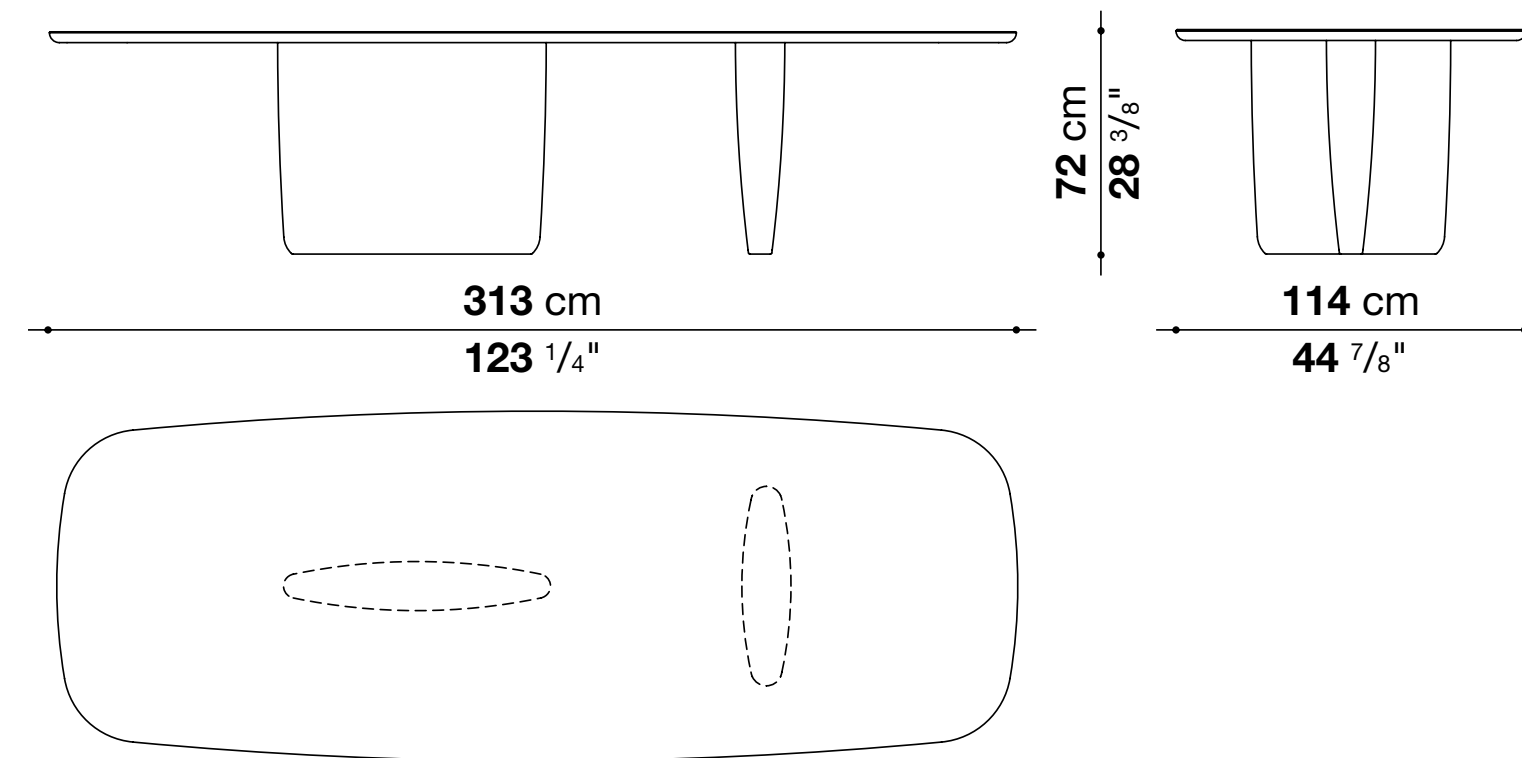

NEW FINISHES 2023

TOP AND LEGS

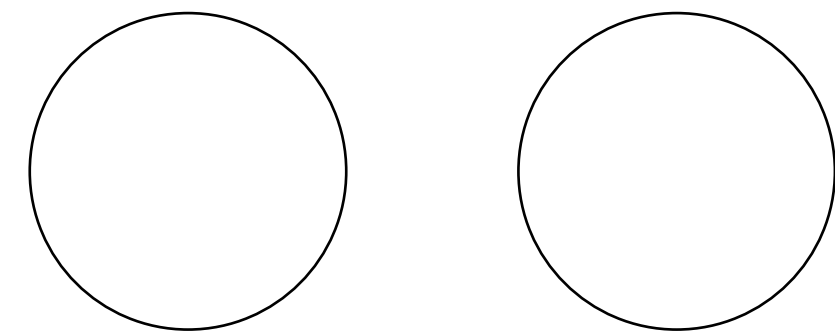

all the range of glossy
lacquered colours
(including candy red)

all the range of satin
lacquered colours



—Alys 10, design Gabriele & Oscar Buratti

"The idea of Alys 10 is to have a base that is more prominent and more present within space, a bed frame with a soft, rounded shape, covered in leather. The characteristic headboard, a leather sheet that, 'pinched' at the base, takes on its natural curved shape, is now enriched by the colour contrast of the stitching."

— Gabriele & Oscar Buratti



10 years after the presentation of the bed Alys, designers Gabriele and Oscar Buratti celebrate the anniversary with a new version to accompany the original. Alys 10 has been envisioned with a more prominent base and soft shapes while maintaining the iconic headboard, made up of a sheet of leather 'pinched' at the base.

The lower band is offered in a medium size to accommodate different types of bed bases. Two sets of feet allow for two different bed platform heights. The proportions change, but the bed keeps its discretion, elegance, and sophistication. Alys 10 also sees the introduction of a refined shade of milk white leather with contrasting stitching.

—Alys 10 Bed

design Gabriele & Oscar Buratti

[back to Products index](#)

[back to Range Extensions 2023 chapter beginning](#)



B&B
ITALIA

—Alys Bed

design Gabriele & Oscar Buratti

- New milky white leather with contrast stitching
- New lower band of medium size
- Two sets of feet for two different bed heights
- More important base and softer shapes



Alys Bed

design Gabriele & Oscar Buratti

LAL

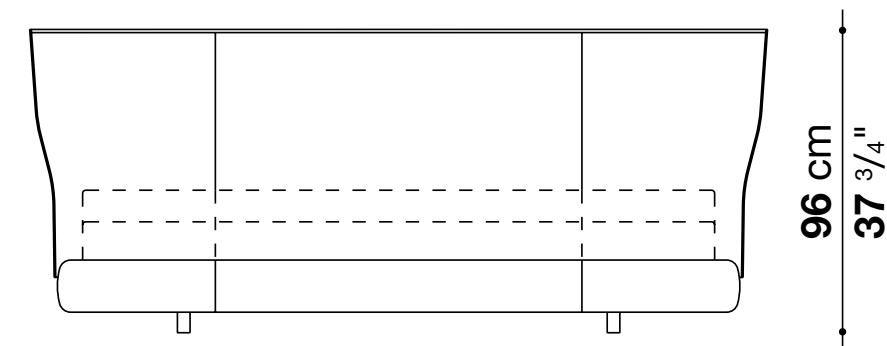

173 - 180 - 200 - 213 - 220 cm
68 1/8" - 70 7/8" - 78 3/4" - 83 7/8" - 86 5/8"

188 - 195 - 215 - 228 - 235 cm
74" - 76 3/4" - 84 5/8" - 89 3/4" - 92 1/2"

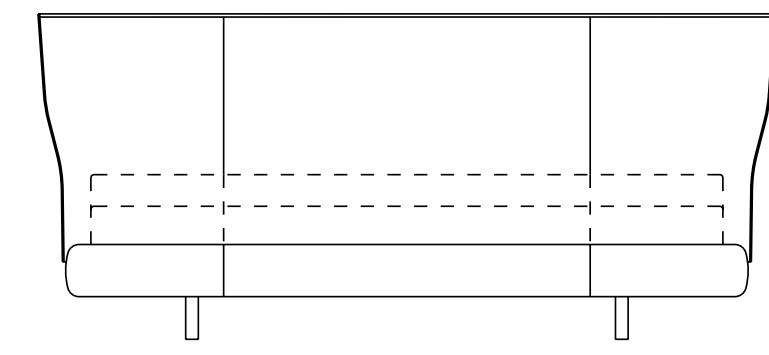

173 - 180 - 200 - 213 - 220 cm
68 1/8" - 70 7/8" - 78 3/4" - 83 7/8" - 86 5/8"

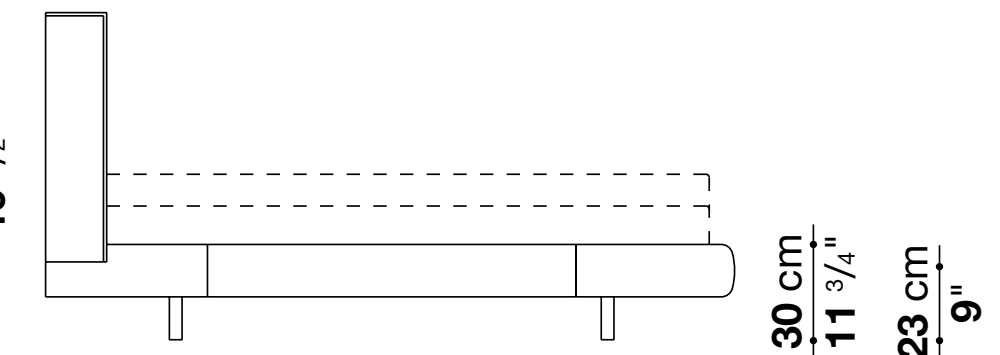

217 - 220 cm
85 3/8" - 86 5/8"

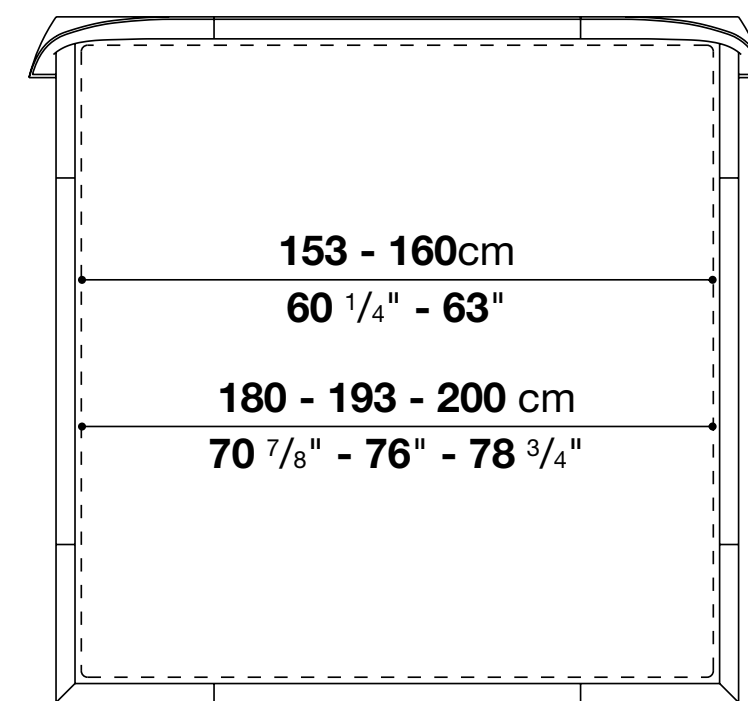

NEW DIMENSION

—Alys Bed

design Gabriele & Oscar Buratti

SMOOTH THICK LEATHER COVER

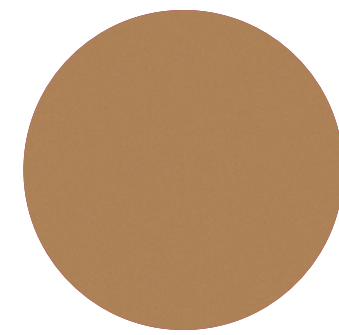

1121300
natural

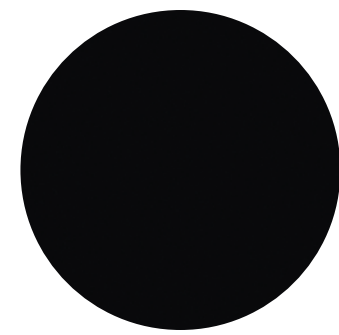

1121150
black

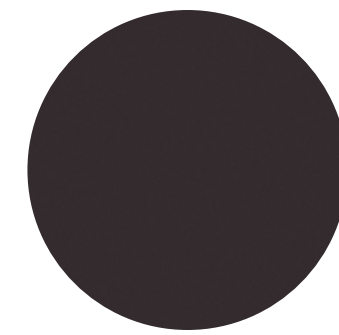

1121350
dark brown

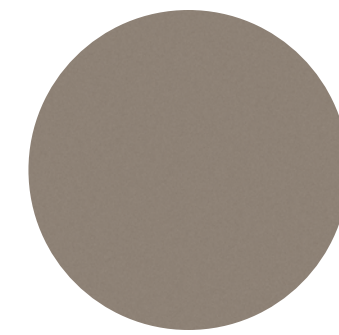

1121280
dove grey

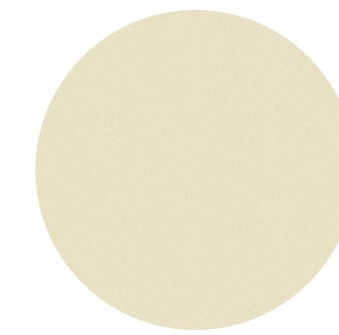

1121201
ivory

STITCHING

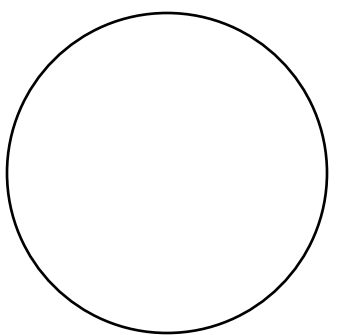

matching tone
stitching

SMOOTH THICK LEATHER COVER



1121104
milk white

STITCHING

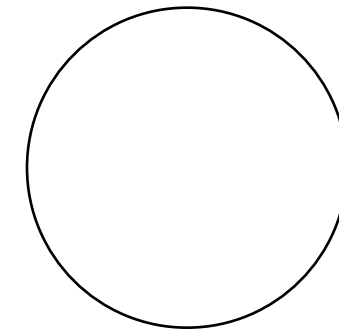

contrast stitching in
dove grey colour

NEW FINISH

EMBOSSED THICK LEATHER COVER



1136100
natural

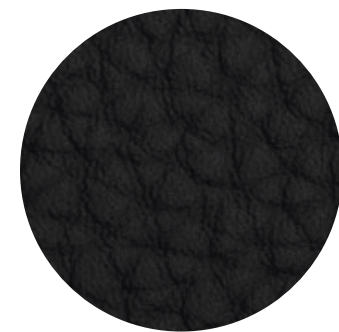

1136150
black



1136350
dark brown



1136750
bordeaux

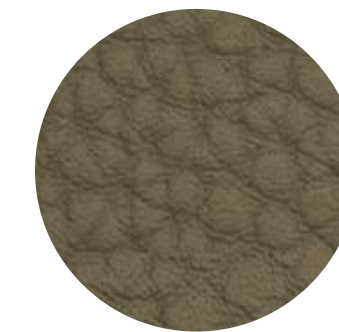

1136420
mud green

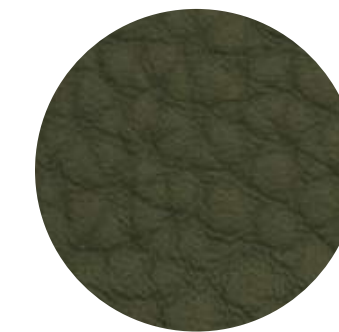

1136400
bottle green

STITCHING

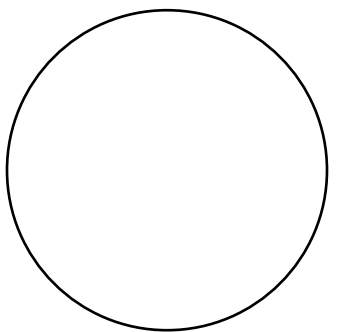

matching tone
stitching

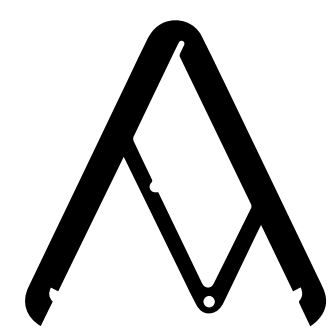

—Serie UP, design Gaetano Pesce Compasso d'Oro Edition

Famous icon of international contemporary design, Serie UP won last June the XXVII Compasso d'Oro "Award for Product Career 2022", the most significant award in the field of Italian industrial design. B&B Italia pays tribute to the anthropomorphic armchair with the limited edition "Compasso d'Oro Edition", available in just 500 pieces.

Up5_6 will be upholstered in the exclusive CD fabric in antique gold, while the spherical ottoman in bronze fabric will be tied to the armchair by means of an aluminum chain with corten finish.

—Serie UP

Compasso d'Oro

design Gaetano Pesce

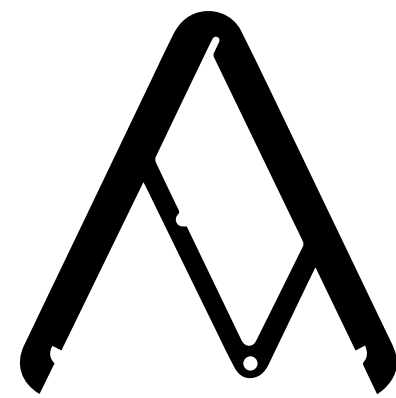

[back to Products index](#)

[back to Range Extensions 2023 chapter beginning](#)



B&B
ITALIA

—Serie UP

Compasso d'Oro

design Gaetano Pesce



[back to Products index](#)

[back to Range Extensions 2023 chapter beginning](#)

B&B
ITALIA

—Serie UP

Compasso d'Oro

design Gaetano Pesce



Limited Edition
500 numbered pieces



—Serie UP

Compasso d'Oro

design Gaetano Pesce

UP5_6CD

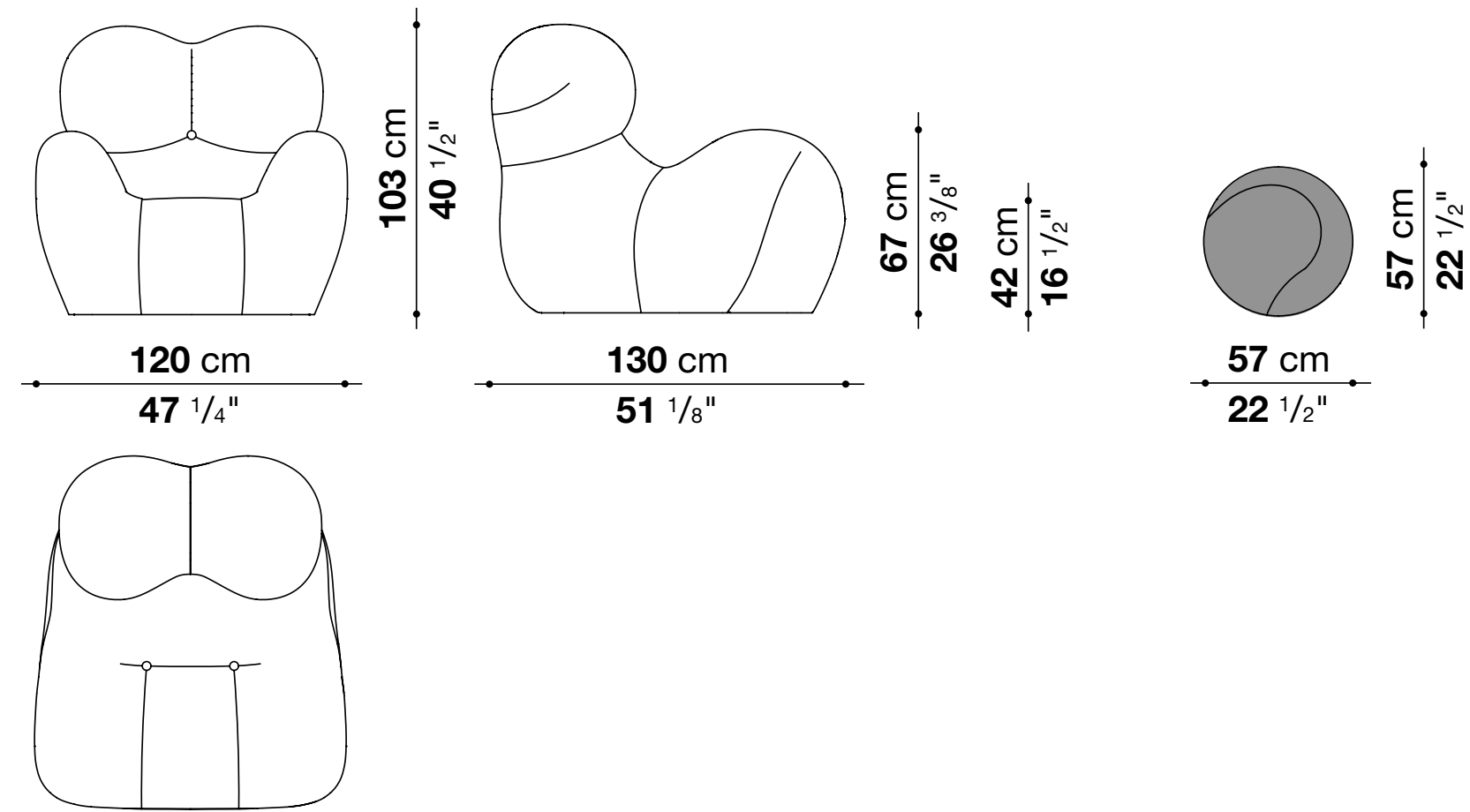

ARMCHAIR COVER



2844560
CD fabric antique gold

OTTOMAN COVER



2844360
CD fabric bronze

—Layout Proposals

—Room

Alys 10

Tortello

Quiet Lines

Planck small table
Glossy dove grey 3738L,
etched glass 0247A

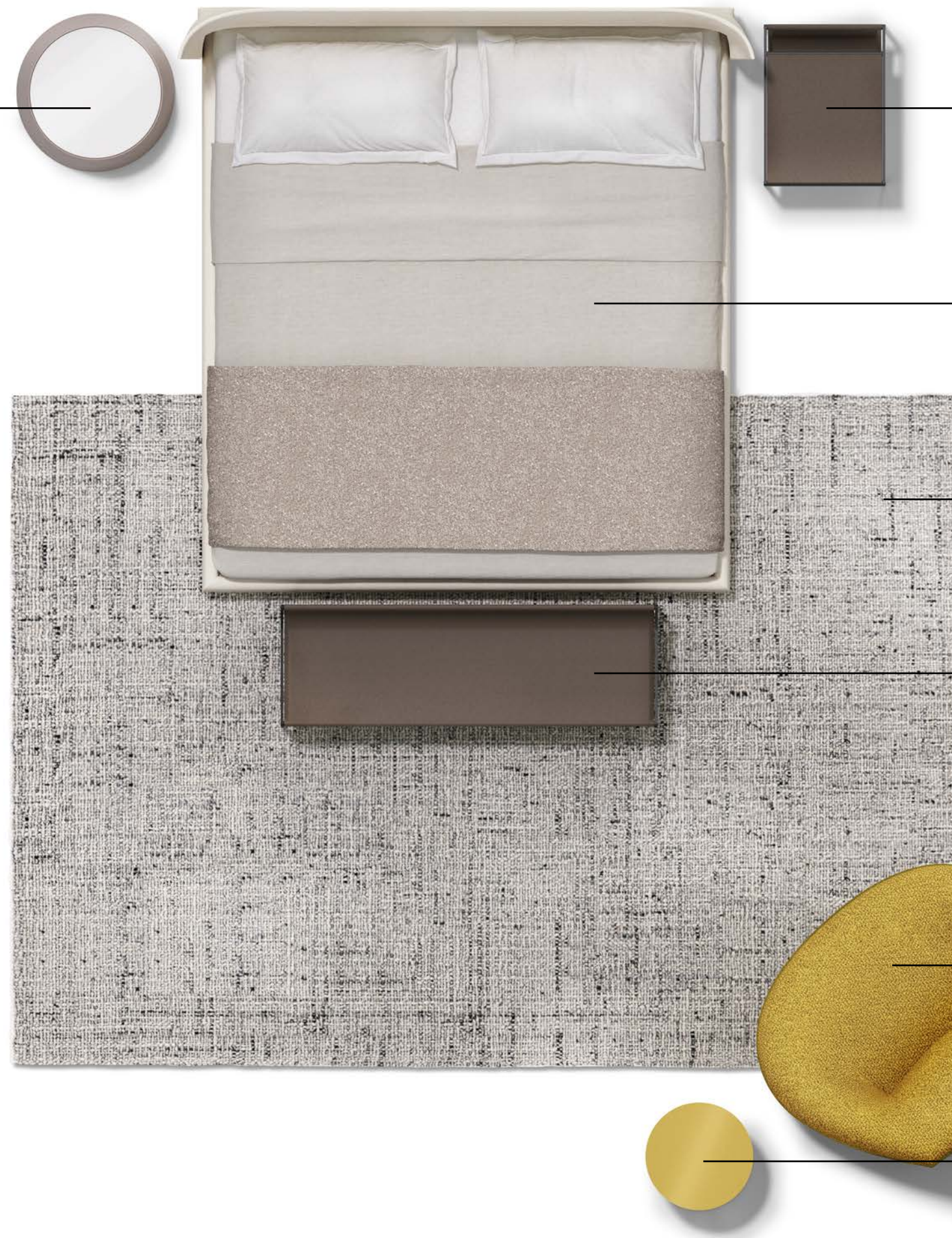

Quiet Lines night table
Gamma 1226256,
transparent extra light glass 0200T,
bronzed nickel painted 0174B

Alys 10 bed
Milk white thick leather 1121104
(dove grey stitchings)

Milos carpet
Graphite 0217G

Quiet Lines bench
Gamma 1226256,
bronzed nickel painted 0174B

Tortello armchair
Lissy 2840500

Spool small table
Glossy mustard 1263L

—Room

Dambo

Tortello

Lemante

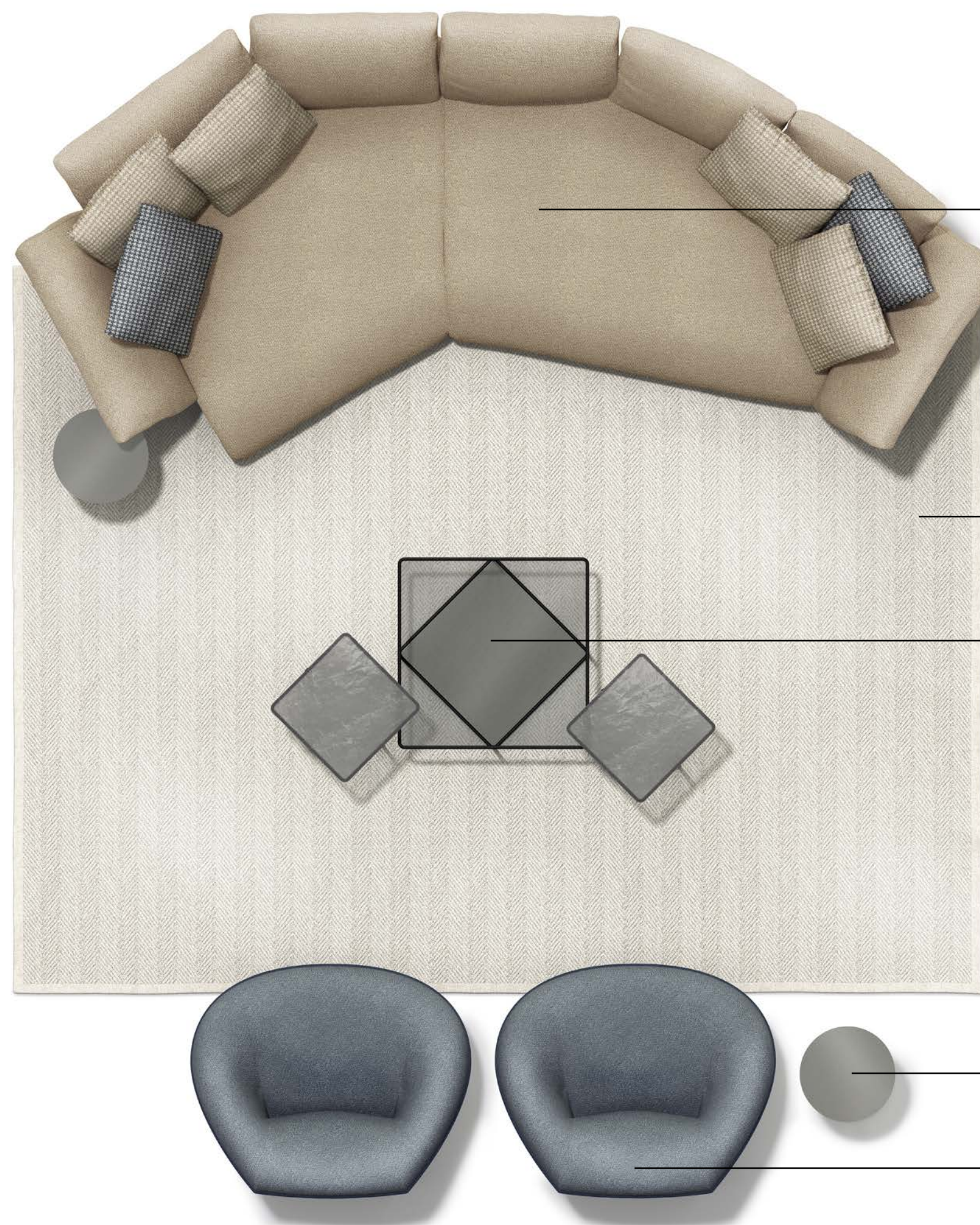

Dambo sofa
Lissy 2840207, bronzed nickel painted 0174B
cushion 55x55 Lagos 2839207
cushion 55x55 Lagos 2839810

Auris carpet
White 0009W

Lemante small tables
LEM45 Quartz grey molten glass 0836B,
matt black painted 0168N

LEM65_E Transparent extra light glass 0200T,
glossy smoke grey 3748L,
matt black painted 0168N

Spool small table
Glossy grey 3748L

Tortello armchair
Lissy 2840810

—Room

Allure O'
Heri O'
Tetrami



Tetrami storage unit
Brushed light ash 0421C

Allure O' table
Glossy milk white stoneware 0851B,
glossy chalk white 9118L

Heri O' chair
Lissy 2840100, glossy clay 7850L

—Marketing & Communication

—Products Delivery Terms

| | | |
|------------------|---------|------------------|
| Tetrami | W 28/23 | July, 10th |
| Lemante | W 30/23 | July, 24th |
| Flair O' Couture | W 30/23 | July, 24th |
| Tortello | W 37/23 | September, 11th |
| Tobi-Ishi | W 37/23 | September, 11th |
| Allure O' indoor | W 37/23 | September, 11th |
| Eryt | W 37/23 | September, 11th |
| Heri O' | W 37/23 | September, 11th |
| Dambo | W 39/23 | End of September |
| Alys 10 | W 43/23 | End of October |
| Quiet Lines | W 44/23 | End of October |



—Delivery Terms

**B&B Italia
Fabric Samples
Agents, Sales Team, DOS**

**New shades April
W 16/23 April 17th**

**B&B Italia
Sampling Hangers Update
All Dealers**

**New shades April
W 23/23 June 5th**

—Collection Experience

in-store tool to generate an immersive
experience through QR Code



—Digital Push

from beginning of April on Pinterest,
Meta traffic and Search Google
present the news 2023 worldwide

from April 18th to 30th Drive to
Milan Store campaign on Meta and
a GDN campaign with visibility and
coverage as main goal

—Webinar Mid May TBC

[back to General Index](#)

W17
24-30 Apr



W16
17-23 Apr

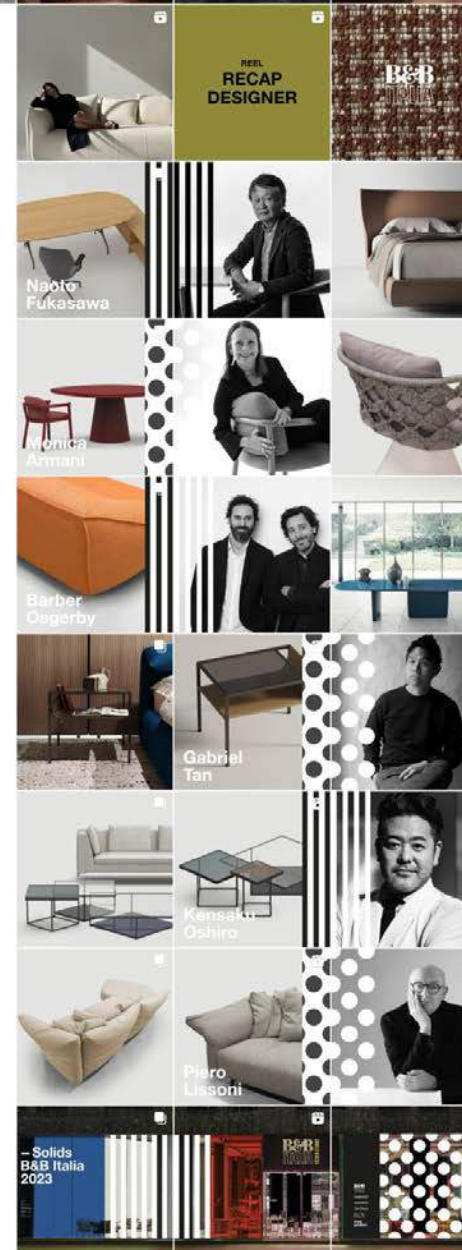

W15
10-16 Apr

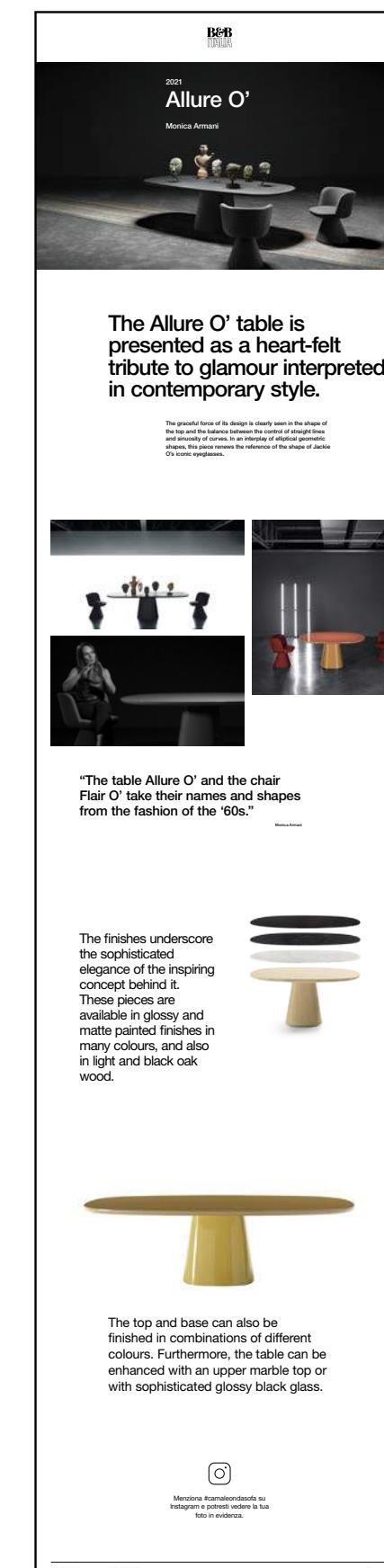



— PR & Press

Secured media coverage
in prestigious Italia and
International magazines.

**NY Times Newspaper
Style & Design Section**
April 13th

Door, La Repubblica supplement
April 13th

Wallpaper
May issue 2023

Wallpaper.com
April 14th

Corriere della Sera, Dorso Design
April 18th

HTSI Superior Interior, Il Sole 24 Ore
April 19th

MF Newspaper
April 18th

Il Messaggero, Molto Futuro
April 20th

Interni
April 2023

AD Italia
April 2023

Ad-italia.it
April 17th

D Casa, Repubblica supplement
April 29th

—B&B Italia tabloid

distributed during Milano Design Week and delivered to DOS and dealers right after

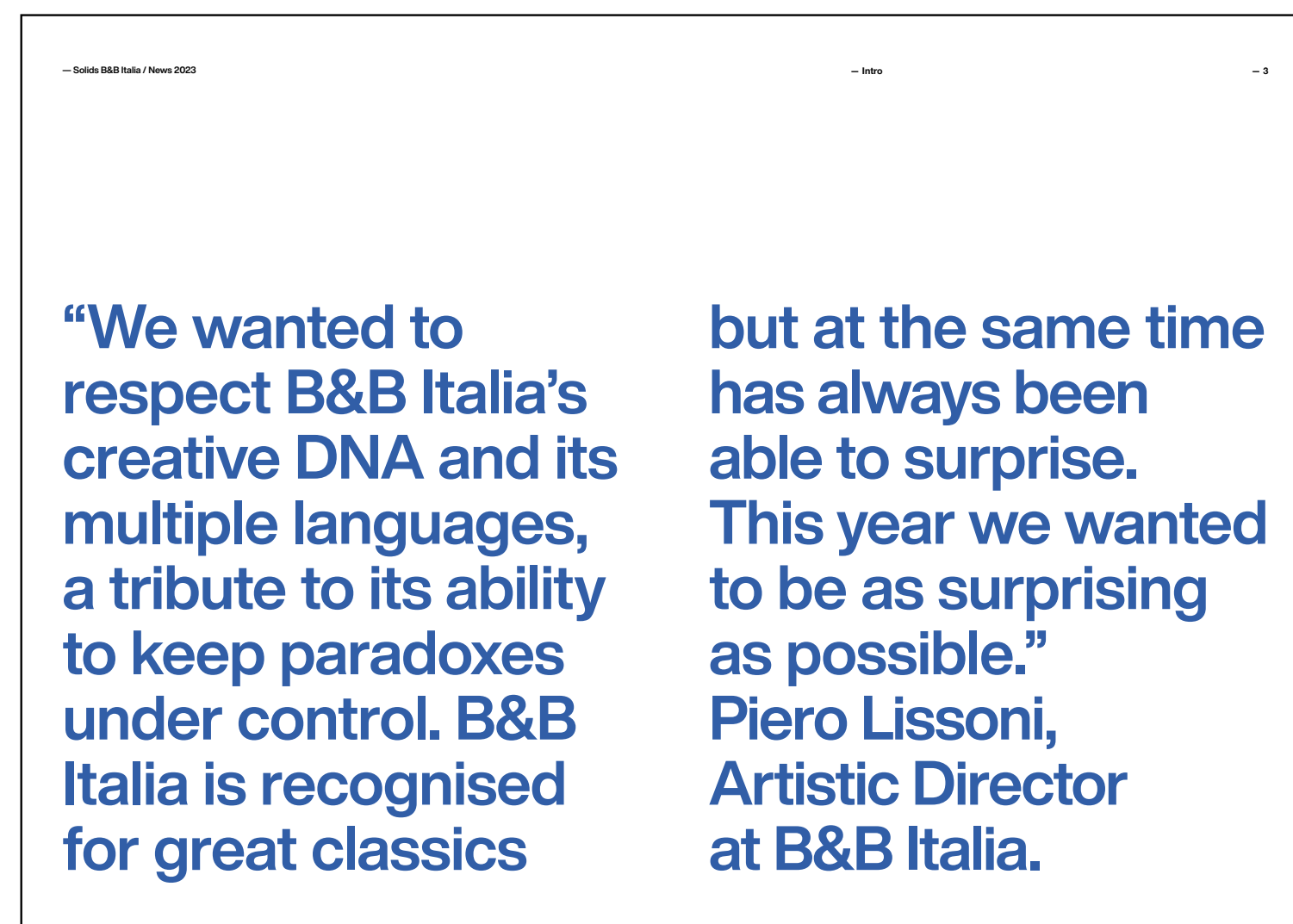

— Event Plan

Milano Design Week AGENDA

Monday 17th April

| | |
|---------------|---|
| 9am-9:30am | PR Meeting in Store |
| 9:30am-2:30pm | Press Preview in Store |
| 12:15am-1pm | Product training to DOS team |
| 3pm-4pm | Marketing & Sales Meeting in Store |
| 4:15pm-5pm | Product Presentation with R&D Team |
| 5pm-5:30pm | Maxalto Meeting with I. Casalino |

Tuesday 18th April

| | |
|----------|---|
| 10am-5pm | Store Opening |
| 5pm-7pm | Closing of the Store for event preparation |
| | No appointments in this time slot |
| 7pm-10pm | In Store Cocktail - by invitation |

Durini Showroom opening hours

Tuesday 18th April

| | |
|----------|---|
| 10am-5pm | Store Opening |
| 5pm-7pm | Closing of the Store for event preparation |

Wednesday 19th April

10am-9pm

Tuesday 20th April

10am-10pm

Friday 21st April

10am-9pm

Saturday 22nd April

10am-9pm

Sunday 23rd April

10am-6pm



— Event Plan

WIFI - upon request for guests in the hospitality area

Wifi: WSaloneDelMobile-BeB

Password: Salone2023B&B

Wardrobe/Cloakroom

Cloakroom service not provided

DRESS CODE

No dress code required – please remember to use the B&B Italia pin you will receive at the reception desk.

Shuttle service– kindly note a transfer service is not available either from Durini to Fiera and backwards.

Photo e video_ no restrictions.

—Thank
you