

la
Parenthèse
de
Lumière

12 JANUARY 2026

MAXALTO

Agenda

INTRODUCTION
NEW PRODUCTS
RANGE EXTENSIONS
MAXALTO RETAIL IDENTITY AND LAYOUT PROPOSALS
MARKETING AND COMMUNICATION

LA PARENTHÈSE DE LUMIÈRE

The Maxalto 2026 collection unfolds as a suspended interval, a rarefied pause that gently interrupts the narrative flow to reveal a new radiance. It is a fragment of light within the Ville Lumière for Maison & Objet 2026, a delicate moment of suspension in the evolution of the collection, marked by new designs and range extensions in which forms, materials and details emerge with renewed intensity. A light that is both metaphorical and tangible, illuminating the identity of the furnishings and finding resonance in the brilliance of the new sideboards, symbols of a moment of renewed optimism and refined design expression.



“For this new dining proposal, my focus was primarily on materials. The new Luminor storage units in PVD are compact volumes in yellow or rose gold, enclosed by a glass top: autonomous presences that do not seek camouflage, but instead engage in dialogue with any setting, whether classic or contemporary. The Kalystrus tables, crafted entirely in marble, share this same radical approach: tops supported by solid elements, like columns, that become fixed points in space, independent of the character of the surrounding interior.”

Antonio Citterio

NEW PRODUCTS

Luminor

Luminor

Luminor is a new collection of storage units that combines design rigour, precious materials and advanced technologies, giving rise to a family of elements with a strong architectural identity. The range comprises three types of units: one vertical version, 135 cm high and 95 cm wide, available with or without integrated lighting, and two horizontal versions offered in heights of 78 cm and 55 cm. The former is ideal as a service element in dialogue with the dining table, while the latter is designed for the living area and is perfectly proportioned to sit opposite a sofa. Both horizontal versions measure 220 cm in width.

From Lūmen, referring to the brightness of the surface.



Luminor

Luminor introduces the use of PVD - a technology already developed by Arclinea for its high-end kitchens - in yellow gold or rose gold finishes. The project is the result of the encounter between the technical expertise of Antonio Citterio, Art Director of both Maxalto and Arclinea, and the industrial know-how developed by Arclinea, coherently translated into the aesthetic and quality standards of Maxalto.

Luminor

PVD stands for Physical Vapor Deposition and is a finishing process, realized inside a closed and vacuumed space, where metals like titanium, zirconia or chrome are vaporized on a steel sheet to adhere on the surface in a durable way. This allows a long lasting, shiny and mirror like reflecting finishing. PVD offers a more durable and environmentally safe finishing as there is nearly no use of chemicals or material waste.

Luminor

Maintenance:

Use a soft cloth: Microfiber is ideal to avoid scratches.

Mild cleaning solution: Use lukewarm water or a gentle, pH-neutral detergent.

Avoid harsh chemicals: Do not use abrasive cleaners, strong acids, bleach, or solvents like acetone.

Rinse and dry: After cleaning, rinse with clean water and gently dry with a soft cloth.

For stubborn dirt: Use isopropyl alcohol (IPA) diluted in water sparingly, then rinse thoroughly



220 x 56 x h. 78 cm
86 5/8" x 22" x h. 30 3/4"



220 x 56 x h. 55 cm
86 5/8" x 22" x h. 21 5/8"

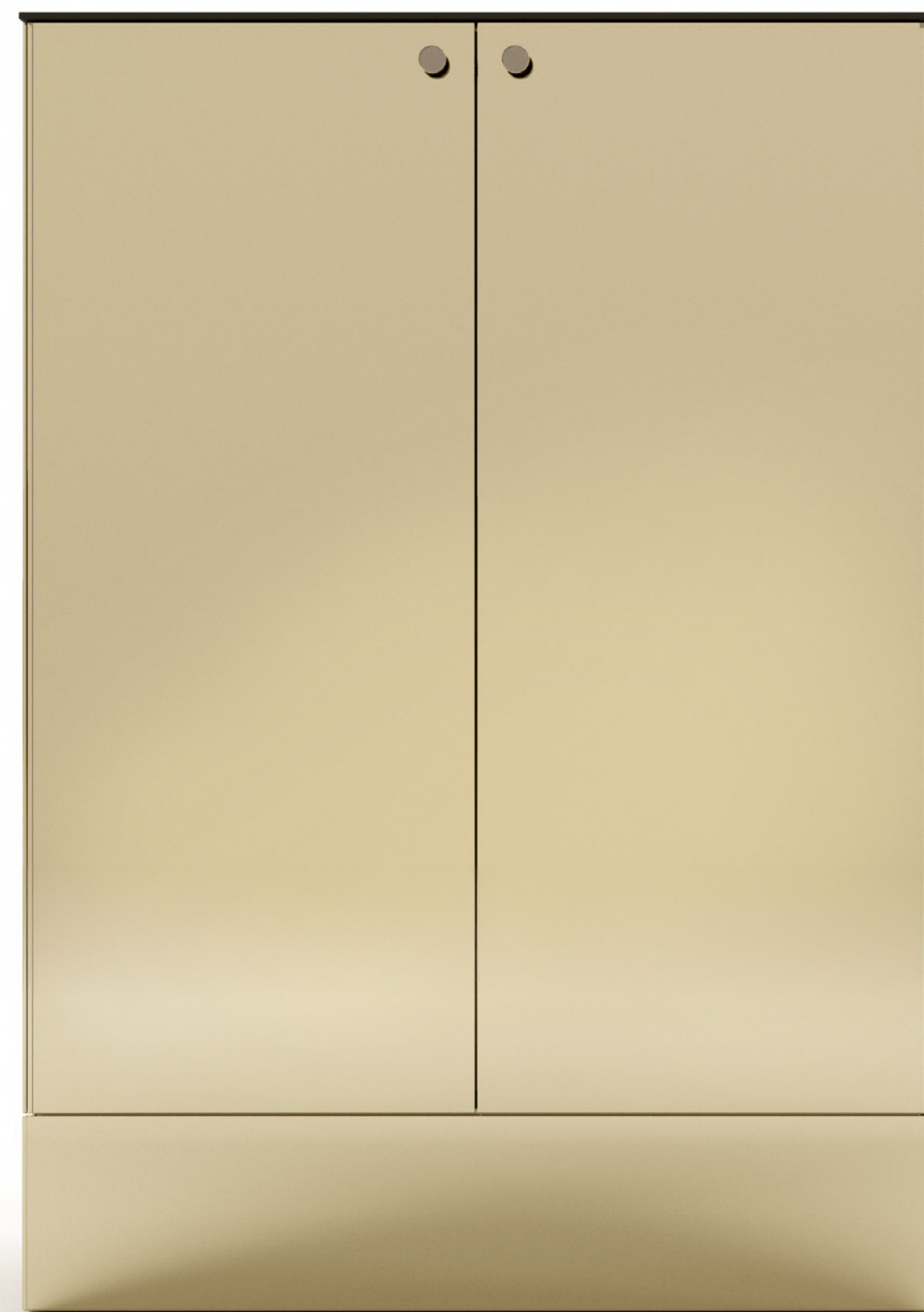

95 x 46 x h. 135 cm
37 3/8" x 18 1/8" x h. 53 1/8"

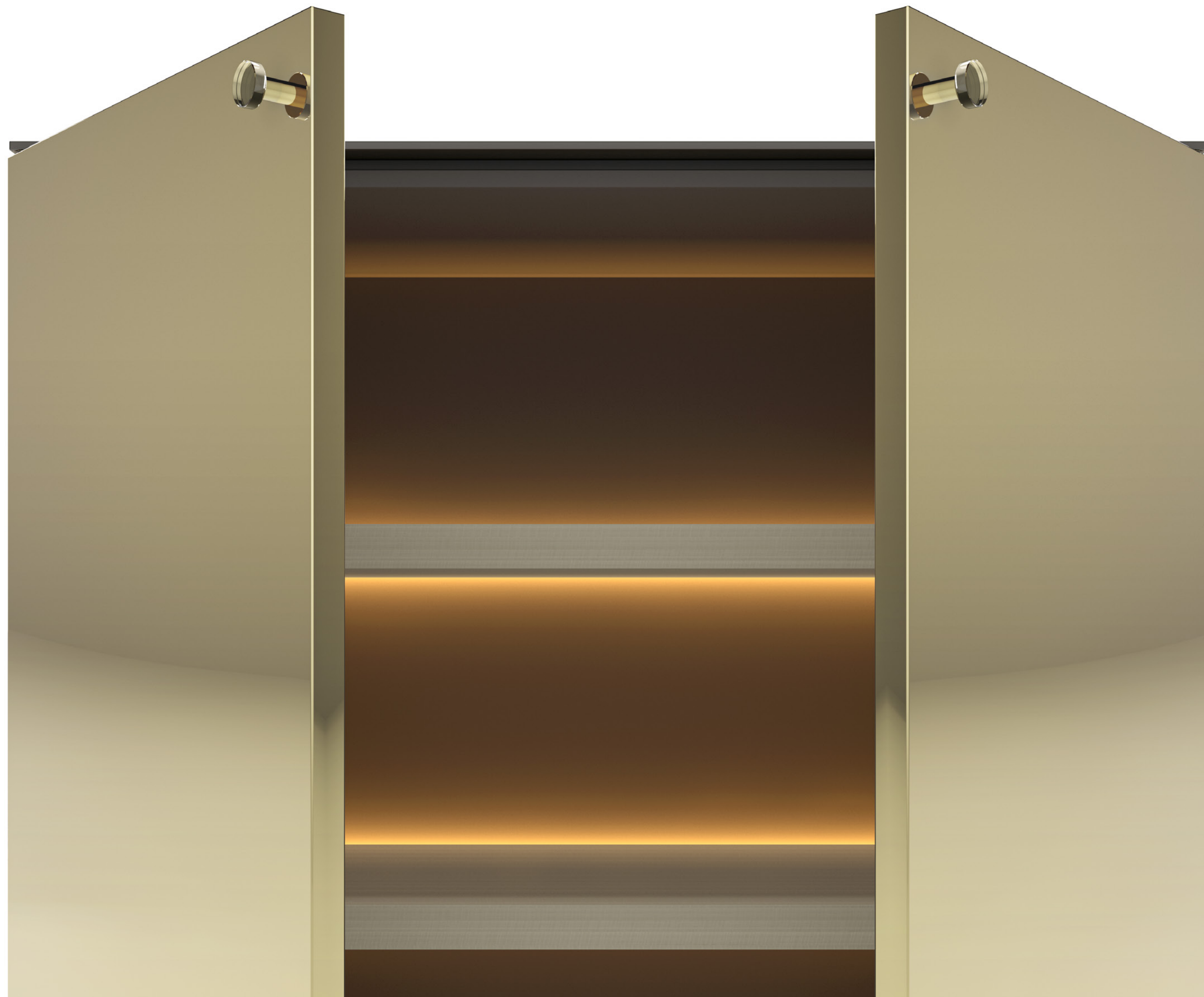

Luminor

The Luminor volumes feature hinged doors and drawers. The interiors, conceived as refined cases, are finished in elegant taupe tones and equipped with internal fittings in maple frisé, enhancing the sense of sophistication. The bronzed reflective painted glass top adds further refinement and harmonises with the knob handle, simple in form yet exquisitely detailed, also made of glass with the same finish as the top.

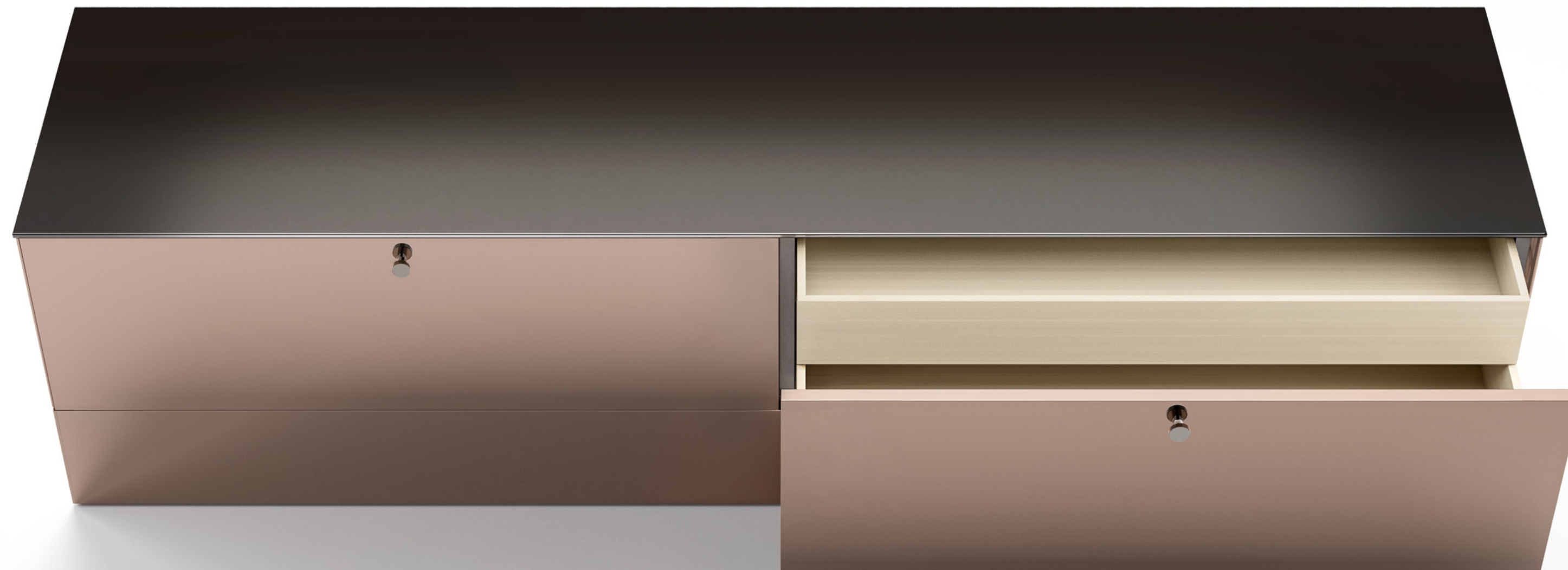

220 x 56 x h. 55 cm
86 5/8" x 22" x h. 21 5/8"

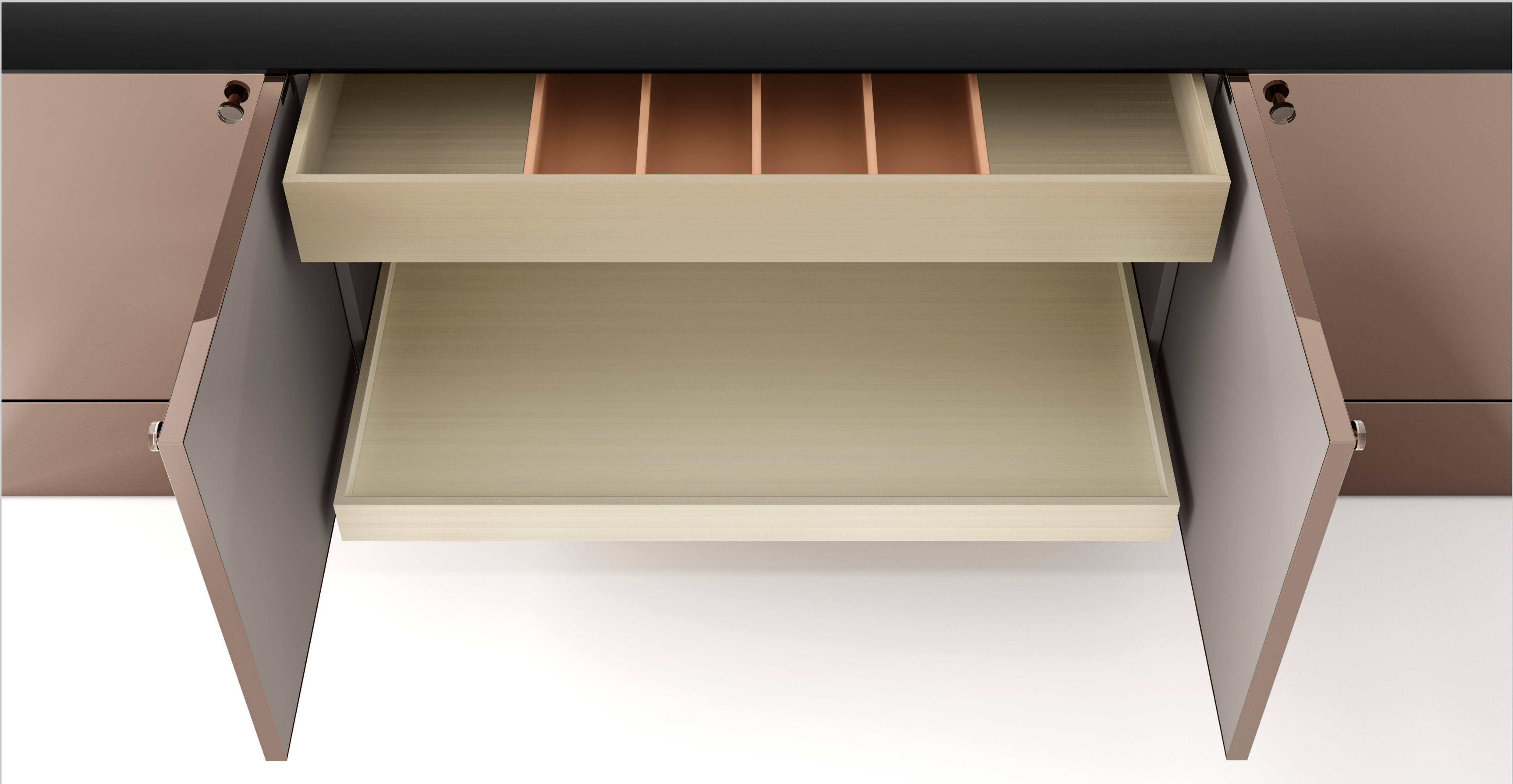

Luminor

The structure is raised from the floor by a substantial 20 cm plinth, visually lightening the volume while lending a sculptural presence to the piece as a whole.

With Luminor, Maxalto inaugurates a new language for living and dining spaces, where technology, preciousness and compositional balance coexist in a perfectly controlled equilibrium.

Technical details

STORAGE UNITS

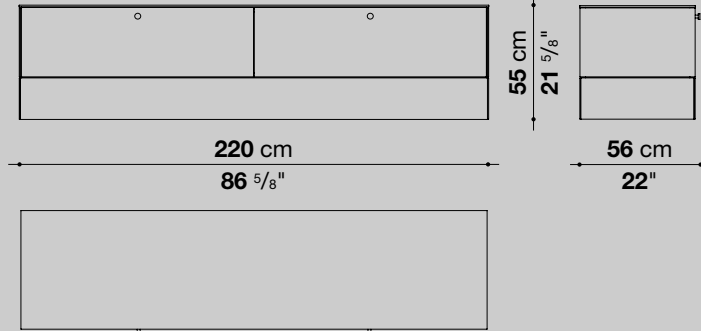

LMR1

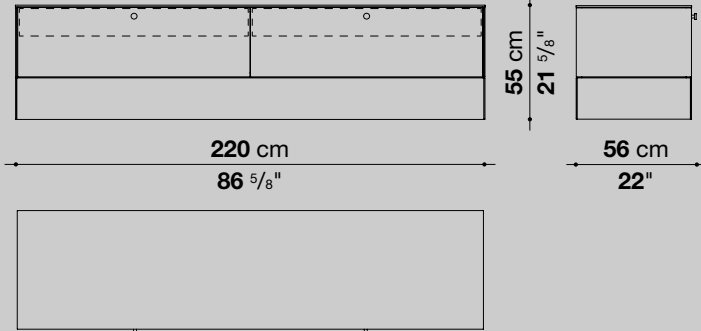

LMR2

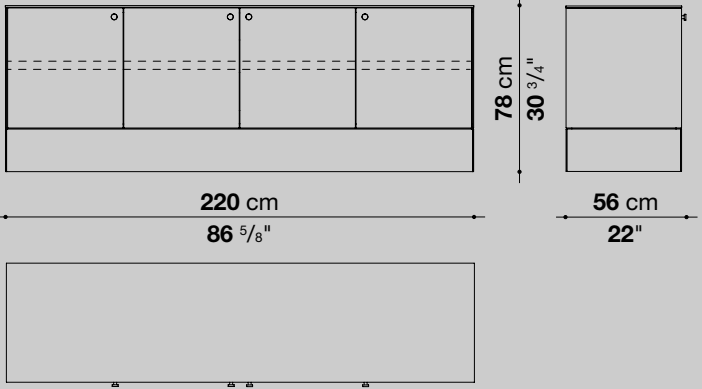

LMR3

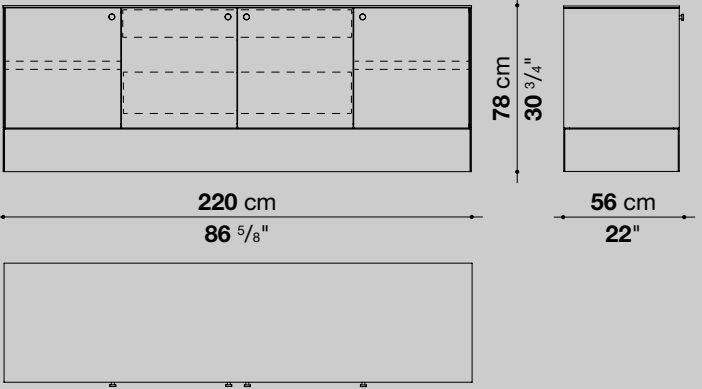

LMR4

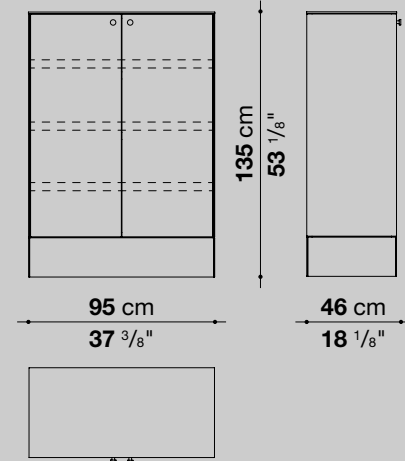

LMR5

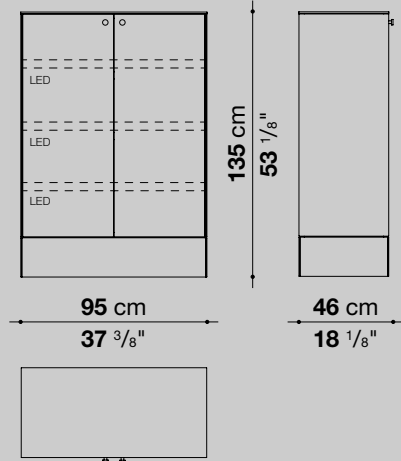

LMR5L

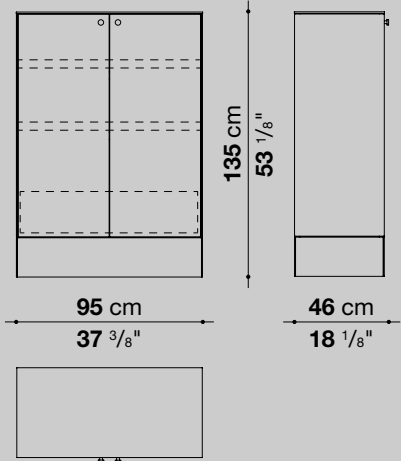

LMR6

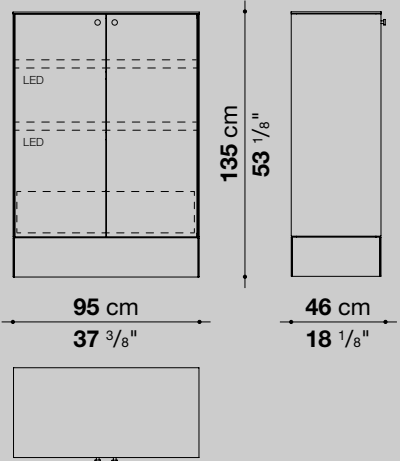

LMR6L

NOTE: ALL ELEMENTS ARE AVAILABLE WITH OR WITHOUT FINISHED BACK

Finishes

External frame

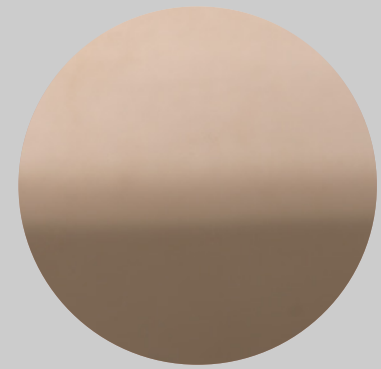

0504R
ROSE GOLD
COLOUR PVD



0652G
YELLOW GOLD
COLOUR PVD

Internal frame

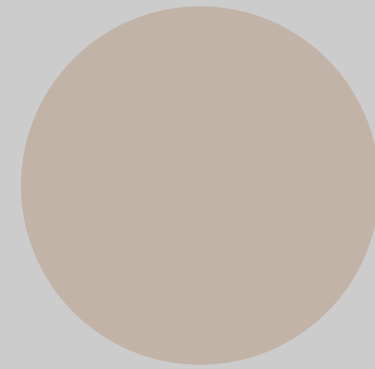

0815T
DOVE GREY
MELAMINE FACED

Upper top and handle

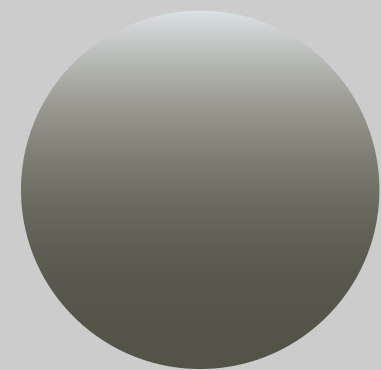

0124R
PAINTED BRONZED
REFLECTIVE GLASS

Shelf, drawer interior and extractable tray

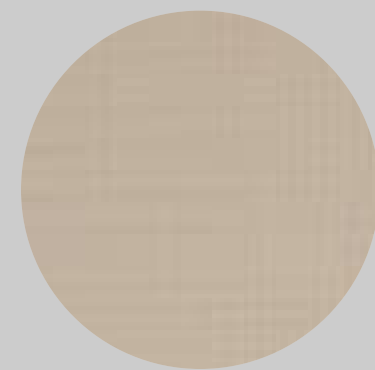

0351A
MAPLE FRISÉ

Kalystrus

Kalustrus

The new Kalustrus table collection explores the theme of monumentality through pure geometries and materials of strong presence. At the heart of the project is the conical form, reinterpreted as a structural element capable of lending the tables a sculptural yet elegant character.

Name of Greek inspiration that mostly recalls the word Kalos = beautiful, from the Greek καλός, and the classical ideal of the “beautiful and good” “καλός κάγαθός” so used in Homeric poems and among philosophers.



300 x 110 x h. 73 cm
118 1/8" x 43 1/4" x h. 28 3/4"



350 x 110 x h. 73 cm
137 3/4" x 43 1/4" x h. 28 3/4"



Ø 160 x h. 73 cm
Ø 63" x h. 28 3/4"

Kalystrus

The elliptical-top version, available in widths of 300 cm and 350 cm, seats 8-10 people and features two conical legs, a solution that enhances both stability and visual strength.

Alongside this is a circular version seating six, a new interpretation of the round table that adopts a single central cone as its base. Offered in one size with a diameter of 160 cm, it provides a convivial solution with balanced proportions. Both versions are available entirely in wood, in a range of finishes - brushed light oak, brushed black oak and wengé - as well as entirely in marble. Marble options include the new polished veined Arabescato, alongside polished white Calacatta and matt or polished black Marquinia, already part of the Maxalto collection.



Ø 160 x h. 73 cm
Ø 63" x h. 28 3/4"

Kalystrus

A further option combines a wooden top with marble legs, expressing a measured balance between material richness and proportion, and establishing a strong architectural presence within the domestic space. In this configuration, the conical base is also available in natural travertine marble. The mineral presence of this element naturally complements the wooden finishes of the top, creating a harmonious contrast between warm surfaces and varied textures.

With this collection, Maxalto expands its formal repertoire, introducing a new language of assertive volumes and noble materials, interpreted through the design sensibility of Antonio Citterio.

Technical details

TABLES

WOODEN VERSION

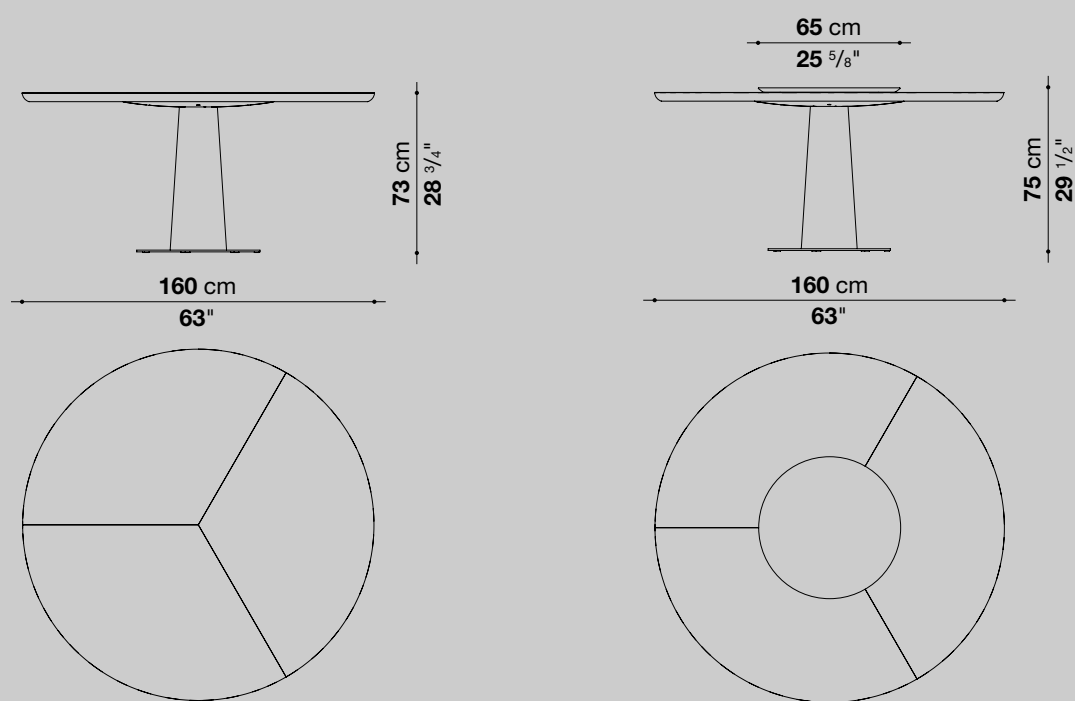

6 SEATS TKL160 TKL160G

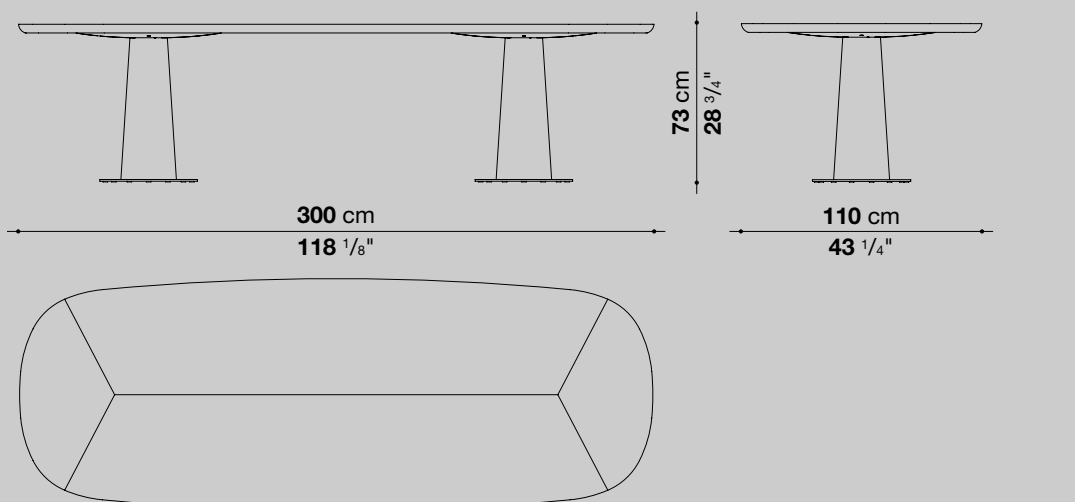

WOODEN TOP+MARBLE LEG VERSION

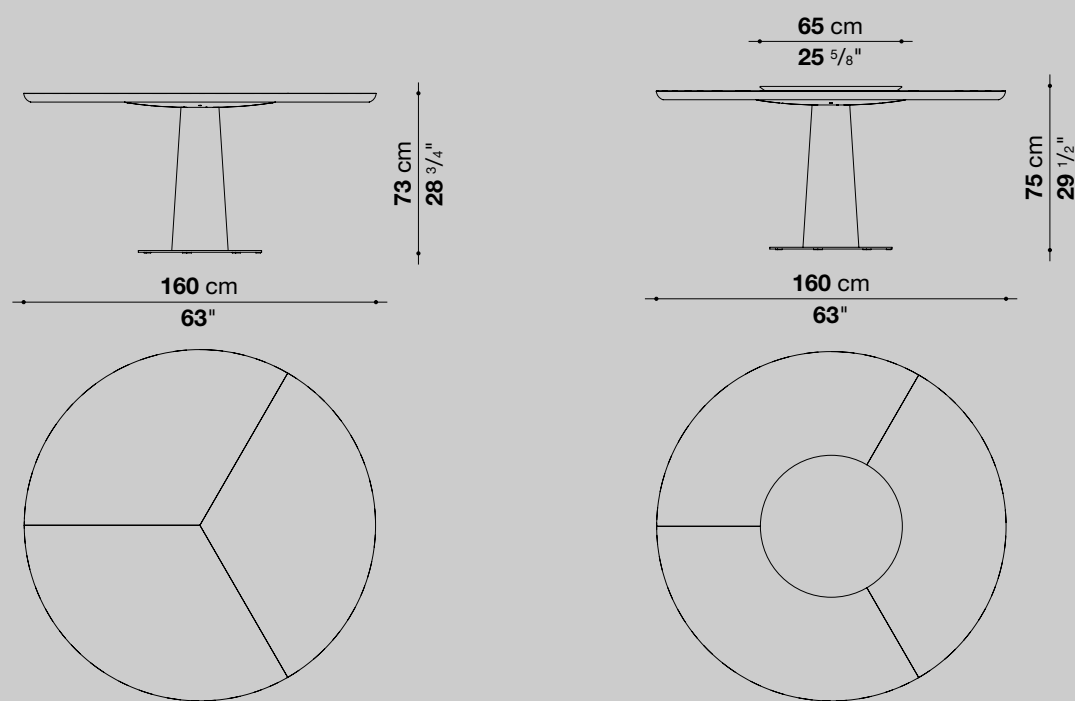

TKL160_MR_MW TKL160G_MR_MW

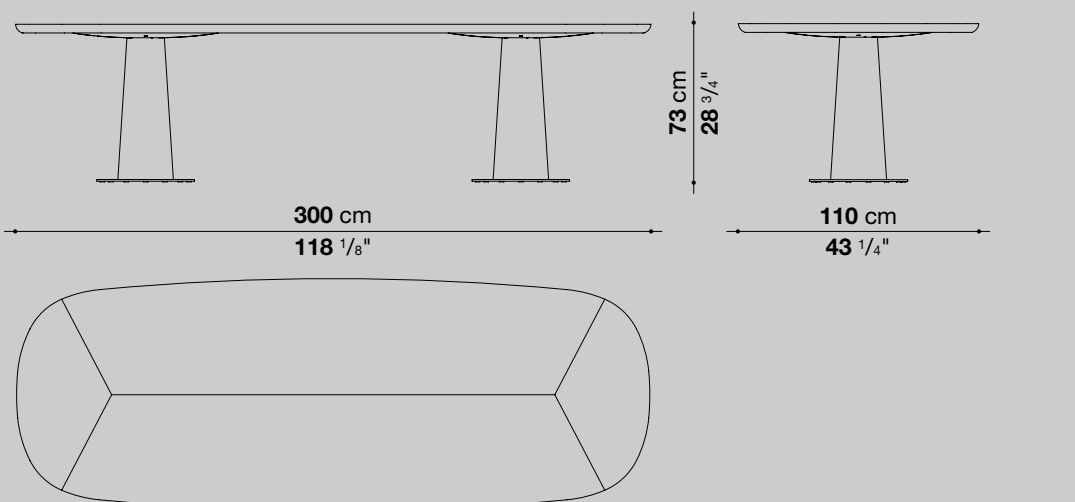

MARBLE VERSION

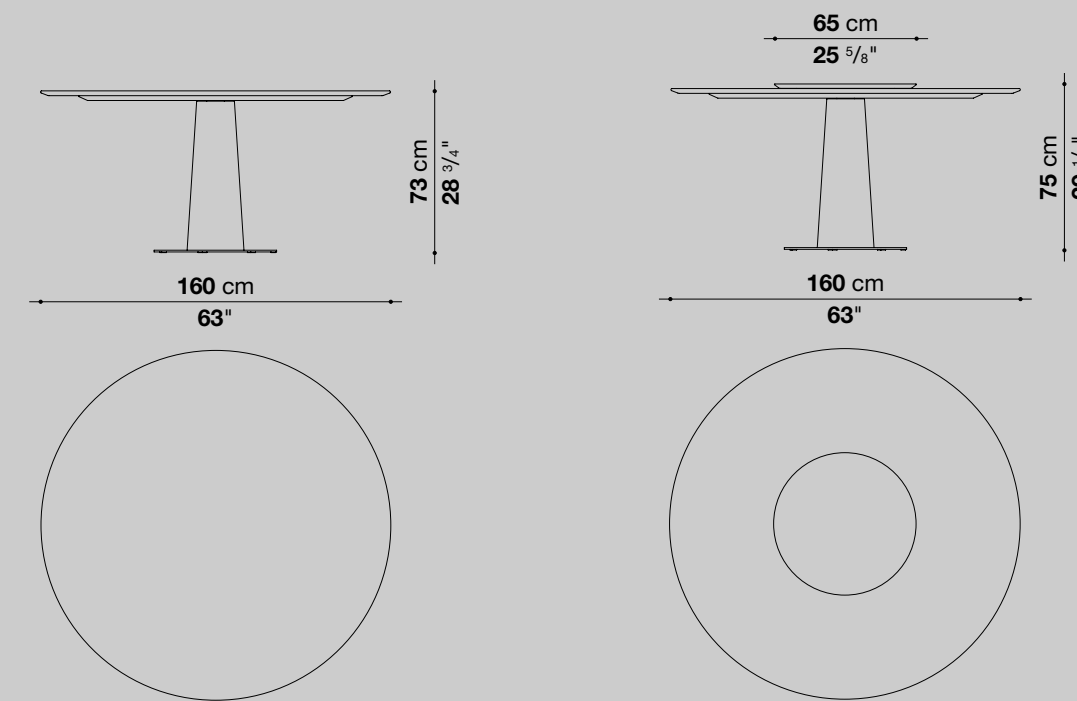

TKL160_M TKL160G_M

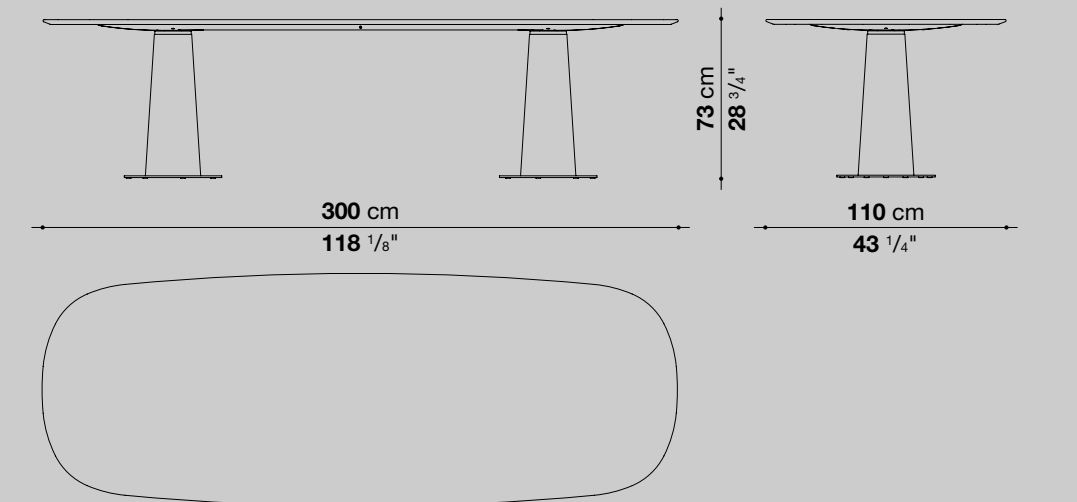

MARBLE TOP+WOODEN LEG VERSION

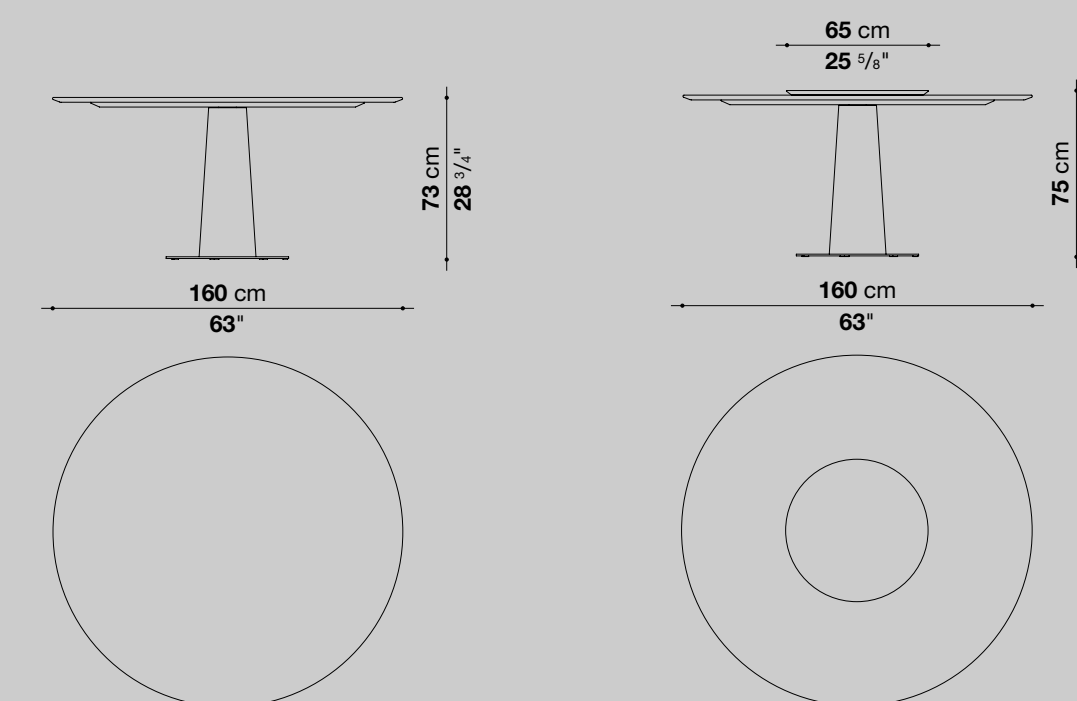

TKL160R_W_M TKL160GR_GW_M

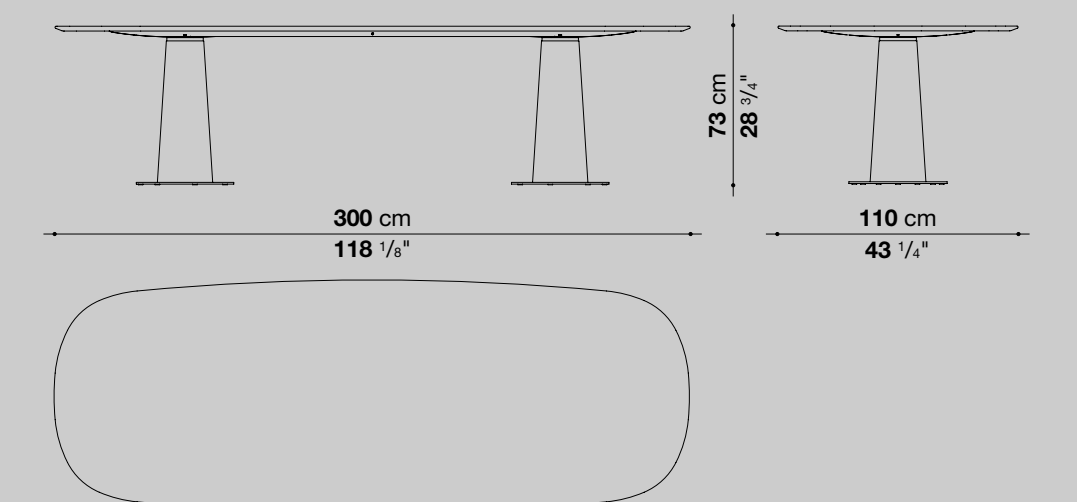

8 SEATS TKL300

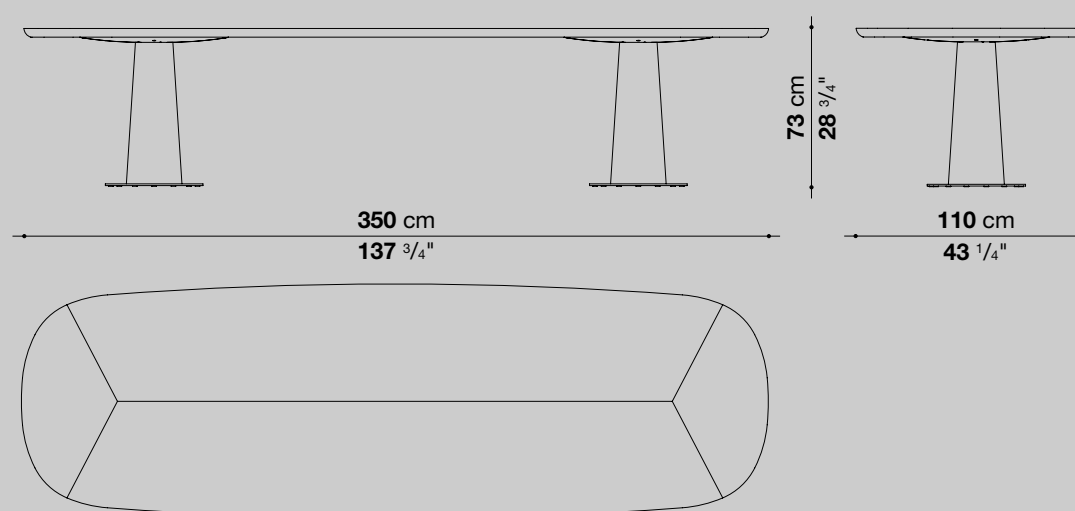

TKL300_MR_MW

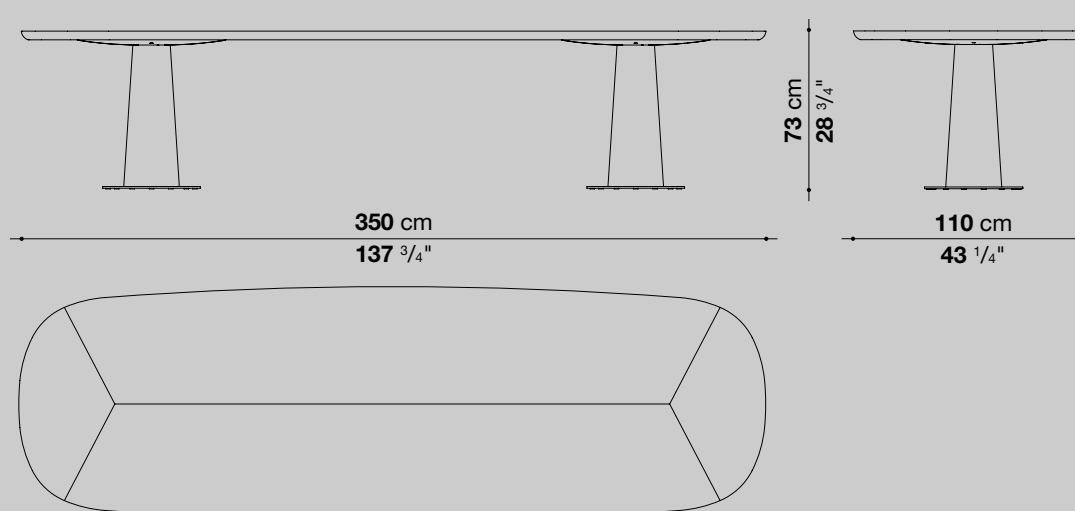

TKL300_M

TKL300R_W_M

10 SEATS TKL350

TKL350_MR

Finishes

Wooden version

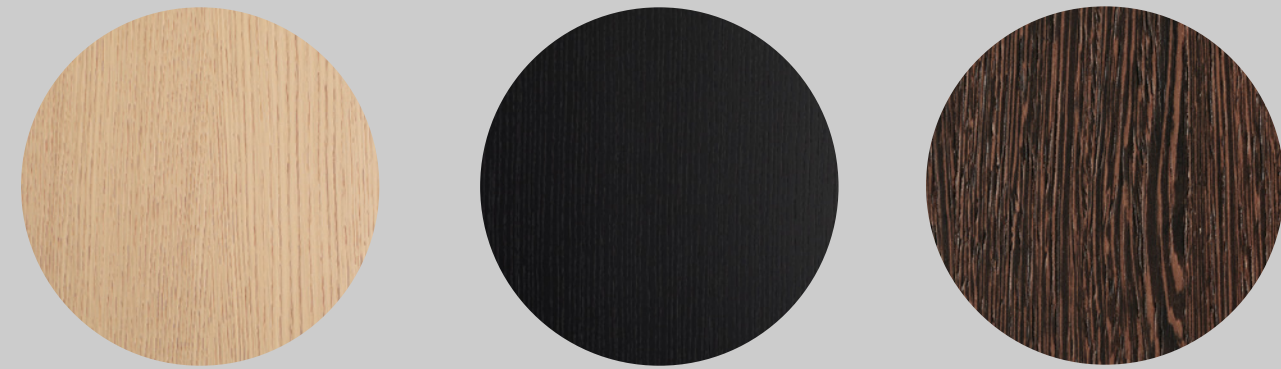

0374C
BRUSHED
LIGHT OAK

0381N
BRUSHED
BLACK OAK

0414W
NATURAL
WENGE

Marble version

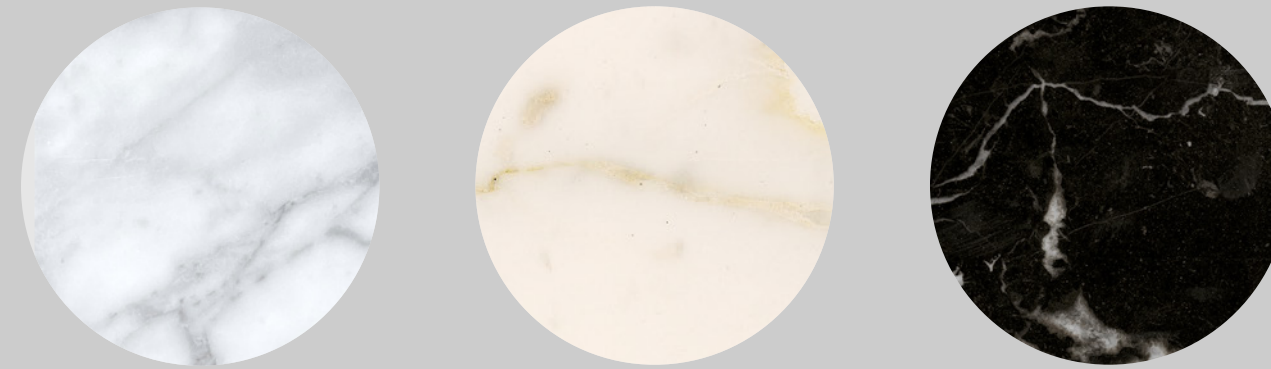

0839A
GLOSSY VEINED
ARABESCATO
MARBLE

0184P
GLOSSY
CALACATTA
WHITE MARBLE

0185P - 0955M
GLOSSY - MATT
MARQUINIA
BLACK MARBLE

Wooden top + marble leg version + swivel tray



0374C
BRUSHED
LIGHT OAK

0381N
BRUSHED
BLACK OAK

0414W
NATURAL
WENGE

0839A
GLOSSY VEINED
ARABESCATO
MARBLE

0184P
GLOSSY
CALACATTA
WHITE MARBLE

0185P - 0955M
GLOSSY - MATT
MARQUINIA
BLACK MARBLE

0188P
NATURAL
TRAVERTINE
MARBLE

Leg base

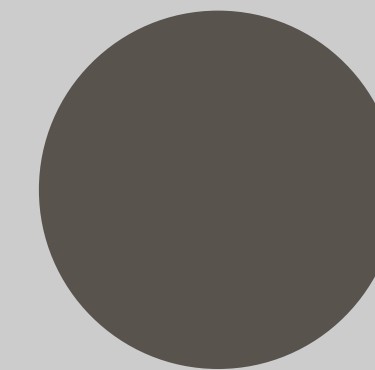

0174B
BRONZED
NICKEL
PAINTED

NOTE: TABLES CM 350 NOT AVAILABLE IN MARBLE AND NATURAL WENGE VERSION

RANGE EXTENSIONS

Artemone

Artemone

The Artemone storage collection was introduced in 2024 from the desire to reinterpret the traditional dining cupboard once associated with the kitchen, transforming it into a contemporary service element dedicated to dining. Today, Antonio Citterio presents a new horizontal configuration with drawers, conceived as a natural extension of the family and designed to harmonise with the proportions of the current dining tables in the collection. Resting on an elegant die-cast aluminium base or in a new floor-standing version, the unit subtly references certain stylistic cues from the 1960s, reinterpreting the combination of hinged doors and a top drawer in an essential yet sophisticated form

Artemone, from the Greek *artémōn*, indicates an element that supports and controls the structure. The name evokes the idea of constructive balance and moderation, where form arises from the project function and clarity.



Artemone

It is available in numerous configurations of doors, drawers and modules with or without flap doors, all of which can be fitted with internal shelves, pull-out trays and cutlery inserts, allowing for a personalised and functional organisation of space. The aluminium base, light in design and separated from the upper section by a narrow shadow gap of just a few millimetres, lends the structure an airy quality and softens the material contrast between metal and wood. The base finishes can be coordinated with the upper section, which is available in black, soya or red lacquer, or in wood finishes including grey oak, brushed light or black oak, and sawn white oak, a tone characterised by a highly tactile texture.

With these new configurations, Artemone further expands its identity, offering an elegant and functional storage unit that integrates seamlessly into contemporary dining environments.



242 x 48 x h. 109 cm
95 1/4" x 18 7/8" x h. 42 7/8"

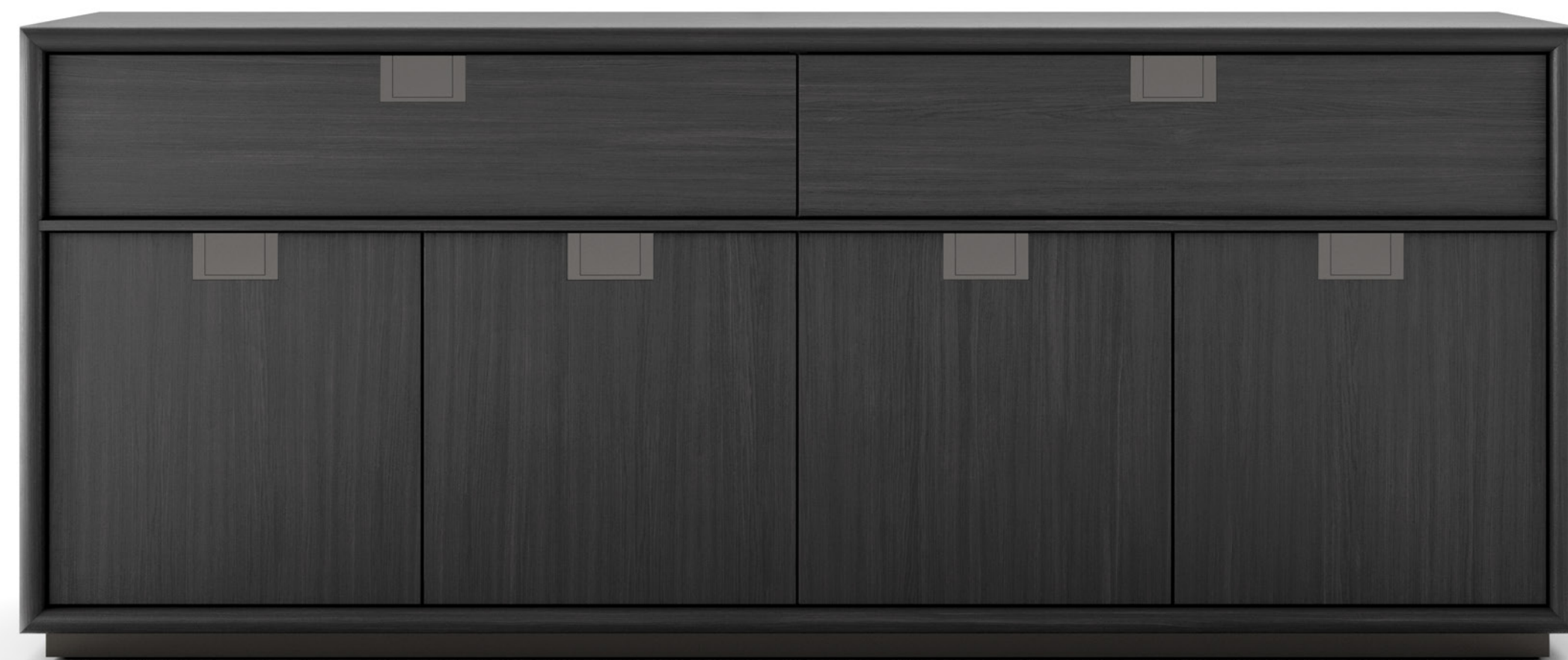

180 x 48 x h. 73,5 cm
70 7/8" x 18 7/8" x h. 28 7/8"



242 x 48 x h. 49 cm
95 1/4" x 18 7/8" x h. 19 1/4"

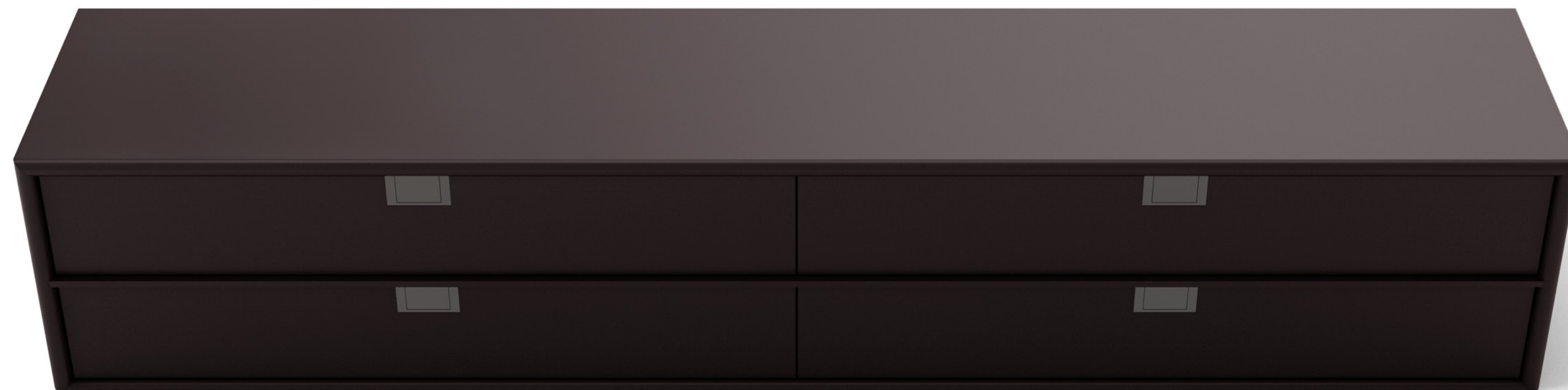

242 x 48 x h. 49 cm
95 1/4" x 18 7/8" x h. 19 1/4"

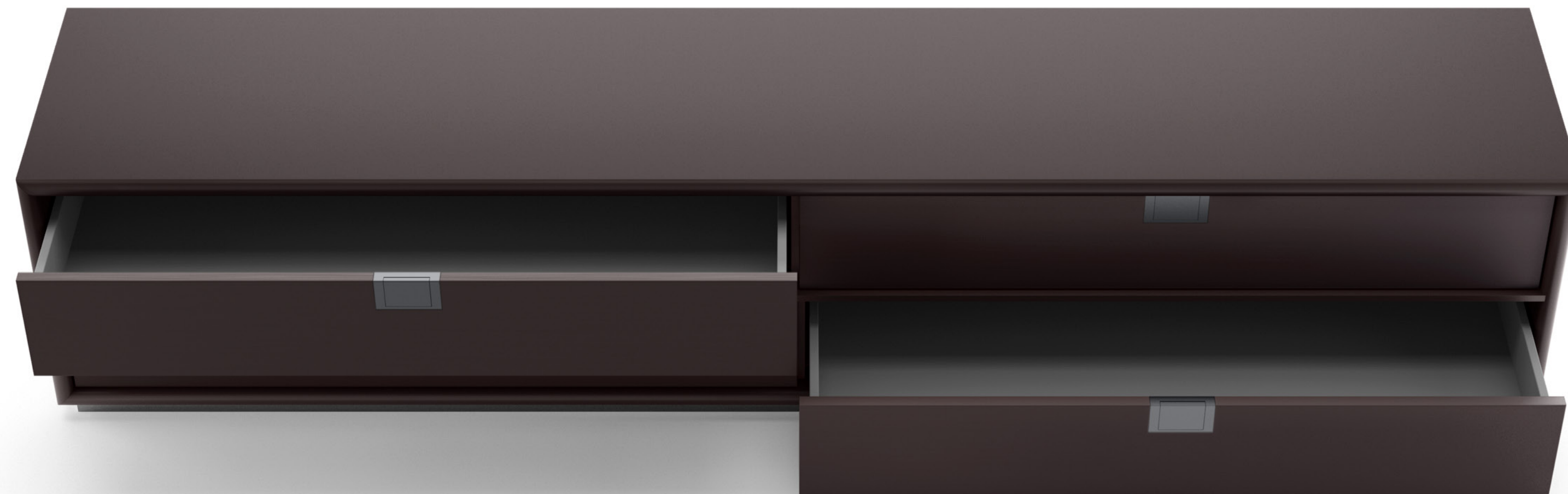

242 x 48 x h. 49 cm
95 1/4" x 18 7/8" x h. 19 1/4"



124 x 48 x h. 117 cm
48 7/8" x 18 7/8" x h. 46"



Technical details

STORAGE UNITS

NEW FLOOR-STANDING VERSION OF EXISTING ELEMENTS

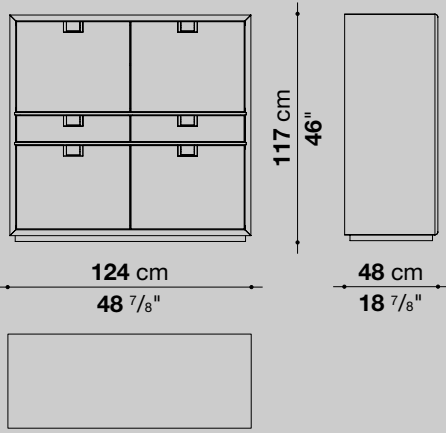

CTA120_3B

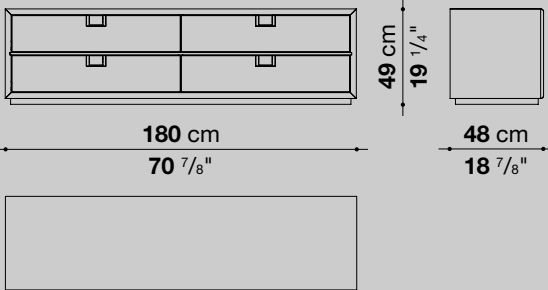

CSA180_2B

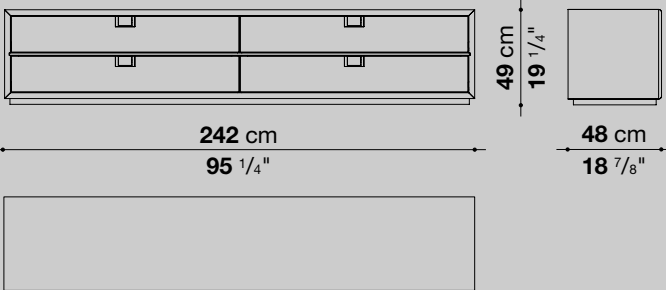

CSA240_2B

NEW ELEMENT TYPOLOGIES

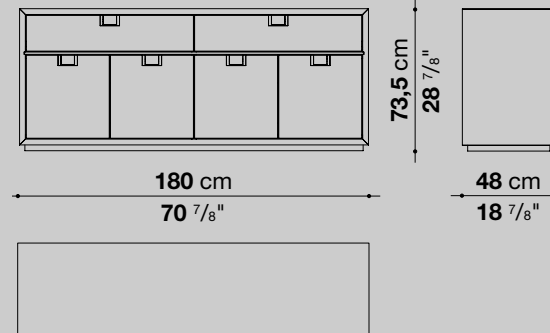

CTA180_2B

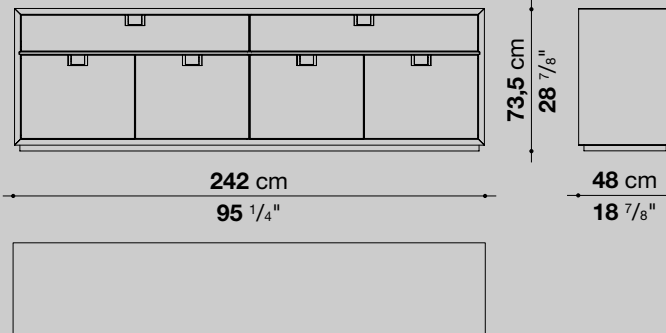

CTA240_1B

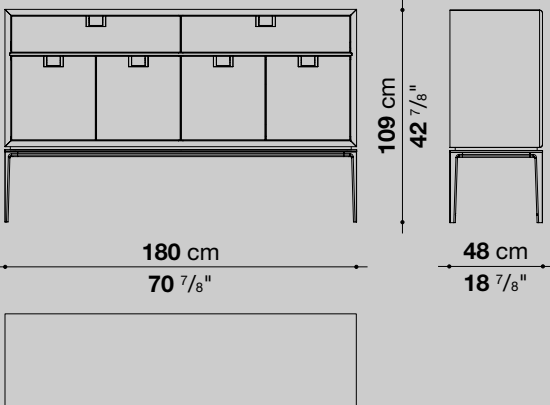

CTA180_2

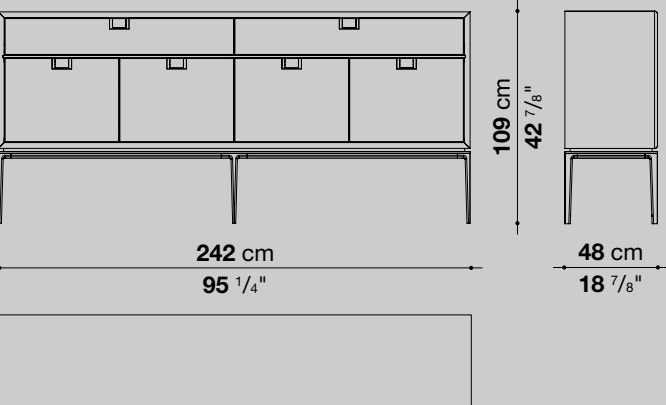

CTA240_1

Finishes

External and internal frame + shelf and extractable tray



0378G
GREY OAK



0374C
BRUSHED
LIGHT OAK

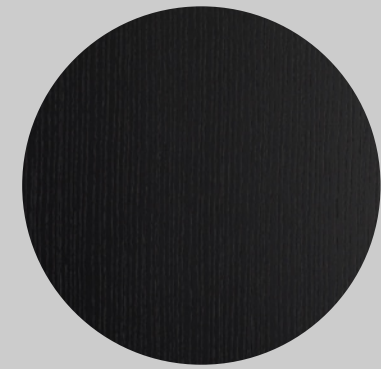

0381N
BRUSHED
BLACK OAK



0354B
WHITE ROUGH
CUT OAK

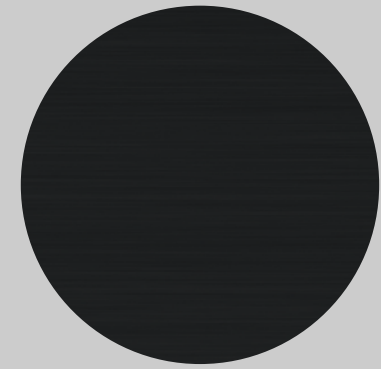

3764G
SHELLAC TYPE
FINISH BLACK

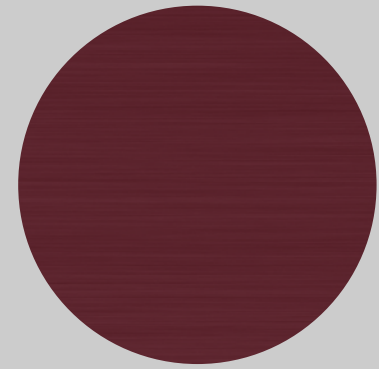

7110G
SHELLAC TYPE
FINISH RED

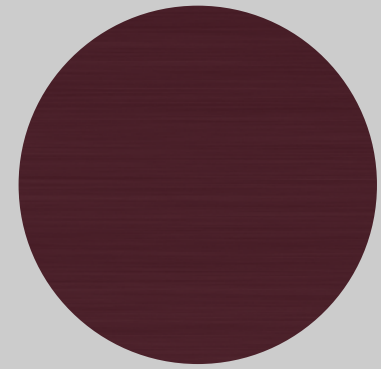

6805G
SHELLAC TYPE
FINISH SOYA

Cutlery holder

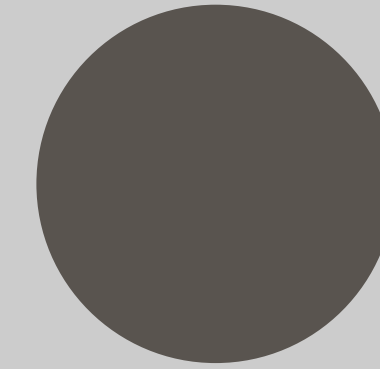

0169B
BRONZE NICKEL
PAINTED BEECH

Support frame

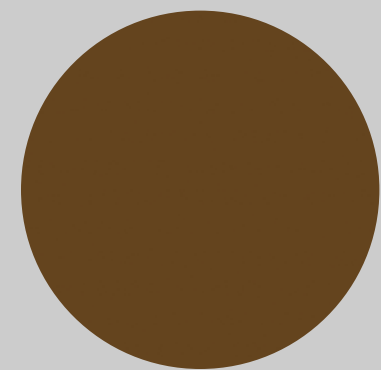

0137A
AMBER PAINTED

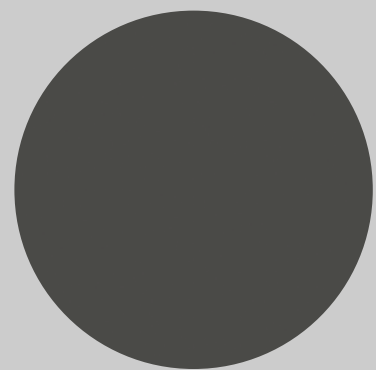

0252G
GRAPHITE
PAINTED

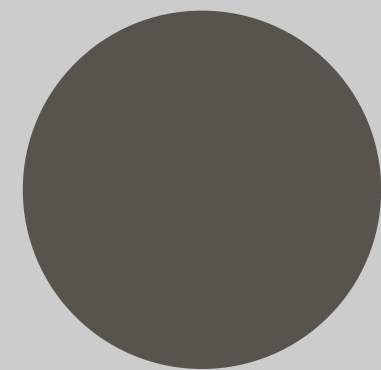

0174B
BRONZED
NICKEL PAINTED

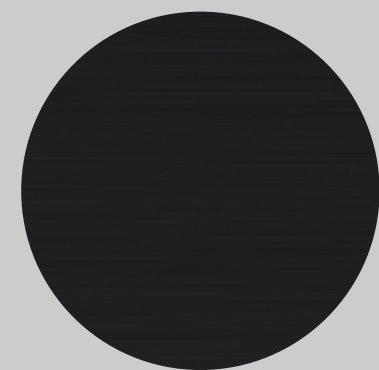

3764G
SHELLAC TYPE
FINISH BLACK

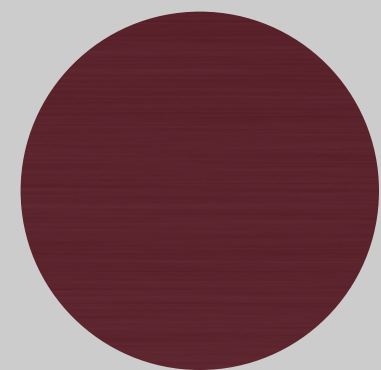

7110G
SHELLAC TYPE
FINISH RED

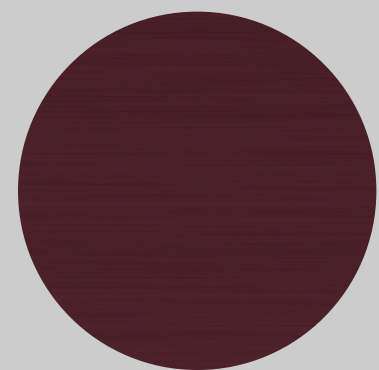

6805G
SHELLAC TYPE
FINISH SOYA

Handle

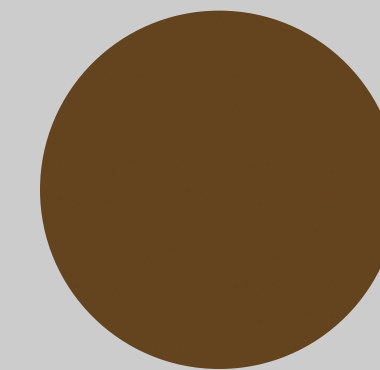

0137A
AMBER PAINTED

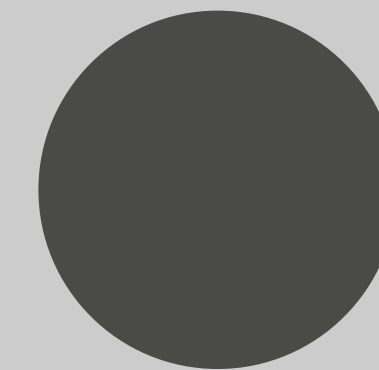

0252G
GRAPHITE
PAINTED

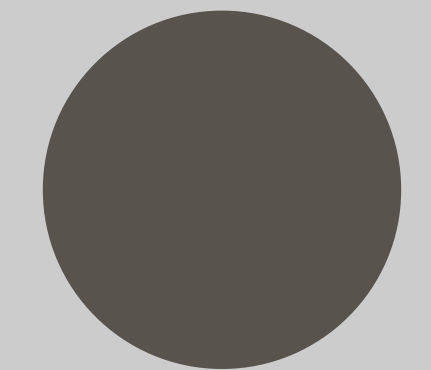

0174B
BRONZED
NICKEL PAINTED

Ares

Ares

To the existing design, Maxalto now introduces a new range extension, conceived to broaden the family with versions that express the same aesthetic identity through renewed proportions and more essential geometries. The bold structural presence of solid wood, with X-shaped legs created by the intersection of two overlapping profiles, is the defining feature of the Ares table, a piece that combines formal elegance with structural solidity.

Ares, from the Greek *Arēs*, recalls the idea of an original and concentrated force: primary energy that supports the form and guarantees its balance over time.



300 x 110 x h. 73 cm
118 1/8" x 43 1/4" x h. 28 3/4"



350 x 110 x h. 73 cm
137 3/4" x 43 1/4" x h. 28 3/4"



300 x 110 x h. 73 cm
118 1/8" x 43 1/4" x h. 28 3/4"

Ares

The tops of the new tables, offered in lengths of 300 cm and 350 cm, feature clean, lenticular lines and are paired with a wooden base that recalls the distinctive “false cross” of the original model, reinterpreted with an even purer language. The top can be finished to match the solid oak or wengé base, or alternatively in marble, for a more precious and materially expressive version.

The top is available in the new polished veined Arabescato marble finish, in addition to the polished white Calacatta and matt or polished black Marquinia marbles already present in the Maxalto collection, enhancing the table’s sculptural presence. This material choice accentuates the profile of the top and underscores the dialogue between the solidity of wood and the luminosity of marble, giving the Ares collection a renewed richness of interpretation.

With these new variants, Ares opens up to a wider range of interior scenarios, maintaining the iconic strength of its structure and reinforcing its role as a central element in the contemporary living space.

Technical details

TABLES

WOODEN VERSION

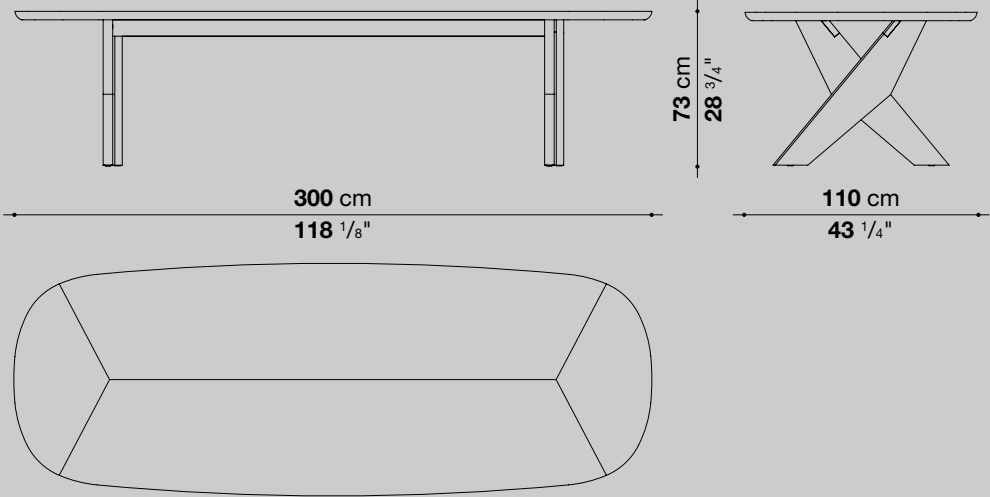

8 SEATS

TAR30

MARBLE TOP+WOODEN LEG VERSION

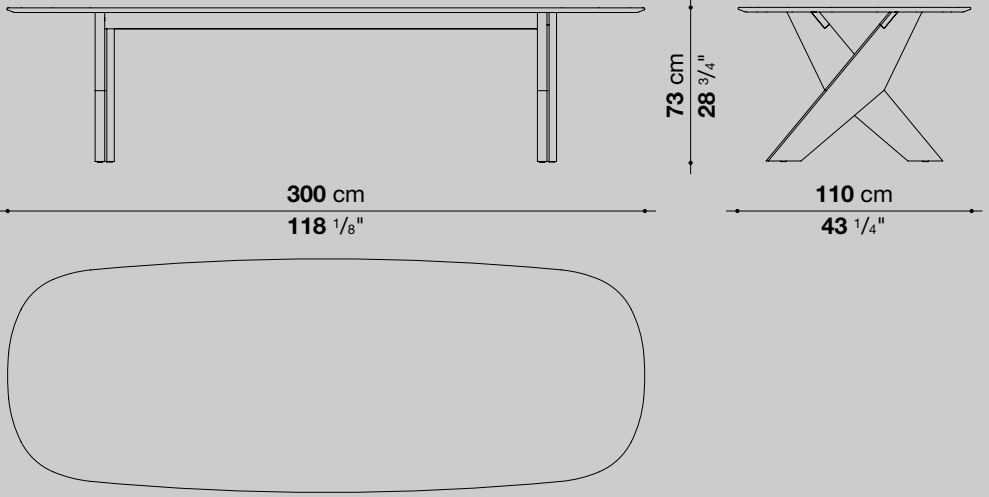

TAR30M

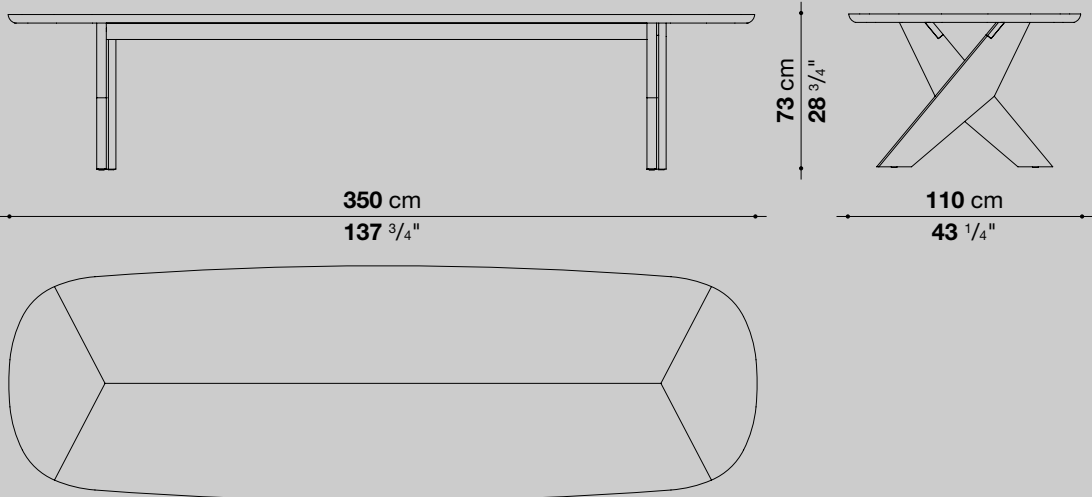

10 SEATS

TAR35

Finishes

Top



0378G
GREY OAK



0374C
BRUSHED
LIGHT OAK

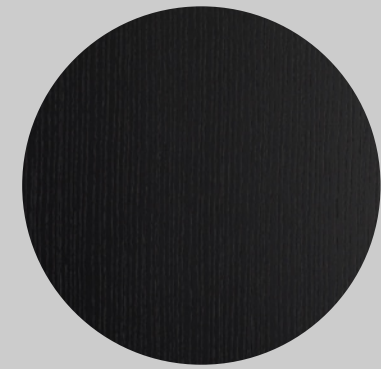

0381N
BRUSHED
BLACK OAK



0414W
NATURAL
WENGE



0839A
GLOSSY VEINED
ARABESCATO
MARBLE



0184P
GLOSSY
CALACATTA
WHITE MARBLE

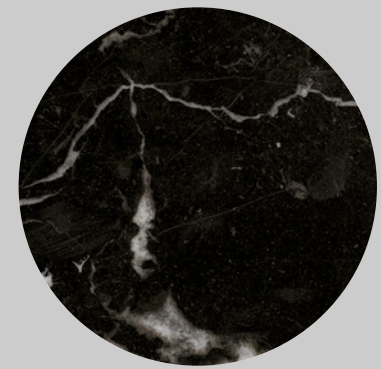

0185P - 0955M
GLOSSY - MATT
MARQUINIA
BLACK MARBLE

Frame



0378G
GREY OAK



0374C
BRUSHED
LIGHT OAK

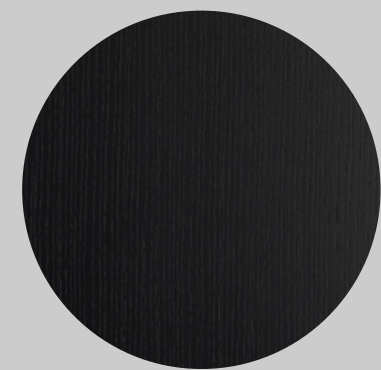

0381N
BRUSHED
BLACK OAK



0414W
NATURAL
WENGE

NOTE: TABLES CM 350 NOT AVAILABLE IN MARBLE AND NATURAL WENGE VERSION

MAXALTO RETAIL IDENTITY AND LAYOUT PROPOSALS

MAXALTO RETAIL IDENTITY







Logos



Backlights



Styling



Flooring



Boiserie/Walls



Freestanding boiserie screen



Canvas

LAYOUT PROPOSALS

Room 1

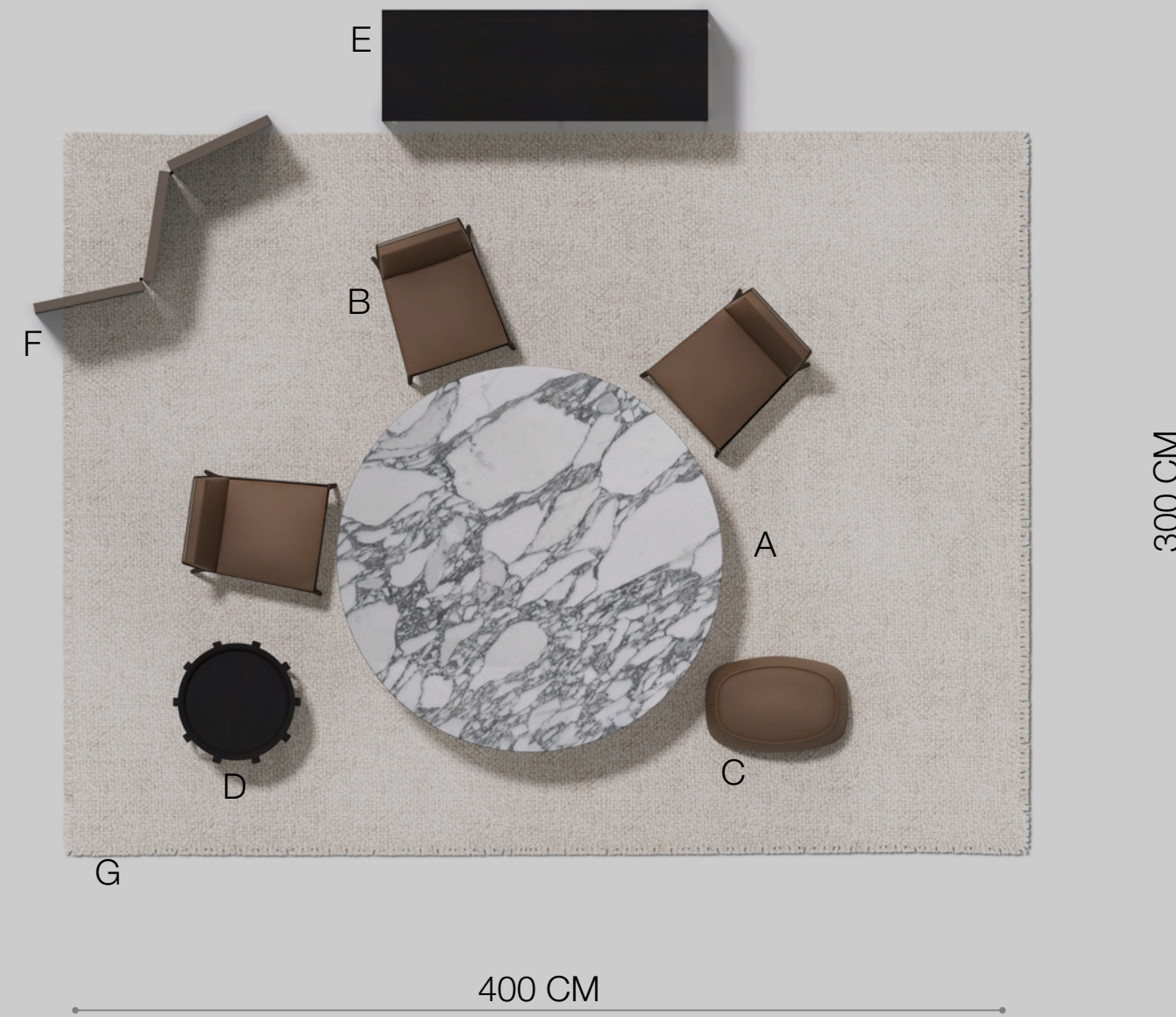

PROD.	N.	CODE	DESCRIPTION	FINISHING
A	1	TKL160_M	Kalystrus round table	Glossy veined arabescato marble 0839A
B	3	CA47N	Caratos chair	Kasia 1227330, bronzed nickel painted 0174B
C	1	IV59P	Intervallum ottoman	Kasia 1227330
D	1	SM53T	Loto small table	Black shellac type finish 3764G
E	1	LX01	Alcor storage unit with 3 hinged doors, 6 drawers and open compartments	Black shellac type finish 3764G
F	1	PV_3	Privatus windscreen (3 elements)	Light colour raffia 0651C
G	1	RS4T	Riso carpet 300x400	Light colour 0027C

Room 2

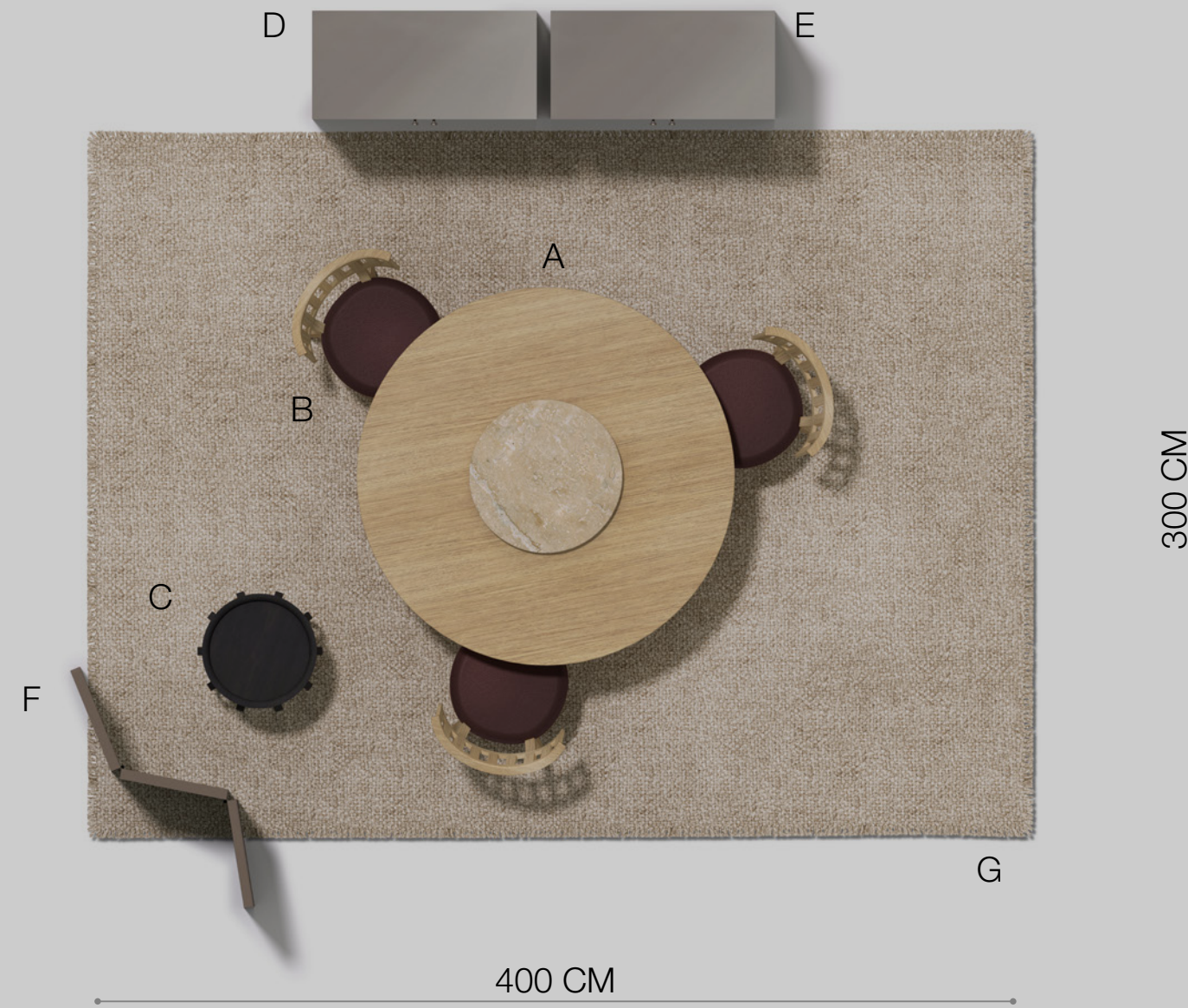

PROD.	N.	CODE	DESCRIPTION	FINISHING
A	1	TKL160G	Kalystrus round table	Brushed light oak 0374C
	1	TKL65V_M	Kalystrus swivel tray	Travertine marble with natural finish 0188P
B	3	CE55S	Cleide chair	Koto 1119350, brushed light oak 0374C
C	1	SM53T	Loto small table	Black shellac type finish 3764G
D	1	LMR6	Luminor storage unit with 2 hinged doors (internal equipment: shelves and extractable tray)	Yellow gold colour PVD 0652G, painted bronzed reflective glass 0124R, dove grey melamine faced 0815T, maple fris� 0351A"
E	1	LMR5	Luminor storage unit with 2 hinged doors (internal equipment: shelves)	Yellow gold colour PVD 0652G, painted bronzed reflective glass 0124R, dove grey melamine faced 0815T, maple fris� 0351A"
F	1	PV_3	Privatus windscreen (3 elements)	Light colour raffia 0651C
G	1	RS4T	Riso carpet 300x400	Soil colour 0071G

Room 3

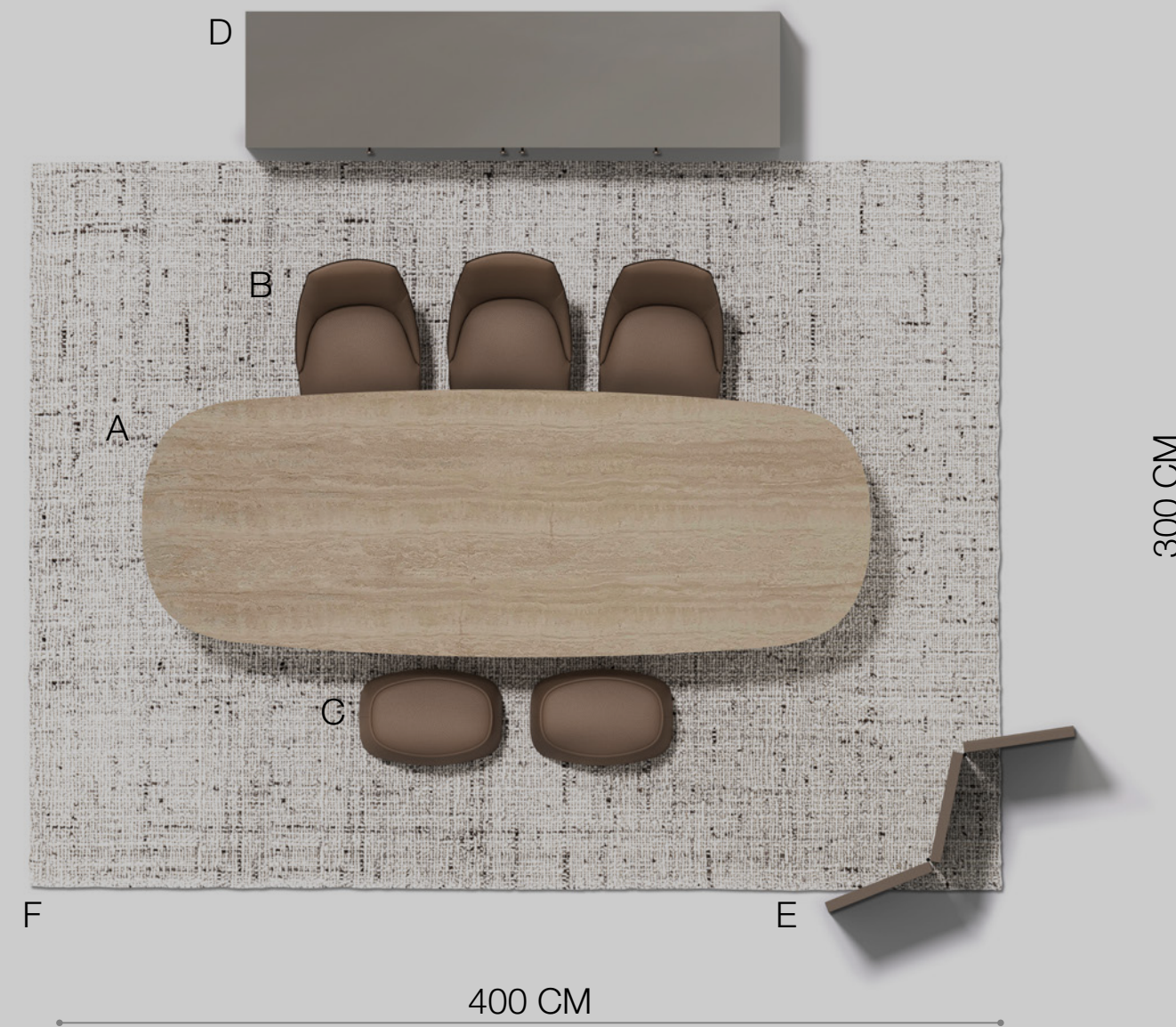

PROD.	N.	CODE	DESCRIPTION	FINISHING
A	1	TKL300_MR	Kalystrus rectangular table	Brushed light oak 0374C, travertine marble with natural finish 0188P
B	3	2808T	Febo chair	Kasia 1227330
C	2	IV59P	Intervallum ottoman	Kasia 1227330
D	1	LMR3	Luminor storage unit with 4 hinged doors (internal equipment: shelves)	Rose gold colour PVD 0504R, painted bronzed reflective glass 0124R, dove grey melamine faced 0815T, maple fris� 0351A
E	1	PV_3	Privatus windscreen (3 elements)	Light colour raffia 0651C
F	1	ML4T	Milos carpet 300x400	Quartz colour 0134Q

Room 4

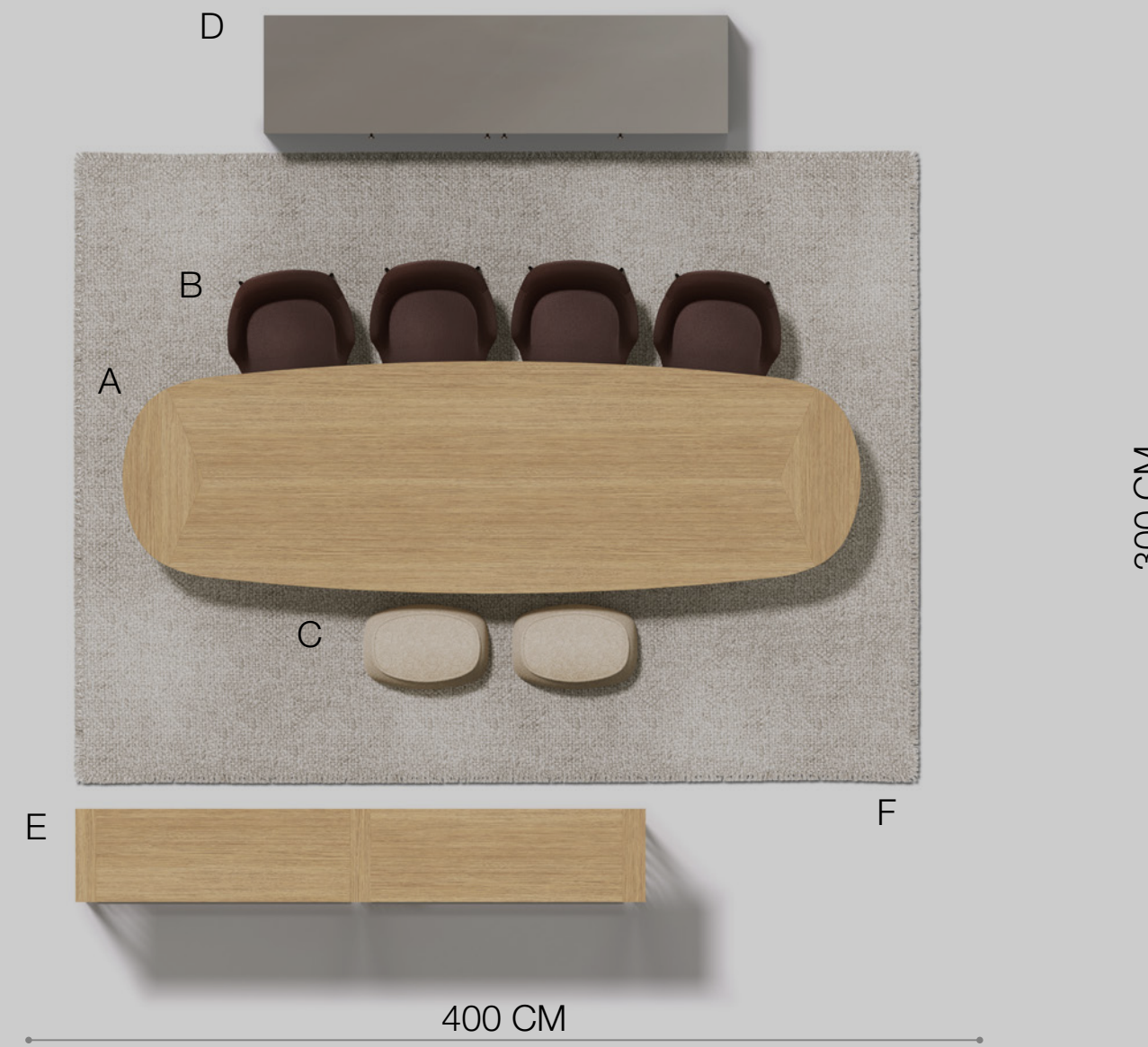

PROD.	N.	CODE	DESCRIPTION	FINISHING
A	1	TKL350	Kalystrus rectangular table	Brushed light oak 0374C
B	4	CA60A	Caratos chair with armrests	Koto 1119350, bronzed nickel painted 0174B
C	2	IV59P	Intervallum ottoman	Milo 2540200
D	1	LMR4	Luminor storage unit with 4 hinged doors (internal equipment: shelves, small drawer and extractable tray)	Rose gold colour PVD 0504R, painted bronzed reflective glass 0124R, dove grey melamine faced 0815T, maple fris� 0351A
E	2	2825	Biblia bookcase	Brushed light oak 0374C
F	1	RS4T	Riso carpet 300x400	Desert colour 0034D

Room 5

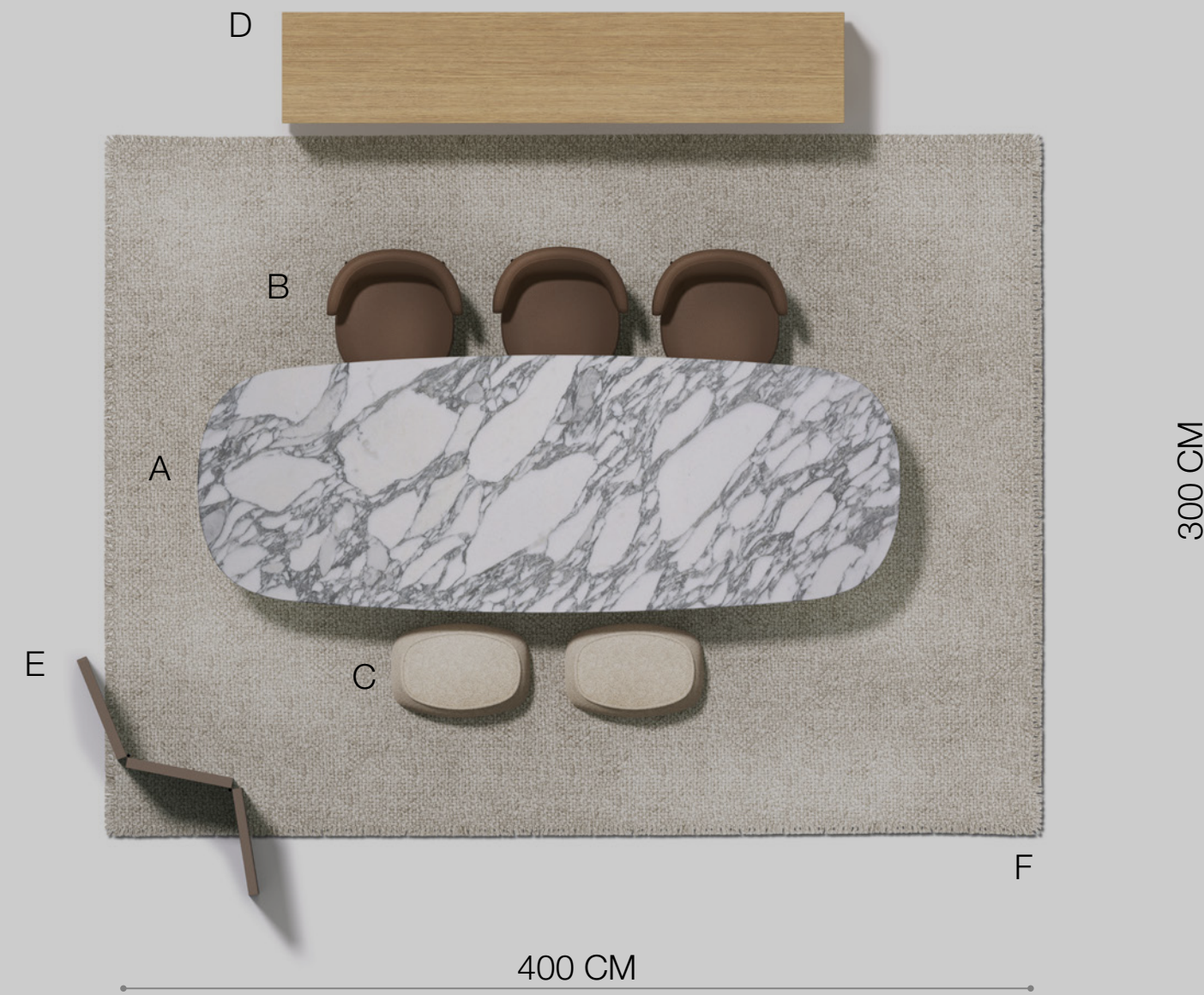

PROD.	N.	CODE	DESCRIPTION	FINISHING
A	1	TAR30	Ares rectangular table	Glossy veined arabescato marble 0839A, brushed light oak 0374C
B	3	SCA57A	Caratos chair	Kasia 1227330, bronzed nickel painted 0174B
C	2	IV59P	Intervallum ottoman	Milo 2540200
D	1	CTA240_1B	Artemone storage unit with 4 hinged doors and 2 drawers	Brushed light oak 0374C, bronzed nickel painted 0174B
	2	CTA_R12	Artemone internal shelf	Brushed light oak 0374C
E	1	PV_3	Privatus windscreen (3 elements)	Light colour raffia 0651C
F	1	RS4T	Riso carpet 300x400	Desert colour 0034D

MARKETING & COMMUNICATION

Delivery Terms

New products

LUMINOR

End of July

KALYSTRUS

End of April, wood - End of May, marble

Range extensions

ARTEMONE

27th April

ARES

27th April

Marketing & Communication

JANUARY 2026

FROM 15/01 Official release of the 2026 Maxalto News through corporate communication channels (website, Instagram, LinkedIn)
PR & Press office activity worldwide with a special focus on french media in january due to the Paris presentation

19/01 Paris Store setting photo shooting

FEBRUARY/MARCH 2026

Video-interview with Antonio Citterio

Lifestyle Shooting 2026

Ongoing release of the 2026 Maxalto News through corporate communication channels (website, Instagram, LinkedIn)
Starting of digital campaigns in Italy, US, France, and Germany.
New creativity that will last the whole year to support the brand presence in key strategic markets.

Renewal of the website products section (Caratos, Febo)

APRIL 2026

Launch of the new 2026 Maxalto living collection + Maxalto dining on display at Showroom via Durini 14, Milano
News 2026 Magazine

SECOND HALF 2026

New general catalogue
New digital projects (Behind the project - Camerae Act III)

YEARLY (APRIL – NOVEMBER 2026)

Media planning focusing on Key-countries

Paris, Maison & Objet

15 – 19 JANUARY 2026

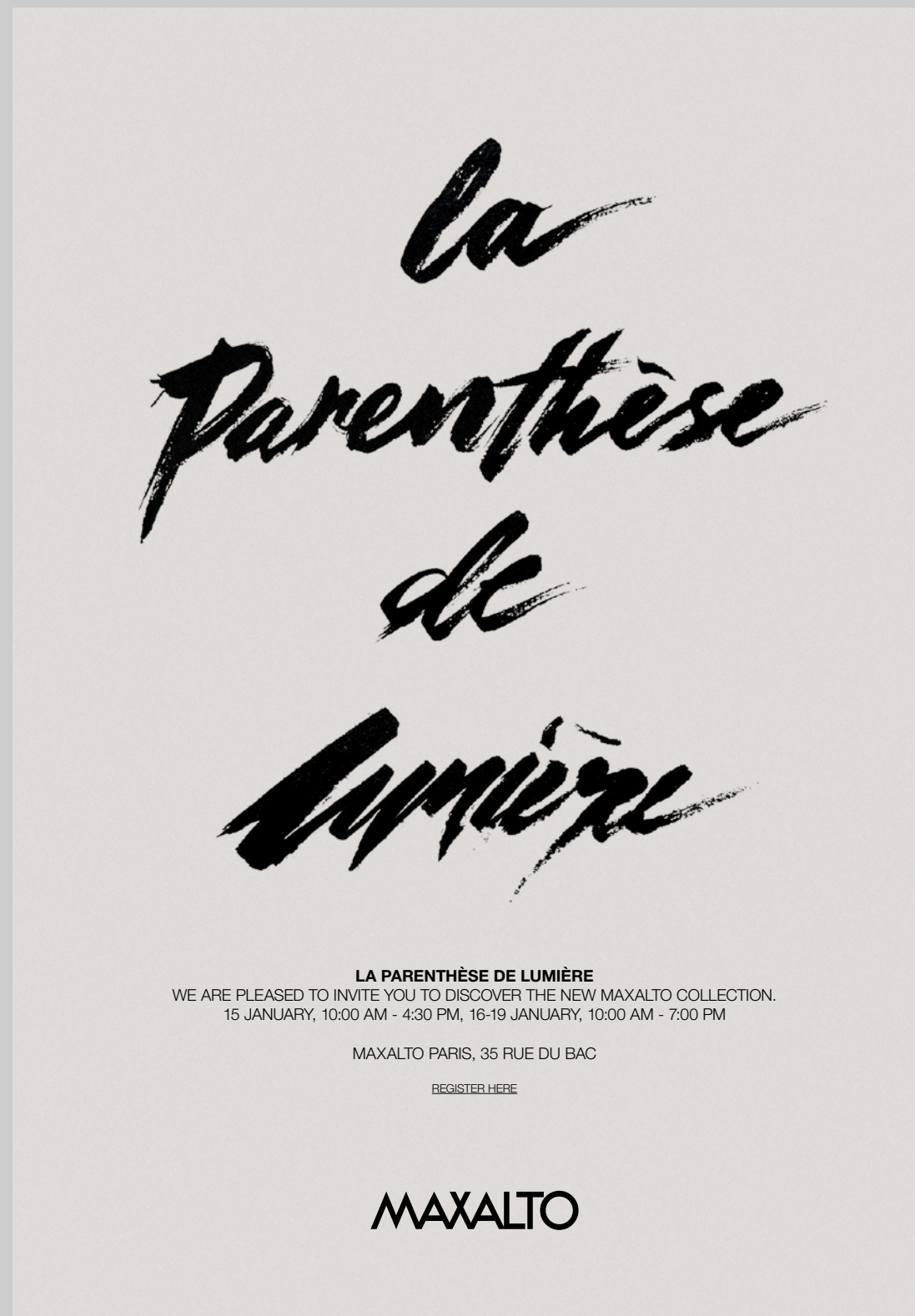

PRESS PREVIEW THURSDAY, 15 JANUARY, 9:30 AM - 4:30 PM
COCKTAIL PARTY THURSDAY, 15 JANUARY 6:00 PM - 9:00 PM

Paris, Maison & Objet

15 – 19 JANUARY 2026

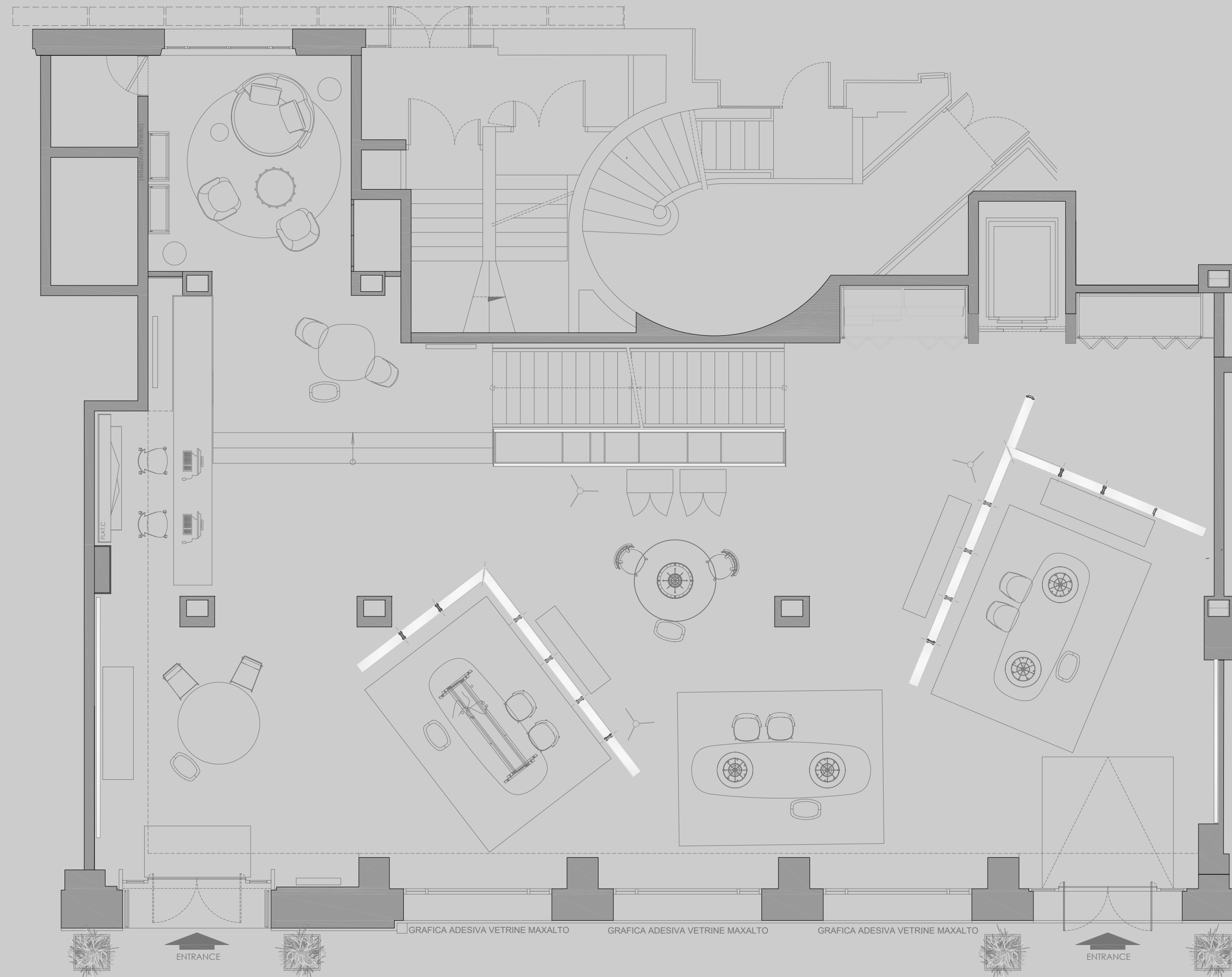

Paris, Maison & Objet

15 – 19 JANUARY 2026



Paris, Maison & Objet

15 – 19 JANUARY 2026



Paris, Maison & Objet

15 – 19 JANUARY 2026



Paris, Maison & Objet

15 – 19 JANUARY 2026



Paris, Maison & Objet

15 – 19 JANUARY 2026



Paris, Maison & Objet

15 – 19 JANUARY 2026



THANK YOU